

- 8 - 10 **SERIE MIZAR 30 - 60 - 60 VOX SERIES**  
ELETTROPOMPE SOMMERGIBILI PER ACQUE CHIARE E SPORCHE  
*SUBMERSIBLE ELECTRIC PUMPS FOR WHITE AND DIRTY WATER DRAINAGE*
- 11 **SERIE VERTICAL 30 - 60 SERIES**  
ELETTROPOMPE SOMMERGIBILI PER ACQUE CHIARE E SPORCHE CON GALLEGGIANTE VERTICALE  
*SUBMERSIBLE ELECTRIC PUMPS FOR WHITE AND DIRTY WATER DRAINAGE WITH VERTICAL FLOATER*
- 12 **SERIE LOWER 30 - 60 SERIES**  
ELETTROPOMPE SOMMERGIBILI PER ACQUE CHIARE CON ASPIRAZIONE RIBASSATA 2 MM  
*SUBMERSIBLE ELECTRIC PUMPS FOR WHITE AND DIRTY WATER DRAINAGE WITH 2 MM LOWERED ASPIRATION*
- 14 - 17 **SERIE MIZAR 30/S - 60/S - 60/S VOX Aisi 316 SERIES**  
ELETTROPOMPE SOMMERGIBILI DRENAGGIO PER ACQUE CHIARE, SPORCHE E LIQUIDI AGGRESSIVI  
*SUBMERSIBLE ELECTRIC PUMPS FOR WHITE, DIRTY WATERS AND AGGRESSIVE LIQUIDS DRAINAGE*
- 18 - 21 **SERIE REGAL "PROFESSIONAL" 80-100-150 - 100 VOX - 150 VOX 200 VOX SERIES **NEW****  
ELETTROPOMPE SOMMERGIBILI DRENAGGIO PER ACQUE SPORCHE E LEGGERMENTE SABBIOSE  
*SUBMERSIBLE ELECTRIC PUMPS FOR DIRTY AND LIGHTLY SANDY WATERS DRAINAGE*
- 22 - 25 **SERIE KONTRACT 180 - 250 SERIES**  
ELETTROPOMPE SOMMERGIBILI DRENAGGIO PER CANTIERISTICA  
*SUBMERSIBLE ELECTRIC PUMPS FOR CONSTRUCTION WORK SITE DRAINAGE*
- 26 - 29 **SERIE KONTRACT 300 - 400 - 600 SERIES**  
ELETTROPOMPE SOMMERGIBILI DRENAGGIO PER CANTIERISTICA  
*SUBMERSIBLE ELECTRIC PUMPS FOR CONSTRUCTION WORK SITE DRAINAGE*
- 30 - 33 **SERIE SPRING 30 - 60 - 80 - 100 - 150 SERIES**  
ELETTROPOMPE SOMMERGIBILI PER FONTANE E SVUOTAMENTO PISCINE  
*SUBMERSIBLE ELECTRIC PUMPS FOR FOUNTAINS AND SWIMMING POOL EMPTYING OPERATIONS*
- 34 - 37 **SERIE DUMPER 70 - 80 - 100 - 140 SERIES**  
ELETTROPOMPE SOMMERGIBILI DRENAGGIO PER ACQUE SPORCHE  
*SUBMERSIBLE ELECTRIC PUMPS FOR FOUL WASTEWATER DRAINAGE*

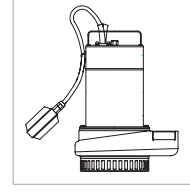
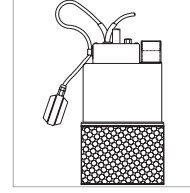
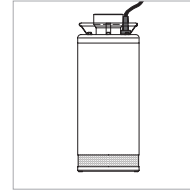
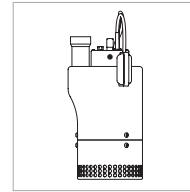
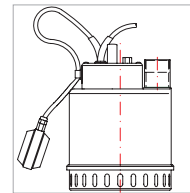
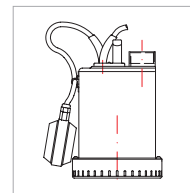
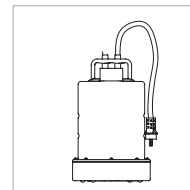
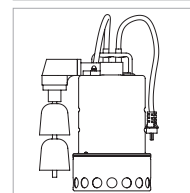
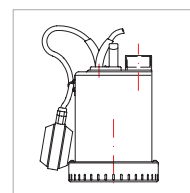

38 - 41

**SERIE DUMPER 150 - 200 - 300 SERIES**

ELETTROPOMPE SOMMERSIBILI DRENAGGIO PER ACQUE SPORCHE  
 SUBMERSIBLE ELECTRIC PUMPS FOR FOUL WASTEWATER DRAINAGE

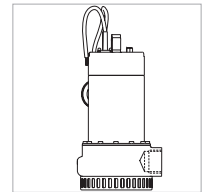

42 - 47

**SERIE TIGER 70 - 80 - 100 - 150 - 200 SERIES NEW**

ELETTROPOMPE SOMMERSIBILI VORTEX E BICANALI PER ACQUE CARICHE  
 SUBMERSIBLE VORTEX AND TWIN-CHANNEL IMPELLERS ELECTRIC PUMPS FOR WASTE WATER

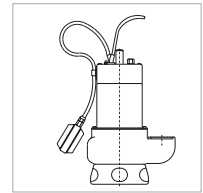

48 - 51

**SERIE TIGER 80F - 100F - 140F - 150F - 190F - 200F - 300F - 400F SERIES**

ELETTROPOMPE SOMMERSIBILI VORTEX PER ACQUE CARICHE, DOTATE DI CONTROFLANGIA  
 SUBMERSIBLE VORTEX ELECTRIC PUMPS FOR WASTE WATER, FEATURING A COUNTER FLANGE

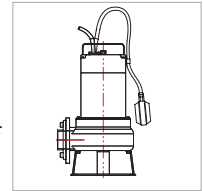

52 - 55

**SERIE SKIPPER 80F - 100F - 150F - 200F - 300F - 400F SERIES**

ELETTROPOMPE SOMMERSIBILI VORTEX PER ACQUE CARICHE,  
 DOTATE DI CONTROFLANGIA  
 SUBMERSIBLE VORTEX ELECTRIC PUMPS FOR WASTE WATER,  
 FEATURING A COUNTER FLANGE

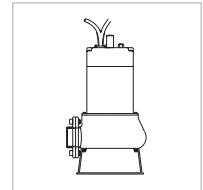

56 - 59

**SERIE SKIPPER 80 - 100 - 150 - 200 SERIES**

ELETTROPOMPE SOMMERSIBILI VORTEX PER ACQUE CARICHE  
 SUBMERSIBLE VORTEX ELECTRIC PUMPS FOR WASTEWATER

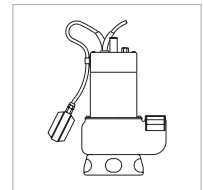

60 - 65

**SERIE ARVEX 80/S - 100/S - 150/S - 200/S BC Aisi 316 SERIES**

ELETTROPOMPE SOMMERSIBILI VORTEX E BICANALI PER ACQUE CARICHE  
 E LIQUIDI AGGRESSIVI  
 SUBMERSIBLE VORTEX AND TWIN-CHANNEL IMPELLERS ELECTRIC PUMPS  
 FOR WASTEWATER AND AGGRESSIVE LIQUIDS

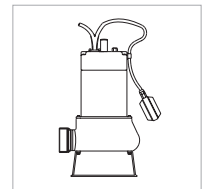

66 - 71

**SERIE ARVEX 80 - 100 - 150 - 200 Aisi 304 SERIES NEW**

ELETTROPOMPE SOMMERSIBILI VORTEX E BICANALI PER ACQUE CARICHE  
 SUBMERSIBLE VORTEX AND TWIN-CHANNEL IMPELLERS ELECTRIC PUMPS  
 FOR WASTEWATER

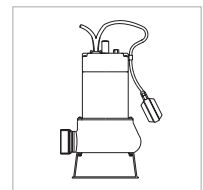

72 - 75

**SERIE RIVER 150F - 200F - 300F - 400F - 600F SERIES**

ELETTROPOMPE SOMMERSIBILI MONOCANALI PER ACQUE CARICHE,  
 DOTATE DI CONTROFLANGIA  
 SUBMERSIBLE SINGLE CHANNEL ELECTRIC PUMPS FOR VERY FOUL WASTE  
 WATER, FEATURING A COUNTER FLANGE

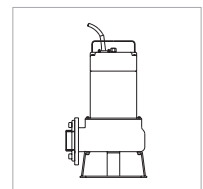

76 - 79

**SERIE TENAX 150F - 200F - 300F - 400F - 600F SERIES**

ELETTROPOMPE SOMMERSIBILI MONOCANALI PER ACQUE CARICHE  
 DOTATE DI CONTROFLANGIA  
 SUBMERSIBLE SINGLE CHANNEL ELECTRIC PUMPS FOR VERY FOUL WASTE  
 WATER, FEATURING A COUNTER FLANGE

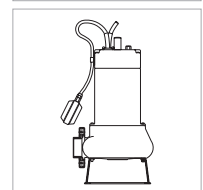

80 - 83

**SERIE CUTTER 140 - 150 - 200 - 300 SERIES**

ELETTROPOMPE SOMMERSIBILI TRITURATRICI PER ACQUE SPORCHE E CARICHE  
 GRINDER SUBMERSIBLE ELECTRIC PUMPS FOR FOUL AND HEAVY WASTE WATER

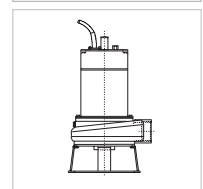

84 - 87

**SERIE ROXI 75 SERIES** 

ELETTROPOMPE SOMMERGIBILI MULTISTADIO  
VERTICAL SUBMERSIBLE SINGLE-BLOCK MULTISTAGE ELECTRIC PUMPS

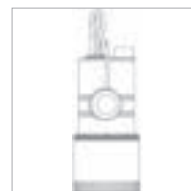

88 - 91

**SERIE GPV.RX 100 - 150 - 200 SERIES**

ELETTROPOMPE SOMMERGIBILI MONOBLOCCO MULTISTADIO VERTICALI  
PER POZZI DA 6 POLLICI  
VERTICAL SUBMERSIBLE SINGLE BLOCK MULTISTAGE ELECTRIC PUMPS  
FOR 6 INCH WELLS

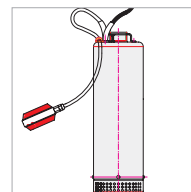

92 - 95

**SERIE WORKER 150 - 250 SERIES**

ELETTROPOMPE SOMMERGIBILI MONOBLOCCO MULTISTADIO VERTICALI  
PER POZZI DA 8 E 10 POLLICI  
VERTICAL SUBMERSIBLE SINGLE BLOCK MULTISTAGE ELECTRIC PUMPS  
FOR 8 AND 10 INCH WELLS

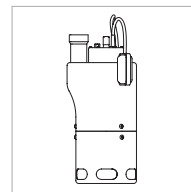

96 - 99

**SERIE WORKER 300 - 400 - 500 - 750 - 1000 SERIES**

ELETTROPOMPE SOMMERGIBILI MONOBLOCCO MULTISTADIO VERTICALI  
PER POZZI DA 8 E 10 POLLICI  
VERTICAL SUBMERSIBLE SINGLE BLOCK MULTISTAGE ELECTRIC PUMPS  
FOR 8 AND 10 INCH WELLS

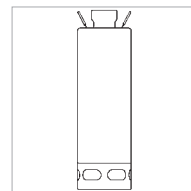

100 - 101

**SISTEMI DI DISCESA (DN 50 - DN 80) PER IMPIANTI FISSI**  
**GUIDE RAIL SYSTEMS (DN50 - DN80) FOR FIXED PLANTS**

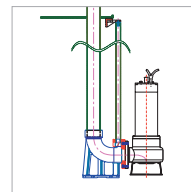

102 - 103

**SERIE BOX - 1 / SERIE BOX - 2**

STAZIONI AUTOMATICHE PER LA RACCOLTA E IL SOLLEVAMENTO DI ACQUE CARICHE  
AUTOMATIC STATIONS FOR COLLECTING AND LIFTING WASTE WATER

POMPE SOMMERGIBILI IN GHISA - SUBMERSIBLE PUMPS IN CAST IRON

104 - 107

**SERIE TURBO 200 - 250 SERIES**

ELETTROPOMPE SOMMERGIBILI MONOBLOCCO MULTISTADIO VERTICALI  
VERTICAL SUBMERSIBLE MULTI-STAGE ELECTRIC PUMPS



108 - 111

**SERIE TURBO 300 - 400 - 500 SERIES**

ELETTROPOMPE SOMMERGIBILI MONOBLOCCO MULTISTADIO VERTICALI  
VERTICAL SUBMERSIBLE MULTI-STAGE ELECTRIC PUMPS



112 - 115

**SERIE TURBO 750 - 1000 SERIES**

ELETTROPOMPE SOMMERGIBILI MONOBLOCCO MULTISTADIO VERTICALI  
VERTICAL SUBMERSIBLE MULTI-STAGE ELECTRIC PUMPS





## POMPE SOMMERGIBILI IN GHISA SUBMERSIBLE PUMPS IN CAST IRON

116 - 119 **SERIE TURBO-L 200 SERIES**  
ELETTROPOMPE SOMMERGIBILI DRENAGGIO PER ACQUE SPORCHE E LEGGERMENTE SABBIOSE  
*SUBMERSIBLE ELECTRIC PUMPS FOR LIGHTLY SANDY FOUL WASTEWATER DRAINAGE*



120 - 123 **SERIE TURBO-LG 250 - 350 SERIES** **NEW**  
ELETTROPOMPE SOMMERGIBILI DRENAGGIO PER CANTIERISTICA  
*SUBMERSIBLE ELECTRIC PUMPS FOR COSTRUCTION WORK SITE DRAINAGE*

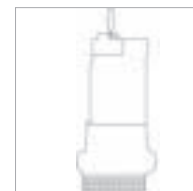

124 - 127 **SERIE TURBO-LG 500 - 550 - 750 - 1000 SERIES**  
ELETTROPOMPE SOMMERGIBILI DRENAGGIO PER CANTIERISTICA  
*SUBMERSIBLE ELECTRIC PUMPS FOR COSTRUCTION WORK SITE DRAINAGE*



128 - 131 **SERIE TURBO-TC 200 - 300 SERIES** **NEW**  
ELETTROPOMPE SOMMERGIBILI BICANALI PER ACQUE CARICHE  
*SUBMERSIBLE TWIN CHANNEL ELECTRIC PUMPS FOR WASTEWATER*

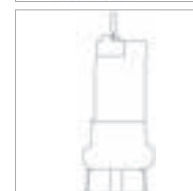

## POMPE SOMMERGIBILI IN PLASTICA - PLASTIC SUBMERSIBLE PUMPS

132 **SERIE NCC 24 SERIES**  
POMPE SOMMERGIBILI IN PLASTICA 24 VOLT (**DRENAGGIO**)  
*PLASTIC SUBMERSIBLE PUMPS 24 VOLT (DRAINAGE)*

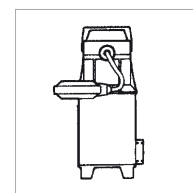

133 **SERIE NCC 24T SERIES**  
POMPE SOMMERGIBILI IN PLASTICA 24 VOLT (**VORTEX**)  
*PLASTIC SUBMERSIBLE PUMPS 24 VOLT (VORTEX)*

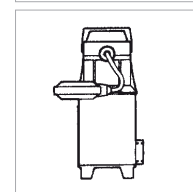

134 - 135 **SERIE SPA E SPM SERIES**  
POMPE SOMMERGIBILI PER ACQUE CHIARE E SPORCHE  
*SUBMERSIBLE PUMPS FOR WHITE AND DIRTY WATER*

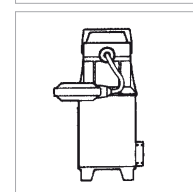

136 **SERIE MAXIMA SERIES**  
POMPE SOMMERGIBILI PER ACQUE SPORCHE (**VORTEX**)  
*SUBMERSIBLE PUMPS FOR DIRTY WATER (VORTEX)*

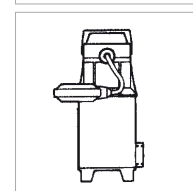

## MOTORI SOMMERSI - SUBMERSIBLE MOTORS

137 **SERIE OPM SERIES**  
MOTORE SOMMERSO 4"  
*SUBMERSIBLE MOTOR 4"*

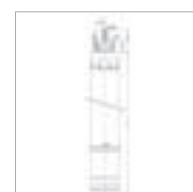

- 138 - 141 **SERIE AP SERIES**  
ELETTROPOMPE SOMMERSE PER POZZI DA 4" INTERAMENTE IN ACCIAIO INOX  
SUBMERSIBLE ELECTRIC PUMPS, FOR 4 INCH WELLS FULLY IN STAINLESS STEEL

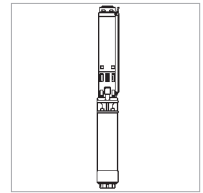

- 142 - 149 **SERIE ST**  
ELETTROPOMPE SOMMERSE PER POZZI DA 4"  
SUBMERSIBLE ELECTRIC PUMPS, FOR 4 INCH WELLS

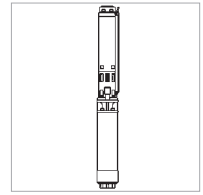

## POMPE DI SUPERFICIE - SURFACE PUMPS

- 150 - 153 **SERIE PMF 50 - 100 - 150 - 200 SERIES**  
ELETTROPOMPE PERIFERICHE  
PERIPHERAL ELECTRIC PUMPS

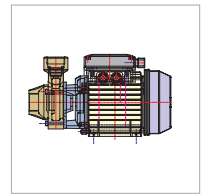

- 154 - 157 **SERIE JET 90 - 100 - 150 - 200 SERIES**  
ELETTROPOMPE AUTOADESCANTI IN GHISA  
SELF PRIMING ELECTRIC PUMPS IN CAST IRON

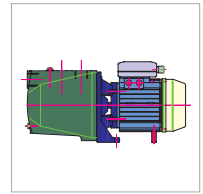

- 158 - 161 **SERIE JETX 90 - 100 SERIES**  
ELETTROPOMPE AUTOADESCANTI **Aisi 304**  
SELF PRIMING ELECTRIC PUMPS **Aisi 304**

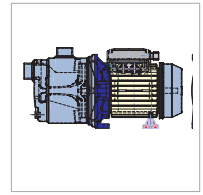

- 162 - 165 **SERIE R 50 - 75 - 100 - 150 - 200 - 300 SERIES**  
ELETTROPOMPE CENTRIFUGHE, MONOGIRANTI  
CENTRIFUGAL ELECTRIC PUMPS, SINGLE-IMPELLERS

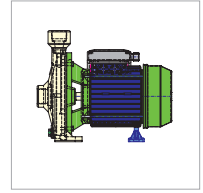

- 166 - 169 **SERIE RB 100 - 150 - 200 - 300 - 400 - 550 - 750 SERIES**  
ELETTROPOMPE CENTRIFUGHE, BIGIRANTI  
CENTRIFUGAL ELECTRIC PUMPS, DOUBLE IMPELLERS

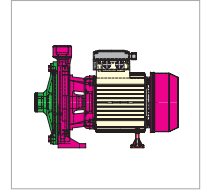

- 170 - 173 **SERIE RPG 75 - 100 SERIES**  
ELETTROPOMPE CENTRIFUGHE MULTICELLULARI IN GHISA  
CENTRIFUGAL MULTISTAGE ELECTRIC CAST IRON PUMPS

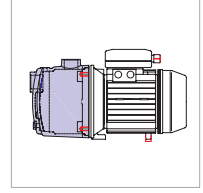

- 174 - 177 **SERIE RPX 90 - 130 SERIES**  
ELETTROPOMPE CENTRIFUGHE MULTICELLULARI **Aisi 304**  
MULTISTAGE CENTRIFUGAL ELECTRIC PUMPS **Aisi 304**

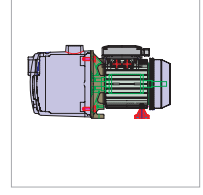

## POMPE DI SUPERFICIE - SURFACE PUMPS

178 - 181 **SERIE RM 80 - 100 - 150 SERIES**  
 ELETTROPOMPE CENTRIFUGHE MULTICELLULARI **AISI 304**  
 MULTISTAGE CENTRIFUGAL ELECTRIC PUMPS **AISI 304**



182 - 189 **SERIE CR 80 - 100 - 150 - 200 - 250 SERIES**  
 ELETTROPOMPE CENTRIFUGHE MONOBLOCCO  
 MONOBLOCK CENTRIFUGAL ELECTRIC PUMPS

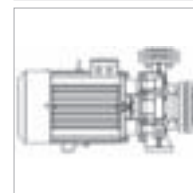

## GRUPPI DI PRESSURIZZAZIONE - PRESSURE SYSTEM

190 - 191 **SERIE PS 2-RB - PI 2-RB - PS 2-RM SERIES**  
 GRUPPI DI PRESSURIZZAZIONE  
 PRESSURE SYSTEM

## MOTOPOMPE - GASOLINE WATER PUMPS

192 - 195 **SERIE GMA 0225-0425-0430-0440 SERIES**  
 MOTOPOMPE AUTODESCANTI PORTATILI  
 SELFPRIMING HAND-CARRY GASOLINE PUMPS



## POMPE A MANO - HANDS PUMPS

196 - 197 **SERIE K 300 - 400 - 500 - 600 SERIES**  
 POMPE A MANO SEMI ROTATIVE  
 SEMI ROTATING HAND PUMPS

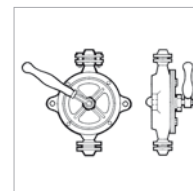

198 - 199 **SERIE NP 600 - 650 SERIES**  
 POMPE A MANO ASPIRANTI VERTICALI  
 HAND OPERATED VERTICAL SUCTION PUMPS

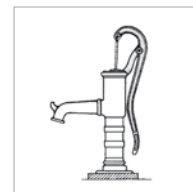

200 - 214 **ACCESSORI E TABELLE RESISTENZE CHIMICHE**  
**ACCESSORIES AND RESISTANCE CHEMICAL TABLES**

# MIZAR



## **ELETTROPOMPE SOMMERSIBILI DRENAGGIO PER ACQUE CHIARE E SPORCHE SUBMERSIBLE ELECTRIC PUMPS FOR WHITE AND DIRTY WATER DRAINAGE**

**PREVALENZA : 8,0 mt. ÷ 10,0 mt.**

**PORTATA : 9,0 m<sup>3</sup>/h ÷ 10,5 m<sup>3</sup>/h**

**POTENZA NOMINALE : 0,25 kW (0,33 HP) ÷ 0,45 kW (0,6 HP)**

**PASSAGGIO SOLIDI FINO A 10 mm (SERIE VOX 20 mm)**

**PUMP HEAD ..... : 8,0 mt ÷ 10,0 mt**

**DELIVERY ..... : 9,0 m<sup>3</sup>/h ÷ 10,5 m<sup>3</sup>/h**

**RATED HORSEPOWER : 0,25 kW (0,33 HP) ÷ 0,45 kW (0,6 HP)**

**SOLID MATTER BYPASS up to 10 mm (SERIE VOX 20 mm)**

### **APPLICAZIONI**

- SVUOTAMENTO DA ACQUE PIOVANE, D'INFILTRAZIONE, DI POZZETTI O VASCHE DI RACCOLTA.
- PRELIEVO DA VASCHE DI RACCOLTA DI ACQUE PIOVANE PER PICCOLE IRRIGAZIONI A SCORRIMENTO DI ORTI E DI GIARDINI.
- TRAVASO DI ACQUA CHIARA DA SERBATOI E VASCHE.
- POMPAGGIO DI ACQUE SPORCHE CON CORPI SOLIDI IN SOSPENSIONE (SOLO SERIE VOX).

### **APPLICATIONS**

- RAIN, SEEPAGE, SUMP PIT AND CATCH TANK WATER PUMP OUT.
- GARDEN AND VEGETABLE-GARDEN MINI FLOOD IRRIGATION SYSTEM RAINWATER CATCH TANK PUMP DOWN.
- WHITE WATER PUMP OVER FROM RESERVOIRS AND VATS.
- PUMPING DIRTY WATER WITH POSSIBLE FLOATING SOLID CONTENTS (ONLY VOX SERIES).

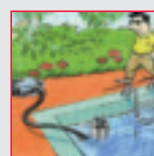
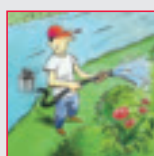

**AV ARVEN**

**CARATTERISTICHE DI COSTRUZIONE:**

- MOTORE A SECCO RAFFREDDATO DAL LIQUIDO POMPATO
- DOPPIA TENUTA MECCANICA: DOPPIO ANELLO DI TENUTA LATO MOTORE, TENUTA MECCANICA A BAGNO D'OLIO LATO POMPA
- IMMERSIONE MASSIMA: mt. 5.
- GRADO DI PROTEZIONE IP 68.
- CLASSE DI ISOLAMENTO: F
- TEMPERATURA MAX.LIQUIDO POMPATO: 35°C
- PASSAGGIO LIBERO: 10 mm MIZAR 30 - 60  
20mm MIZAR 60 VOX
- VERSIONI: Monofase: 220-277V/50Hz o 220-277V/60Hz con protettore termico incorporato e condensatore permanentemente inserito.
- CAVO STANDARD:  
Monofase: 10 metri H07RN-F per versione normale (aut.-man).  
5 metri H07RN-F solo per versione automatica.

SPECIALI VOLTAGGI E FREQUENZE A RICHIESTA.

**DESIGN ENGINEERING:**

- SEMI WET MOTOR WATERCOOLED
- DOUBLE MECHANICAL SEAL: DOUBLE SEAL RING -ENGINE FACE  
OIL BATH MECHANICAL SEALS PUMP FACE
- PERMISSIBLE DRAUGHT OF WATER: 5 m
- IP 68 PROTECTION CLASS.
- CLASS "F" INSULATION.
- MAX. PUMPED LIQUID TEMPERATURE: 35°C
- BY PASS SECTION: 10 mm MIZAR 30 - 60  
20mm MIZAR 60 VOX.
- VERSIONS: Single Phase: 220-277V/50Hz or 220-277V/60Hz with built in thermal protection and permanent capacitor.
- STANDARD CABLE FEATURES:  
Single phase :10 metres H07RN-F for the standard version (automatic-manual).  
5 metres H07RN-F only for the automatic version.

CUSTOMISED VOLTAGE AND FREQUENCY RATING AVAILABLE ON DEMAND.

**TABELLA MATERIALI - MATERIALS TABLE:**

Pos.	Componente - Component	Materiale - Materials
A	Carcassa esterna / External motor housing	ACCIAIO INOX AISI 304 - DIN 1.4301 / STAINLESS STEEL
B	Girante / Impeller	MIZAR 30 - 60 TECNOPOLIMERO TECNOPOLYMER
		MIZAR 60 VOX ACCIAIO INOX (AISI 304 - DIN 1.4305) / STAINLESS STEEL
C	Albero (lato pompa) / Shaft (pump side)	ACCIAIO INOX AISI 303 - DIN 1.4005 / STAINLESS STEEL
D	Tenuta meccanica / Mechanical seal	Lato pompa / Pump face GRAFITE-CERAMICA GRAPHITE - CERAMIC
		Lato motore / Motor face DOPPIO ANELLO DI TENUTA NBR NBR DOUBLE SEALING RING
E	O-ring	NBR
F	Porta tenuta / Seal holder	ACCIAIO INOX AISI 304 - DIN 1.4301 / STAINLESS STEEL
G	Porta motore / Motor holder	TECNOPOLIMERO TECNOPOLYMER
H	Cassa motore / Motor housing	ACCIAIO INOX AISI 304 - DIN 1.4301 / STAINLESS STEEL
I	Coperchio / Cover	TECNOPOLIMERO TECNOPOLYMER
L	Diffusore / Diffuser	ACCIAIO INOX AISI 304 - DIN 1.4301 STAINLESS STEEL
N	Base d'aspirazione / Suction base	

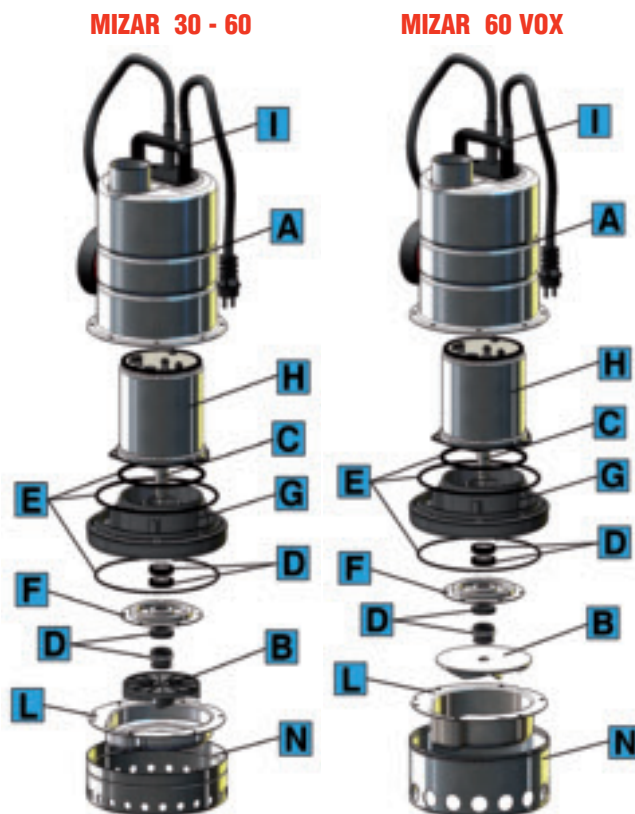

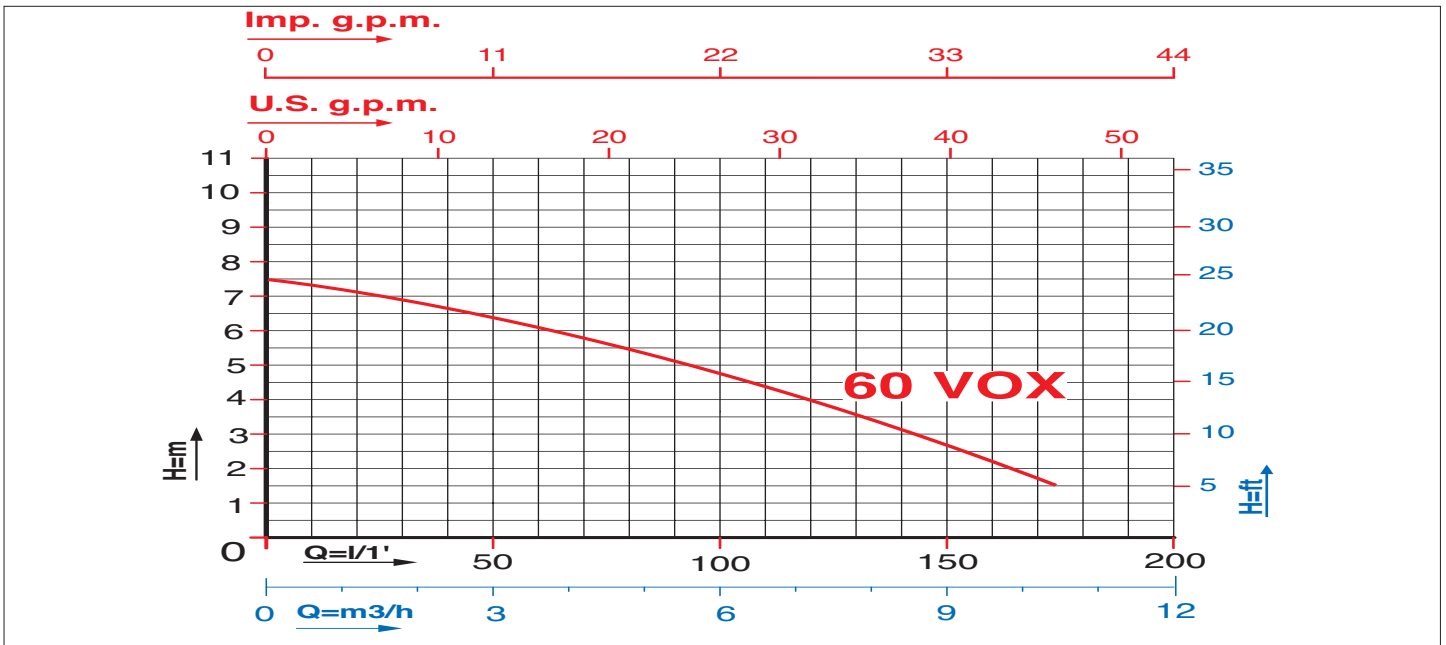
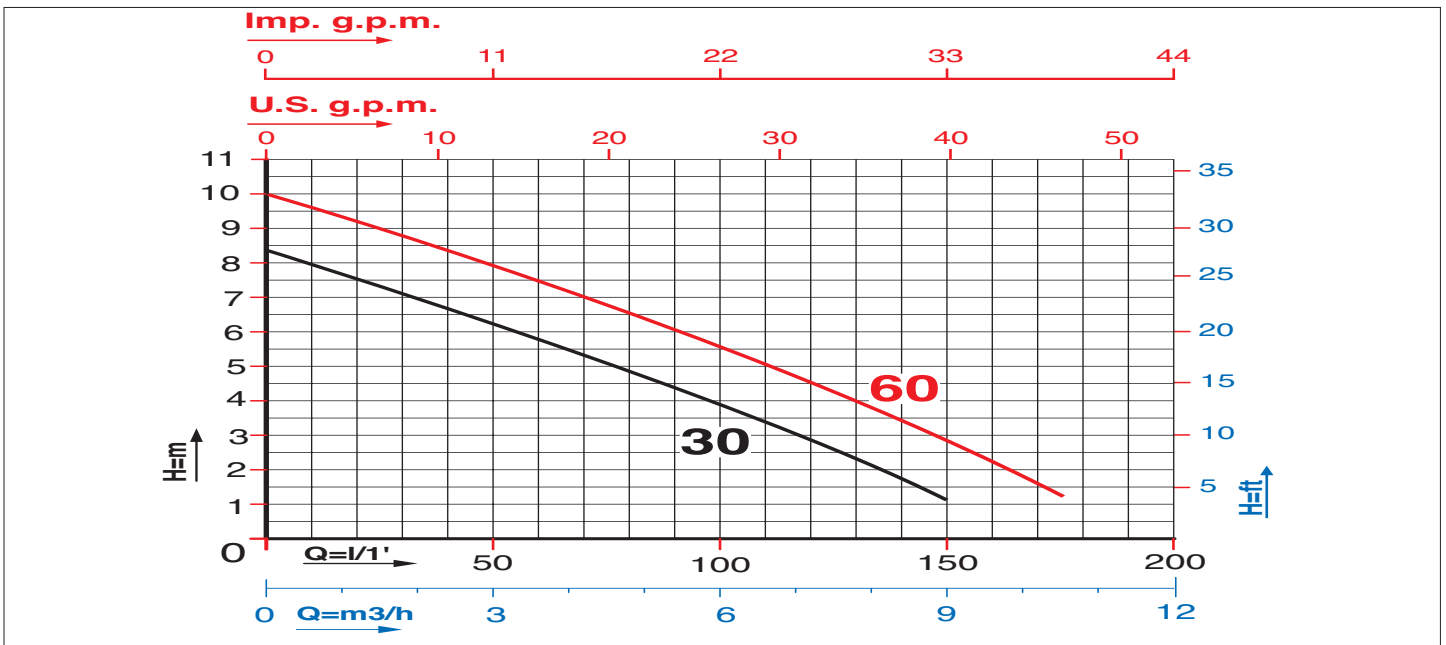

Caratteristiche di funzionamento a 2800 rpm 50Hz e 3450 rpm 60Hz - Performances at 2800 rpm 50 Hz and 3450 rpm 60 Hz  
 Le prestazioni valgono per liquidi con densità  $\rho = 1,0 \text{ kg/dm}^3$  ed una viscosità  $\nu = 1 \text{ mm}^2/\text{s}$  / The performance data holds true for liquids with a  $\rho = 1,0 \text{ kg/dm}^3$  density and a  $\nu = 1 \text{ mm}^2/\text{s}$  viscosity.

MODELLO MODEL	VOLTAGGIO VOLTAGE	DATI ELETTRICI / ELECTRICAL DATA						DATI IDRAULICI / HYDRAULIC DATA							
		P1 max	P2 nom.		I max	Condensatore Capacitor		m³/h		H (m)					
	50 Hz	kW	kW	HP	Ampere	µF	VC	0	1,5	3	4,5	6	7,5	9	10,5
MIZAR 30 M	1 x 220-230V	0,5	0,25	0,33	2,2	8,0	450	0	25	50	75	100	125	150	175
MIZAR 60 M	1 x 220-230V	0,7	0,45	0,6	3,0	10,0	450	8,0	7,2	6,2	5,2	4,0	2,6	1,0	---
MIZAR 60 T	3 x 380-440V	0,7	0,45	0,6	1,4	---	---	10,0	8,8	8,0	6,8	5,6	4,5	3,0	1,2
MIZAR 60 VOX M	1 x 220-230V	0,6	0,45	0,6	2,8	10,0	450	7,5	7,0	6,4	5,5	4,6	3,4	2,6	1,5
MIZAR 60 VOX T	3 x 380-440V	0,6	0,45	0,6	1,3	---	---	7,5	7,0	6,4	5,5	4,6	3,4	2,6	1,5

PREVALENZA TOTALE in METRI COLONNA ACQUA  
TOTAL PUMP HEAD AND WATER COLUMN HEIGHT in m.



**CARATTERISTICHE DI COSTRUZIONE:**

- MOTORE A SECCO RAFFREDDATO DAL LIQUIDO POMPATO
- DOPPIA TENUTA MECCANICA: DOPPIO ANELLO DI TENUTA LATO MOTORE, TENUTA MECCANICA A BAGNO D'OLIO LATO POMPA
- IMMERSIONE MASSIMA: mt. 5.
- GRADO DI PROTEZIONE IP 68.
- CLASSE DI ISOLAMENTO: F
- TEMPERATURA MAX.LIQUIDO POMPATO: 35°C
- PASSAGGIO LIBERO: 10 mm MIZAR 30 - 60  
20 mm MIZAR 60 VOX
- VERSIONI: Monofase: 220-277V/50Hz o 220-277V/60Hz con protettore termico incorporato e condensatore permanentemente inserito.
- CAVO STANDARD: 10 metri H07RN-F.
- MATERIALI:  
Consultare pagina 9

SPECIALI VOLTAGGI E FREQUENZE A RICHIESTA.

**DESIGN ENGINEERING:**

- SEMI WET MOTOR WATERCOOLED
- DOUBLE MECHANICAL SEAL: DOUBLE SEAL RING -ENGINE FACE  
OIL BATH MECHANICAL SEALS PUMP FACE
- PERMISSIBLE DRAUGHT OF WATER: 5 m
- IP 68 PROTECTION CLASS.
- CLASS "F" INSULATION.
- MAX. PUMPED LIQUID TEMPERATURE: 35°C
- BY PASS SECTION: 10 mm MIZAR 30 - 60  
20 mm MIZAR 60 VOX
- VERSIONS: Single Phase: 220-277V/50Hz or 220-277V/60Hz with built in thermal protection and permanent capacitor.
- STANDARD CABLE FEATURES: 10 metres H07RN-F.
- MATERIALS:  
Suitable at page 9

CUSTOMISED VOLTAGE AND FREQUENCY RATING AVAILABLE ON DEMAND.

**GALLEGGIANTE VERTICALE**

**VERTICAL FLOATER**

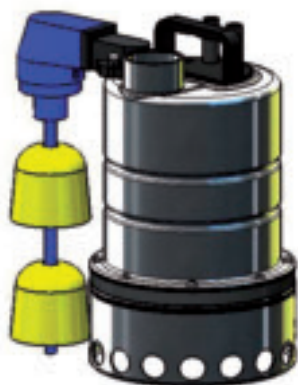

**VERTICAL 30 - 60 - 60 VOX**

MODELLO MODEL	VOLTAGGIO VOLTAGE 50 Hz	DATI ELETTRICI / ELECTRICAL DATA					
		P1max kW	P2 nom. kW HP		I max Ampere	Condensatore Capacitor µF VC	
<b>VERTICAL 30 M</b>	1 x 220-230V	0,5	0,25	0,33	2,2	8,0	450
<b>VERTICAL 60 M</b>	1 x 220-230V	0,7	0,45	0,6	3,0	10,0	450
<b>VERTICAL 60 VOX M</b>	1 x 220-230V	0,6	0,45	0,6	2,8	10,0	450

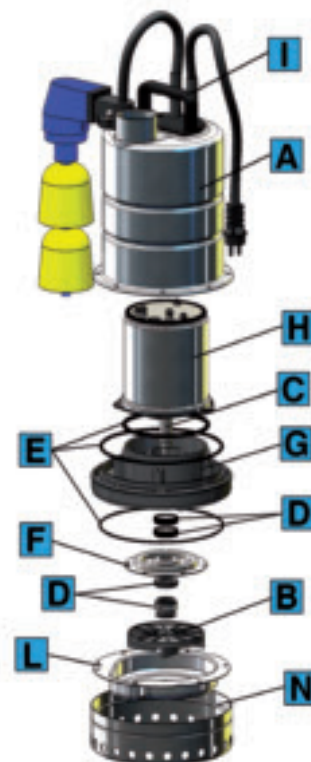



**CARATTERISTICHE DI COSTRUZIONE:**

- MOTORE A SECCO RAFFREDDATO DAL LIQUIDO POMPATO
- DOPPIA TENUTA MECCANICA: DOPPIO ANELLO DI TENUTA LATO MOTORE, TENUTA MECCANICA A BAGNO D'OLIO LATO POMPA
- IMMERSIONE MASSIMA: mt. 5.
- GRADO DI PROTEZIONE IP 68.
- CLASSE DI ISOLAMENTO: F
- TEMPERATURA MAX.LIQUIDO POMPATO: 35°C
- PASSAGGIO LIBERO: 2 mm.
- VERSIONI: Monofase: 220-277V/50Hz o 220-277V/60Hz con protettore termico incorporato e condensatore permanentemente inserito.
- CAVO STANDARD: 10 metri H07RN-F solo versione manuale.
- MATERIALI:  
Consultare a pagina 9

SPECIALI VOLTAGGI E FREQUENZE A RICHIESTA.

**DESIGN ENGINEERING:**

- SEMI WET MOTOR WATERCOOLED
- DOUBLE MECHANICAL SEAL: DOUBLE SEAL RING -ENGINE FACE OIL BATH MECHANICAL SEALS PUMP FACE
- PERMISSIBLE DRAUGHT OF WATER: 5 m
- IP 68 PROTECTION CLASS.
- CLASS "F" INSULATION.
- MAX. PUMPED LIQUID TEMPERATURE: 35°C
- BY PASS SECTION: 2 mm.
- VERSIONS: Single Phase: 220-277V/50Hz or 220-277V/60Hz with built in thermal protection and permanent capacitor.
- STANDARD CABLE FEATURES: 10 metres H07RN-F only the manual version
- MATERIALS:  
Cuitable at page 9

CUSTOMISED VOLTAGE AND FREQUENCY RATING AVAILABLE ON DEMAND.

**ASPIRAZIONE RIBASSATA 2 MM**

**LOWERED ASPIRATION 2MM**



MODELLO MODEL	VOLTAGGIO VOLTAGE	DATI ELETTRICI / ELECTRICAL DATA					
		P1 max	P2 nom.		I max	Condensatore Capacitor	
	50 Hz	kW	kW	HP	Ampere	µF	VC
<b>LOWER 30 M</b>	1 x 220-230V	0,5	0,25	0,33	2,2	8,0	450
<b>LOWER 60 M</b>	1 x 220-230V	0,7	0,45	0,6	3,0	10,0	450

**LOWER 30 - 60**

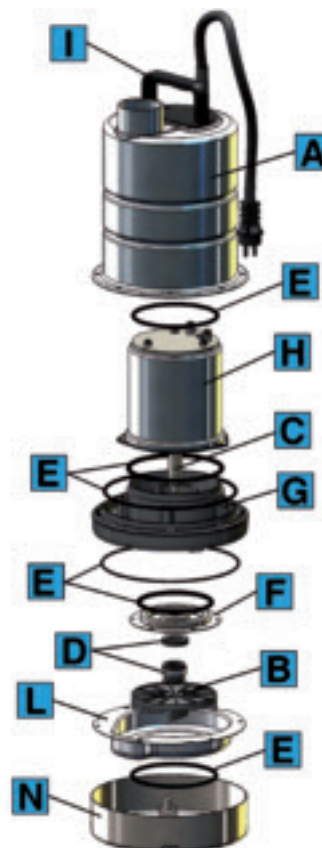

**DIMENSIONI E PESI / SIZE AND WEIGHT DATA :**

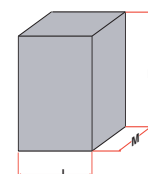
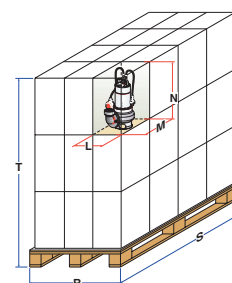
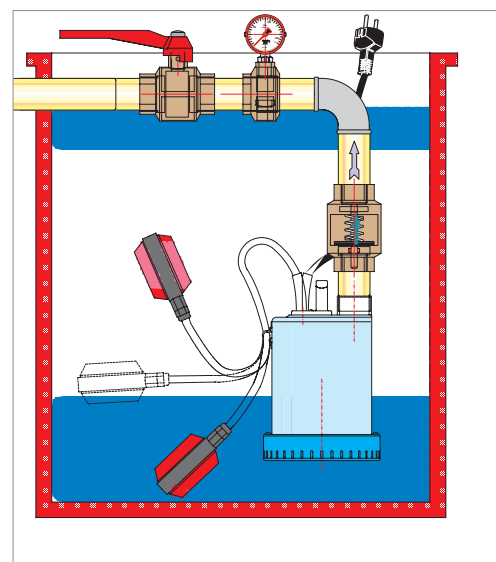
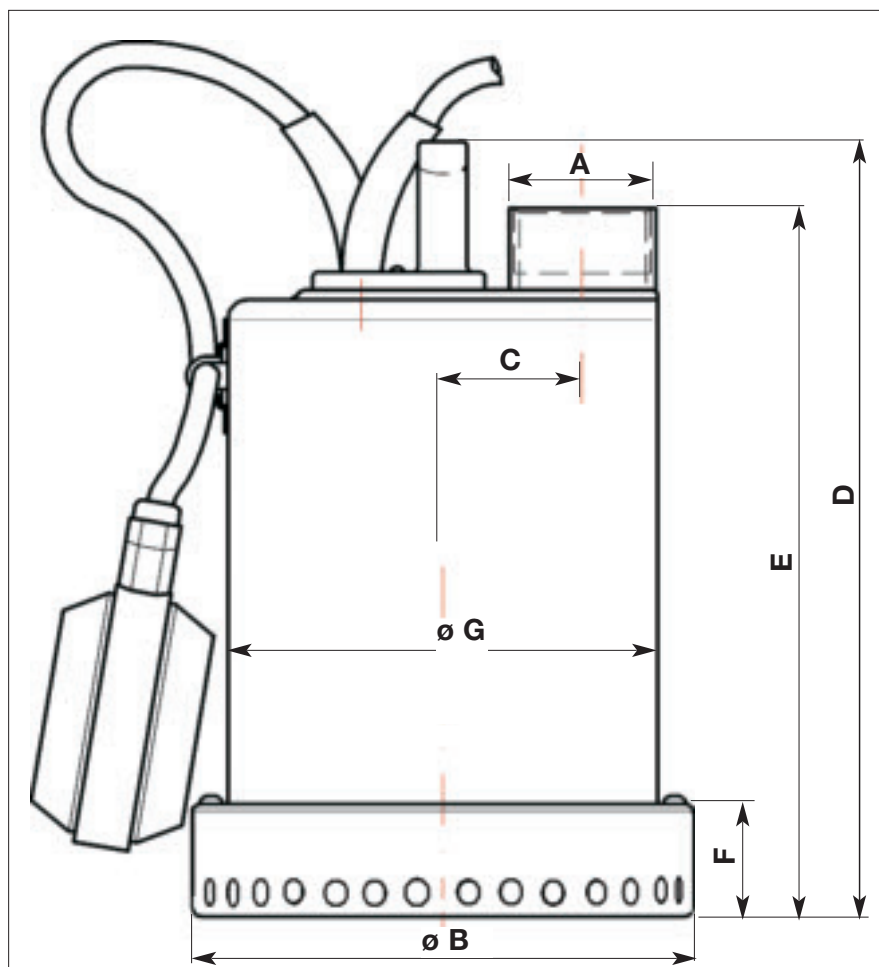

MODELLO MODEL	DIMENSIONI POMPA in mm. / PUMP DIMENSIONS in mm.						
	A	B	C	D	E	F	G
MIZAR 30	1" 1/4	154	41	249	228	50	132
MIZAR 60	1" 1/4	154	41	249	228	50	132
MIZAR 60 VOX	1" 1/4	154	41	282	261	74	132
VERTICAL 30	1" 1/4	154	41	249	228	50	132
VERTICAL 60	1" 1/4	154	41	249	228	50	132
VERTICAL 60 VOX	1" 1/4	154	41	282	261	74	132
LOWER 30	1" 1/4	154	41	241	228	40	132
LOWER 60	1" 1/4	154	41	241	228	40	132

MODELLO MODEL	DIMENSIONI SCATOLA / PACKING DIMENSIONS				DIMENSIONI PALLET / PALLET DIMENSIONS				
	L mm	M mm	N mm	Peso / Weight Kg	R mm	S mm	T mm	nr. scatole/cartons	Peso / Weight Kg
MIZAR 30	220	190	330	5,5	800	1200	1465	80	450
MIZAR 60	220	190	330	6,2	800	1200	1465	80	506
MIZAR 60 VOX	220	190	330	6,5	800	1200	1465	80	530
VERTICAL 30	220	190	330	5,5	800	1200	1465	80	450
VERTICAL 60	220	190	330	6,2	800	1200	1465	80	506
VERTICAL 60 VOX	220	190	330	6,5	800	1200	1465	80	530
LOWER 30	220	190	330	5,5	800	1200	1465	80	450
LOWER 60	220	190	330	6,2	800	1200	1465	80	506

# MIZAR/S aisi 316



## ELETTROPOMPE SOMMERSIBILI DRENAGGIO PER ACQUE CHIARE, SPORCHE E LIQUIDI AGGRESSIVI SUBMERSIBLE ELECTRIC PUMPS FOR WHITE, DIRTY WATER AND AGGRESSIVE LIQUIDS DRAINAGE

**PREVALENZA** ..... : 8,0 mt. - 10,0 mt.  
**PORTATA** ..... : 9,0 m<sup>3</sup>/h - 10,5 m<sup>3</sup>/h  
**POTENZA NOMINALE** : 0,25 kW (0,33 HP) ÷ 0,45 kW (0,6 HP)  
**PASSAGGIO SOLIDI FINO A 10 mm** (SERIE VOX 20 mm)

**PUMP HEAD** ..... : 8,0 mt ÷ 10,0 mt  
**DELIVERY** ..... : 9,0 m<sup>3</sup>/h ÷ 10,5 m<sup>3</sup>/h  
**RATED HORSEPOWER** : 0,25 kW (0,33 HP) ÷ 0,45 kW (0,6 HP)  
**SOLID MATTER BYPASS up to 10 mm** (SERIE VOX 20 mm)

### APPLICAZIONI

- SVUOTAMENTO DA ACQUE PIOVANE, D'INFILTRAZIONE, DI POZZETTI O VASCHE DI RACCOLTA.
- PRELIEVO DA VASCHE DI RACCOLTA DI ACQUE PIOVANE PER PICCOLE IRRIGAZIONI A SCORRIMENTO DI ORTI E DI GIARDINI.
- TRAVASO DI ACQUA CHIARA DA SERBATOI E VASCHE.
- POMPAGGIO DI ACQUE SPORCHE CON CORPI SOLIDI IN SOSPENSIONE (SOLO SERIE VOX).
- POMPAGGIO DI LIQUIDI AGGRESSIVI.

### APPLICATIONS

- RAIN, SEEPAGE, SUMP PIT AND CATCH TANK WATER PUMP OUT.
- GARDEN AND VEGETABLE-GARDEN MINI FLOOD IRRIGATION SYSTEM RAINWATER CATCH TANK PUMP DOWN.
- WHITE WATER PUMP OVER FROM RESERVOIRS AND VATS.
- PUMPING DIRTY WATER WITH POSSIBLE FLOATING SOLID CONTENTS (ONLY VOX SERIES).
- PUMPING AGGRESSIVE LIQUID.

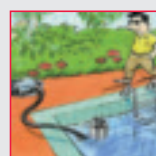
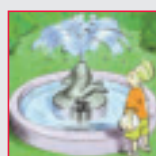
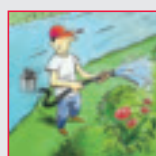

**AV ARVEN**

**CARATTERISTICHE DI COSTRUZIONE:**

- MOTORE A SECCO RAFFREDDATO DAL LIQUIDO POMPATO
- DOPPIA TENUTA MECCANICA: DOPPIO ANELLO DI TENUTA LATO MOTORE, TENUTA MECCANICA A BAGNO D'OLIO LATO POMPA
- IMMERSIONE MASSIMA: mt. 5.
- GRADO DI PROTEZIONE IP 68.
- CLASSE DI ISOLAMENTO: F
- TEMPERATURA MAX.LIQUIDO POMPATO: 35°C
- PASSAGGIO LIBERO: 10 mm MIZAR 30/S - 60/S  
20mm MIZAR 60/S VOX
- VERSIONI: Monofase:220-277V/50Hz o 220-277V/60Hz con protettore termico incorporato e condensatore permanentemente inserito.
- CAVO STANDARD:  
Monofase: 10 metri H05VVF per versione normale (aut.-man).

SPECIALI VOLTAGGI E FREQUENZE A RICHIESTA.

**DESIGN ENGINEERING:**

- SEMI WET MOTOR WATERCOOLED
- DOUBLE MECHANICAL SEAL: DOUBLE SEALING RING-ENGINE FACE, OIL BATH MECHANICAL SEALS PUMP FACE
- PERMISSIBLE DRAUGHT OF WATER: 5 m
- IP 68 PROTECTION CLASS.
- CLASS "F" INSULATION.
- MAX. PUMPED LIQUID TEMPERATURE: 35°C
- BY PASS SECTION: 10 mm MIZAR 30/S - 60/S  
20mm MIZAR 60/S VOX.
- VERSIONS: Single Phase: 220-277V/50 Hz or 220-277V/60Hz with built in thermal protection and permanent capacitor.
- STANDARD CABLE FEATURES:  
Single phase :10 metres H05VV-F for the standard version (automatic-manual)

CUSTOMISED VOLTAGE AND FREQUENCY RATING AVAILABLE ON DEMAND.

**TABELLA MATERIALI - MATERIALS TABLE:**

Pos.	Componente - Component	Materiale - Materials	
A	Carcassa esterna / External motor housing	ACCIAIO INOX AISI 316 - DIN 1.4401 / STAINLESS STEEL	
B	Girante / Impeller	MIZAR 30/S - 60/S	TECNOPOLIMERO TECNOPOLYMER
		MIZAR 60/S VOX	ACCIAIO INOX AISI 316 - DIN 1.4401 / STAINLESS STEEL
C	Albero (lato pompa) / Shaft (pump side)	ACCIAIO INOX AISI 316 - DIN 1.4401 / STAINLESS STEEL	
D	Tenuta meccanica Mechanical seal	Lato pompa / Pump face	CARBURO DI SILICIO - VITON SILICON CARBIDE - VITON
		Lato motore / Motor face	DOPPIO ANELLO DI TENUTA DOUBLE SEALING RING
E	O-ring	VITON	
F	Porta tenuta / Seal holder	ACCIAIO INOX AISI 316 - DIN 1.4401 / STAINLESS STEEL	
G	Porta motore / Motor holder	TECNOPOLIMERO TECNOPOLYMER	
H	Cassa motore / Motor housing	ACCIAIO INOX AISI 316 - DIN 1.4401 / STAINLESS STEEL	
I	Coperchio / Cover	TECNOPOLIMERO TECNOPOLYMER	
L	Diffusore / Diffuser	ACCIAIO INOX AISI 316 - DIN 1.4401 STAINLESS STEEL	
N	Base d'aspirazione / Suction base		

**MIZAR 30/S - 60/S**

**MIZAR 60/S VOX**

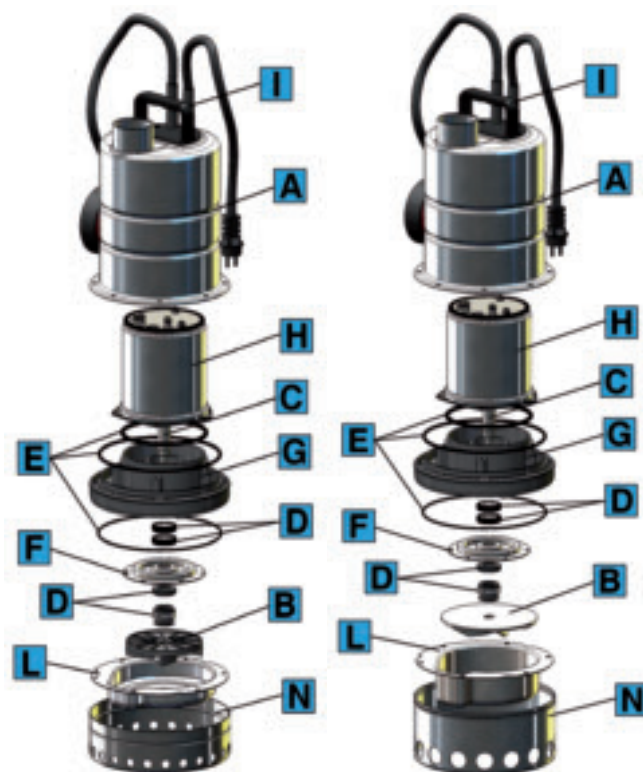

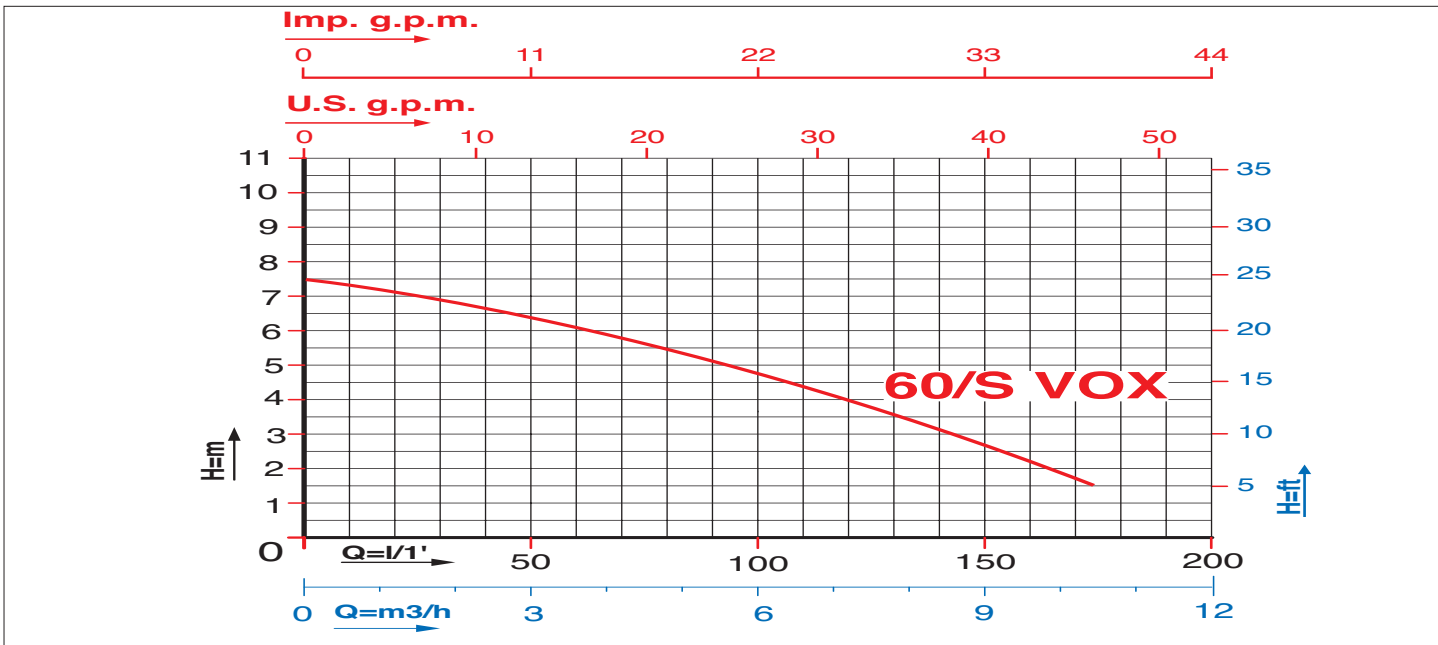
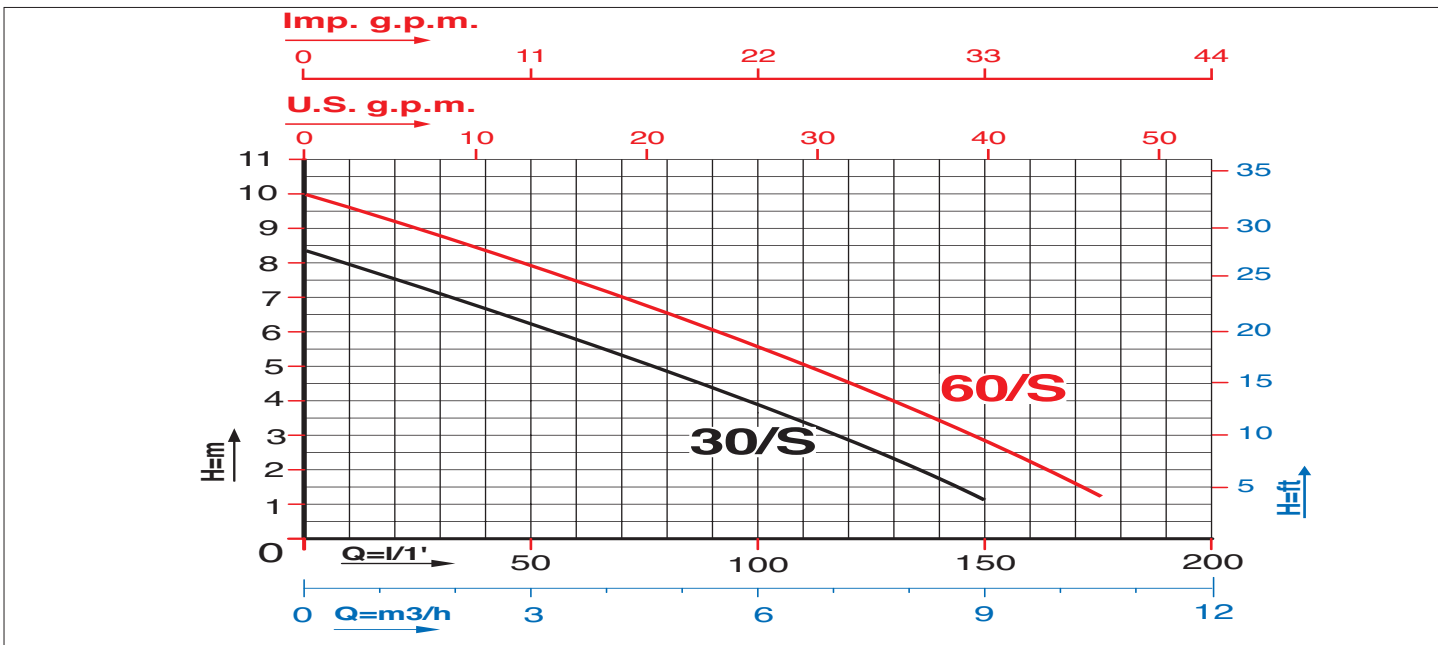

Caratteristiche di funzionamento a 2800 rpm 50Hz e 3450 rpm 60Hz - Performances at 2800 rpm 50 Hz and 3450 rpm 60 Hz  
 Le prestazioni valgono per liquidi con densità  $\rho = 1,0 \text{ kg/dm}^3$  ed una viscosità  $\nu = 1 \text{ mm}^2/\text{s}$  / The performance data holds true for liquids with a  $\rho = 1,0 \text{ kg/dm}^3$  density and a  $\nu = 1 \text{ mm}^2/\text{s}$  viscosity.

MODELLO MODEL	VOLTAGGIO VOLTAGE	DATI ELETTRICI / ELECTRICAL DATA						DATI IDRAULICI / HYDRAULIC DATA								
		P1 max	P2 nom.		I max	Condensatore Capacitor		m³/h		H (m)						
50 Hz		kW	kW	HP	Ampere	µF	VC	0	1,5	3	4,5	6	7,5	9	10,5	H (m)
MIZAR 30/S M	1 x 220-230V	0,5	0,25	0,33	2,2	8,0	450	0	25	50	75	100	125	150	175	
MIZAR 60/S M	1 x 220-230V	0,7	0,45	0,6	3,0	10,0	450	8,0	7,2	6,2	5,2	4,0	2,6	1,0	---	
MIZAR 60/S T	3 x 380-440V	0,7	0,45	0,6	1,4	---	---	10,0	8,8	8,0	6,8	5,6	4,5	3,0	1,2	
MIZAR 60/S VOX M	1 x 220-230V	0,6	0,45	0,6	2,8	10,0	450	7,5	7,0	6,4	5,5	4,6	3,4	2,6	1,5	
MIZAR 60/S VOX T	3 x 380-440V	0,6	0,45	0,6	1,3	---	---	7,5	7,0	6,4	5,5	4,6	3,4	2,6	1,5	

PREVALENZA TOTALE IN METRI COLONNA ACQUA  
TOTAL PUMP HEAD AND WATER COLUMN HEIGHT IN m.



**DIMENSIONI E PESI / SIZE AND WEIGHT DATA :**

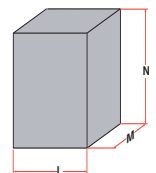
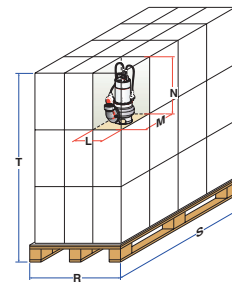
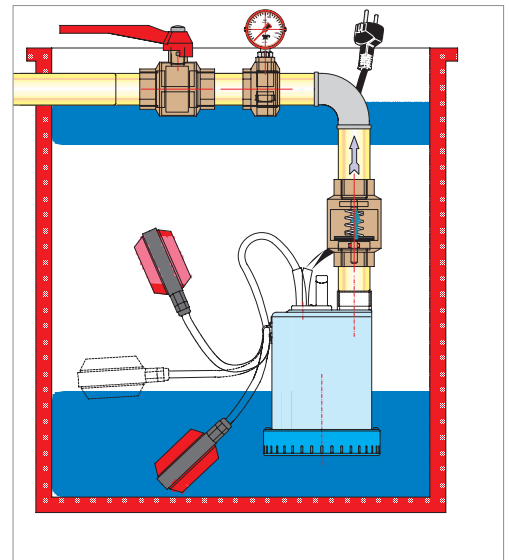
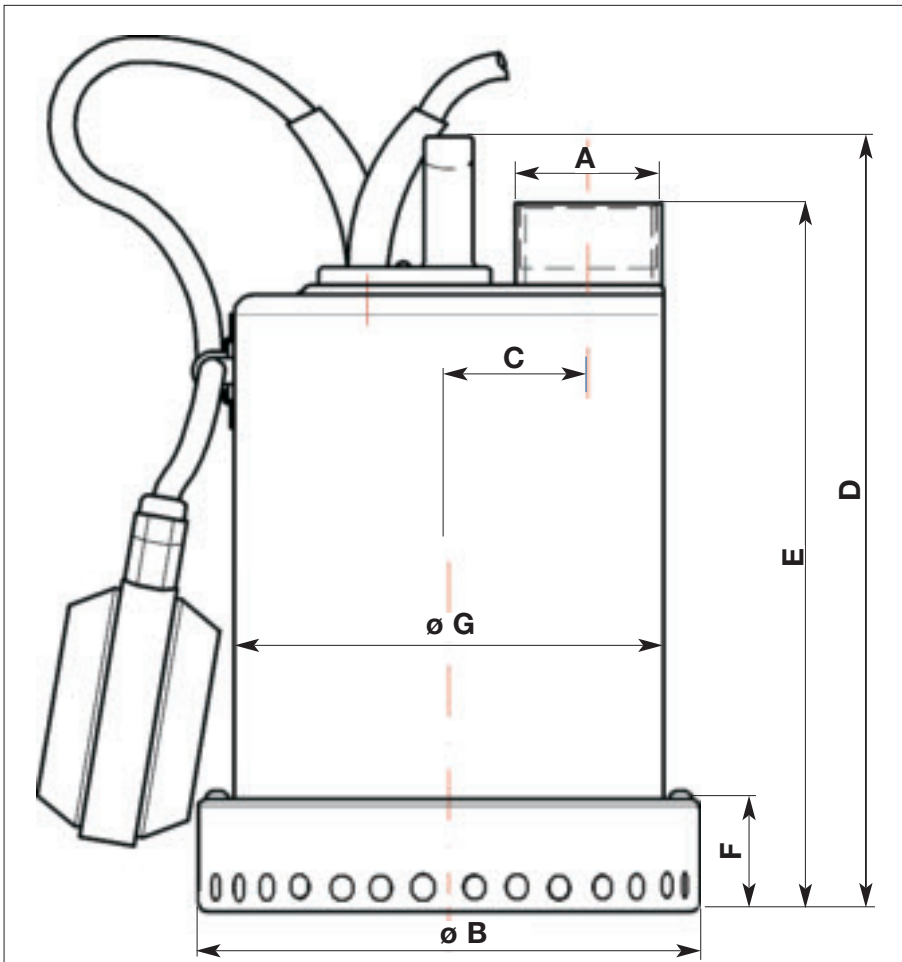

MODELLO MODEL	DIMENSIONI POMPA in mm. / PUMP DIMENSIONS in mm.						
	A	B	C	D	E	F	G
MIZAR/S 30	1" 1/4	154	41	249	228	50	132
MIZAR/S 60	1" 1/4	154	41	249	228	50	132
MIZAR/S 60 VOX	1" 1/4	154	41	282	261	74	132

MODELLO MODEL	DIMENSIONI SCATOLA / PACKING DIMENSIONS				DIMENSIONI PALLET / PALLET DIMENSIONS				
	L mm	M mm	N mm	Peso / Weight Kg	R mm	S mm	T mm	nr. scatole/cartons	Peso / Weight Kg
MIZAR 30/S	220	190	330	5,5	800	1200	1465	80	450
MIZAR 60/S	220	190	330	6,2	800	1200	1465	80	506
MIZAR 60/S VOX	220	190	330	6,5	800	1200	1465	80	530

# REGAL "PROFESSIONAL"



**ELETTROPOMPE SOMMERGIBILI DRENAGGIO PER ACQUE SPORCHE E LEGGERMENTE SABBIOSE  
SUBMERSIBLE ELECTRIC PUMPS FOR LIGHTLY SANDY FOUL WASTEWATER DRAINAGE**

**SERVIZIO CONTINUO ALTERNATO - ALTERNATED CONTINUE SERVICE**

**PREVALENZA** ..... : 10,5 mt. ÷ 16,5 mt.  
**PORTATA** ..... : 15,0 m<sup>3</sup>/h ÷ 27,0 m<sup>3</sup>/h  
**POTENZA NOMINALE** .... : 0,6 kW (0,8HP) ÷ 1,5 kW (2,2HP)  
**PASSAGGIO SOLIDI FINO A 10 mm.**  
**PASSAGGIO SOLIDI FINO A 30 mm. (SERIE VOX)**

**PUMP HEAD** ..... : 10,5 mt ÷ 16,5 mt  
**DELIVERY** ..... : 15,0 m<sup>3</sup>/h ÷ 27,0 m<sup>3</sup>/h  
**RATED HORSEPOWER** .... : 0,6 kW (0,8HP) ÷ 1,5 kW (2,2HP)  
**SOLID MATTER BYPASS up to 10 mm**  
**SOLID MATTER BYPASS up to 30 mm (VOX SERIES)**

## **APPLICAZIONI**

- SVUOTAMENTO DI CANTINE, AUTORIMESSE, SCANTINATI
- PARTICOLARMENTE ADATTE PER CANTIERISTICA.
- SVUOTAMENTO DI PISCINE VASCHE IN GENERE E SERBATOI.
- SVUOTAMENTO DA ACQUE PIOVANE, D'INFILTRAZIONE, DI POZZETTI O VASCHE DI RACCOLTA.
- IRRIGAZIONE ORTI E GIARDINI.

## **APPLICATIONS**

- CELLAR, GARAGE AND BASEMENT PUMP OUT.
- PARTICULARLY SUITED TO CONSTRUCTION WORK SITES
- SWIMMING POOLS, ALL SORTS OF VATS, TANKS AND RESERVOIR PUMP OUT.
- RAIN, SEEPAGE, SUMP PIT AND CATCH TANK WATER PUMP OUT.
- GARDEN AND VEGETABLE-GARDEN IRRIGATION.

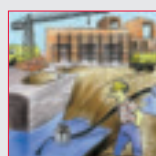
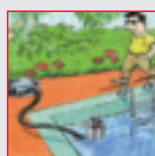
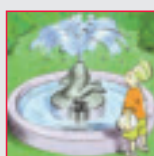
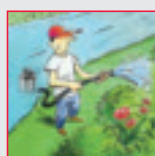

**AV ARVEN**



**CARATTERISTICHE DI COSTRUZIONE**

- ELETTRROPOMPA A DOPPIA CAMERA (MOTORE, TENUTA MECCANICA).
- MOTORE A BAGNO D'OLIO (BIODEGRADABILE E DIELETTRICO) PER RAFFREDDAMENTO E LUBRIFICAZIONE CUSCINETTI.
- ANELLO DI TENUTA LATO MOTORE.
- TENUTA MECCANICA A BAGNO D'OLIO
- IMMERSIONE MASSIMA: mt. 5.
- GRADO DI PROTEZIONE IP 68.
- CLASSE DI ISOLAMENTO: F
- TEMPERATURA MAX.LIQUIDO POMPATO: 35°C
- PASSAGGIO LIBERO: 10 mm. REGAL 80 - 100 - 150  
30 mm. REGAL 100 VOX - 150 VOX - 200 VOX
- VERSIONI: Monofase: 220-277V/50Hz o 220-277V/60Hz con protettore termico incorporato e condensatore permanentemente inserito.  
Trifase: 220-277V/50Hz o 380-480V/50Hz e 220-277V/60Hz o 380-480V/60Hz con protezione da sovraccarico a cura dell'utente.
- POTENZA MOTORE:  
DA 0,6kW (0,8 Hp ) a 1,1kW (1,5Hp) versioni monofase e trifase.  
DA 1,5kW (2 Hp ) versioni trifase.
- VERSIONI MONOFASI AUTOMATICHE CON GALLEGGIANTE O MANUALI SENZA GALLEGGIANTE
- CAVO STANDARD:  
Monofase:10 metri H07RN-F per versione normale (aut.-man).  
5 metri H07RN-F solo per versione automatica.(esclusa REGAL150)  
Trifase: 10 metri H07RN-F

SPECIALI VOLTAGGI E FREQUENZE A RICHIESTA.

**DESIGN ENGINEERING**

- DOUBLE CHAMBER ELECTRIC PUMP (MOTOR, MECHANICAL SEAL).
- OIL BATH MOTOR (BIODEGRADABLE AND DIELECTRIC) FOR COOLING AND BEARING LUBRICATION.
- SEALING RING - ENGINE FACE.
- OIL BATH MECHANICAL SEALS.
- PERMISSIBLE DRAUGHT OF WATER: 5 m
- IP 68 PROTECTION CLASS.
- CLASS "F" INSULATION
- MAX. PUMPED LIQUID TEMPERATURE: 35°C
- BY PASS SECTION: 10 mm. REGAL 80 - 100 - 150  
30 mm REGAL 100 VOX - 150 VOX - 200 VOX
- VERSIONS: Single Phase: 220-277V/50 Hz or 220-277V/60 Hz with built in thermal protection and permanent capacitor.  
Three Phase : 220-277 V/50Hz or 380-480V/50Hz and 220-277V/60Hz or 380-480V/60Hz with overload protection care of the User
- MOTOR POWER:  
From 0,6 kW (0,8 HP) to 1,1kW (1,5 HP) single phase and three phase versions.  
From 1,5 kW (2,0 HP) three phase versions.
- AUTOMATIC SINGLE PHASE VERSIONS WITH FLOATER OR MANUAL SINGLE PHASE VERSIONS, WITHOUT FLOATER
- STANDARD CABLE FEATURES:  
Single Phase:10 metres H07RN-F for the standard version (automatic-manual)  
5 metres H07RN-F only for the automatic version(excluded REGAL150)  
Three Phase: 10 metres H07RN-F

CUSTOMISED VOLTAGE AND FREQUENCY RATING AVAILABLE ON DEMAND.

**TABELLA MATERIALI / MATERIALS TABLE:**

Pos.	Componente / Component	Materiale / Materials
A	Carcassa esterna / External motor housing	ACCIAIO INOX AISI 304 - DIN 1.4301 STAINLESS STEEL
B	Girante / Impeller	
C	Albero (lato pompa) Shaft (pump side)	ACCIAIO INOX AISI 316 - DIN 1.4401 STAINLESS STEEL
D	Tenuta meccanica Mechanical seal	Lato pompa / Pump side CARBURO DI SILICIO-CERAMICA SILICON CARBIDE-CERAMIC
		Lato motore / Motor face ANELLO DI TENUTA NBR NBR SEAL RING
E	O-ring	NBR
G	Porta motore / Motor holder	ACCIAIO INOX AISI 304 - DIN 1.4301 STAINLESS STEEL
H	Carcassa motore / Motor housing	
I	Coperchio / Cover	
L	Diffusore / Diffuser	
N	Base / Base	

REGAL 80 - 100 - 150

REGAL 100-150-200 VOX

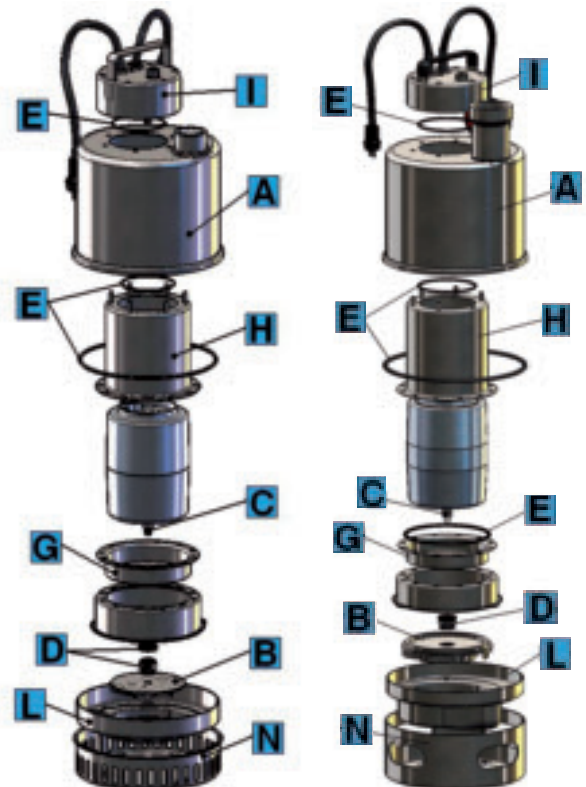

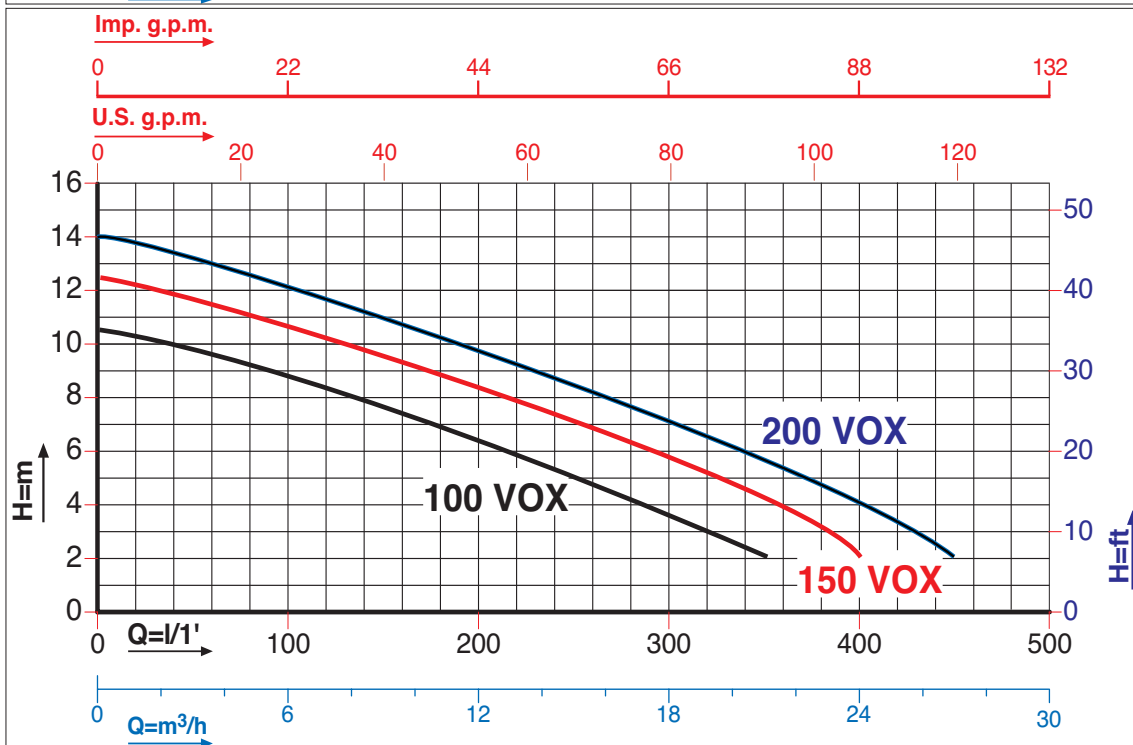
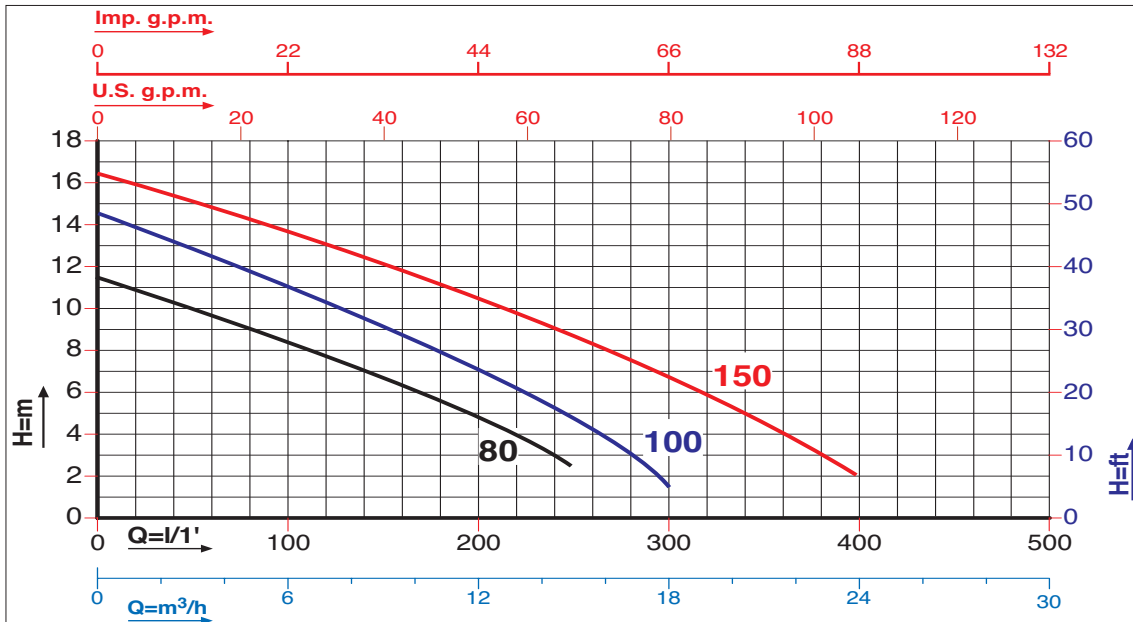

Caratteristiche di funzionamento a 2800 rpm 50Hz e 3450 rpm 60Hz - Performances at 2800 rpm 50 Hz and 3450 rpm 60 Hz  
 Le prestazioni valgono per liquidi con densità  $\rho = 1,0 \text{ kg/dm}^3$  ed una viscosità  $\nu = 1 \text{ mm}^2/\text{s}$  / The performance data holds true for liquids with a  $\rho = 1,0 \text{ kg/dm}^3$  density and a  $\nu = 1 \text{ mm}^2/\text{s}$  viscosity.

MODELLO MODEL	VOLTAGGIO VOLTAGE	DATI ELETTRICI / ELECTRICAL DATA						DATI IDRAULICI / HYDRAULIC DATA													
		P1 <sub>max</sub>	P2 nom.		I <sub>max</sub>	Condensatore Capacitor	m³/h														
			kW	kW			HP	Ampere	µF	VC	0	3	6	9	12	15	18	21	24	27	
REGAL 80 M	1 x 220-230V	1,1	0,6	0,8	4,5	16,0	450	H (m)	11,5	10,0	8,0	6,5	4,5	2,5	---	---	---	---	---	---	---
REGAL 80 T	3 x 380-440V	0,9	0,6	0,8	2,1	---	---		11,5	10,0	8,0	6,5	4,5	2,5	---	---	---	---	---	---	---
REGAL 100 M	1 x 220-230V	1,5	0,75	1,0	6,5	20,0	450		14,5	13,0	11,0	9,0	7,0	4,0	1,5	---	---	---	---	---	---
REGAL 100 T	3 x 380-440V	1,3	0,75	1,0	2,2	---	---		14,5	13,0	11,0	9,0	7,0	4,0	1,5	---	---	---	---	---	---
REGAL 150 M	1 x 220-230V	2,2	1,1	1,5	10,6	30,0	450		16,5	15,0	14,0	12,0	11,0	9,0	7,0	4,5	2,0	---	---	---	---
REGAL 150 T	3 x 380-440V	2,0	1,1	1,5	3,3	---	---		16,5	15,0	14,0	12,0	11,0	9,0	7,0	4,5	2,0	---	---	---	---
REGAL 100 VOX M	1 x 220-230V	1,5	0,75	1,0	6,8	20,0	450		10,5	10,0	8,5	7,5	6,5	5,0	3,5	2,0	---	---	---	---	---
REGAL 100 VOX T	3 x 380-440V	1,5	0,75	1,0	2,4	---	---		10,5	10,0	8,5	7,5	6,5	5,0	3,5	2,0	---	---	---	---	---
REGAL 150 VOX M	1 x 220-230V	2,2	1,1	1,5	9,0	30,0	450		12,5	11,5	10,5	9,5	8,0	7,0	6,0	4,0	2,0	---	---	---	---
REGAL 150 VOX T	3 x 380-440V	2,0	1,1	1,5	3,3	---	---		12,5	11,5	10,5	9,5	8,0	7,0	6,0	4,0	2,0	---	---	---	---
REGAL 200 VOX M	1 x 220-230V	2,4	1,5	2,0	10,5	30,0	450		14,0	13,0	12,0	11,0	10,0	8,5	7,0	5,5	4,0	2,0	---	---	---
REGAL 200 VOX T	3 x 380-440V	2,2	1,5	2,0	3,8	---	---		14,0	13,0	12,0	11,0	10,0	8,5	7,0	5,5	4,0	2,0	---	---	---

PREVALENZA TOTALE in METRI COLONNA ACQUA / TOTAL PUMP HEAD AND WATER COLUMN HEIGHT IN m.

**DIMENSIONI E PESI / SIZE AND WEIGHT DATA:**

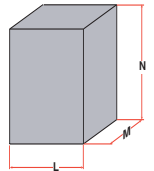
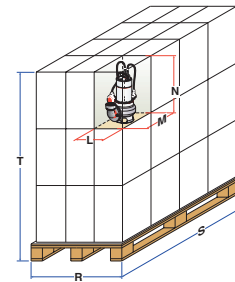
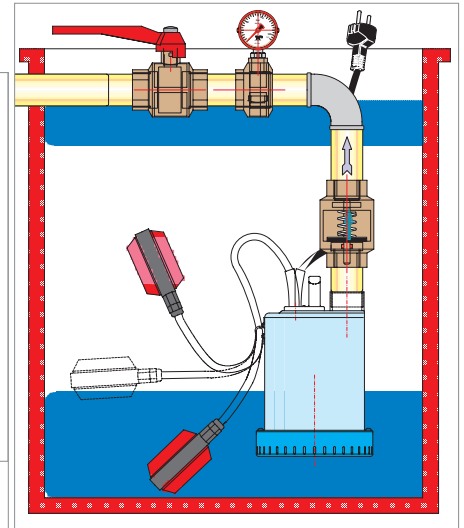
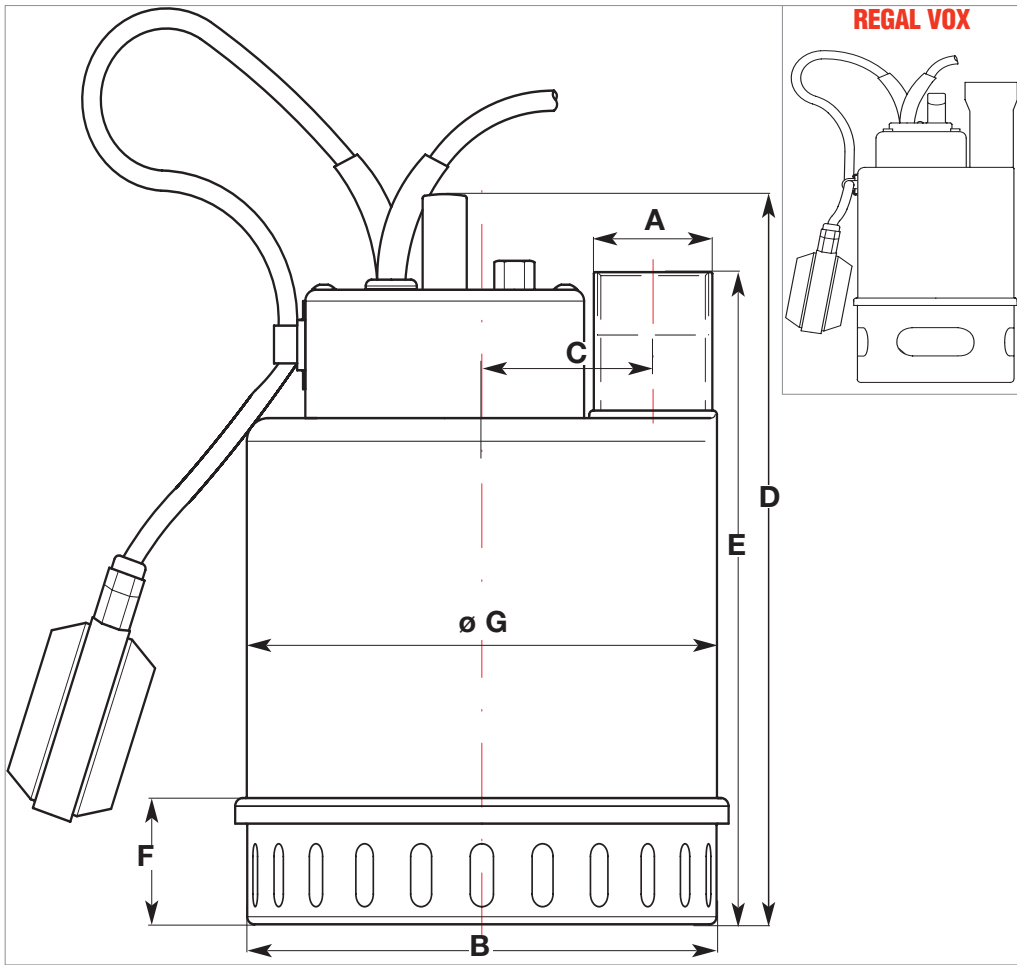

MODELLO / MODEL	DIMENSIONI POMPA in mm. / PUMP DIMENSIONS in mm.						
	A	B	C	D	E	F	G
REGAL 80	1" 1/2	212,4	73	290,2	259,2	50,5	202
REGAL 100	1" 1/2	212,4	73	290,2	259,2	50,5	202
REGAL 150	2"	212,4	73	326,7	294,7	50,5	202
REGAL 100 VOX	1 1/2"	204	73	344,2	325,2	106	202
REGAL 150 VOX	2"	204	73	384,7	393,2	106	203
REGAL 200 VOX	2"	204	73	384,7	393,2	106	203

MODELLO MODEL	DIMENSIONI SCATOLA / PACKING DIMENSIONS				DIMENSIONI PALLET / PALLET DIMENSIONS				
	L mm	M mm	N mm	Peso / Weight Kg	R mm	S mm	T mm	nr. scatole/cartons	Peso / Weight Kg
REGAL 80	220	320	340	9,0	800	1200	1400	48	447
REGAL 100	220	320	340	11,0	800	1200	1400	48	543
REGAL 150	250	290	460	18,0	800	1200	1400	36	663
REGAL 100 VOX	260	320	480	13,0	800	1200	1400	36	483
REGAL 150 VOX	260	320	480	20,0	800	1200	1400	36	735
REGAL 200 VOX	260	320	480	21,0	800	1200	1400	36	771

# KONTRACT

180 - 250



## **ELETTROPOMPE SOMMERGIBILI DRENAGGIO PER CANTIERISTICA SUBMERSIBLE ELECTRIC PUMPS FOR CONSTRUCTION WORK SITE DRAINAGE**

**PREVALENZA** ..... : 17,5 mt. ÷ 18,5 mt.  
**PORTATA** ..... : 30 m<sup>3</sup>/h ÷ 36 m<sup>3</sup>/h  
**POTENZA NOMINALE** : 1,1 kW (1,5HP) ÷ 1,8 kW (2,5HP)

**PUMP HEAD** ..... : 17,5 mt ÷ 18,5 mt  
**DELIVERY** ..... : 30,0 m<sup>3</sup>/h ÷ 36,0 m<sup>3</sup>/h  
**RATED HORSEPOWER** : 1,1 kW (1,5HP) ÷ 1,8 kW (2,5HP)

### **APPLICAZIONI**

- DRENAGGIO DI CANTIERI EDILI E DI CUNICOLI
- IDONEE PER IL PROSCIUGAMENTO DI SCANTINATI E BOX.
- MOVIMENTAZIONE DI ACQUE MODERATAMENTE CARICHE CONTENENTI MATERIALI ANCHE ABRASIVI, IMPIANTI DI IRRIGAZIONE, ACQUE PIOVANE E DI FALDA.

### **APPLICATIONS**

- WORK SITE, TRENCH DUCTS AND UNDERGROUND PASSAGE PUMP OUT
- SUITED TO CELLAR, GARAGE AND BASAMENT PUMP OUT.
- HANDLING OF MODERATELY FOUL WATER WITH MATERIAL AND/OR ABRASIVE MATERIAL CONTENTS.

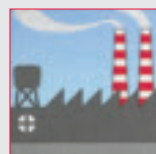
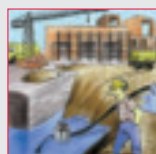

**AV ARVEN**

**CARATTERISTICHE DI COSTRUZIONE**

- MOTORE A BAGNO D'OLIO (BIODEGRADABILE E DIELETTRICO) PER RAFFREDDAMENTO E LUBRIFICAZIONE CUSCINETTI.
- DOPPIA TENUTA MECCANICA: LATO MOTORE A BAGNO D'OLIO. LATO POMPA A BAGNO D'ACQUA.
- IMMERSIONE MASSIMA: mt. 5.
- GRADO DI PROTEZIONE IP 68.
- CLASSE DI ISOLAMENTO: F.
- TEMPERATURA MAX. LIQUIDO POMPATO: 35°C .
- PASSAGGIO LIBERO: 10 mm.
- MONOFASE 220 - 277V/50Hz o 220 – 277V / 60 Hz:
  - con protettore termico incorporato e condensatore permanentemente inserito. (HP 1,5)
  - con protettore termico incorporato e quadro elettrico in materiale plastico completo di condensatore e interruttore. (HP 2,5)
- TRIFASE: 220-277V/50Hz o 380-480V/50Hz e 220-277V/60Hz o 380-480V/60Hz con protezione da sovraccarico a cura dell'utente.
- POTENZA MOTORE: da 1,1 kW (1,5 HP) a 1,8 kW (2,5Hp) versioni monofase e trifase.
- VERSIONI MONOFASI: automatiche con galleggiante. manuali senza galleggiante.
- CAVO STANDARD (CON GALLEGGIANTE MANUALE):
  - Monofase: 10 metri H07RN-F senza spina. (HP 1,5)
  - 10 metri H07RN-F completa di quadro elettrico con spezzone cavo 0,7 metri senza spina. (HP 2,5)
  - Trifase: 10 metri H07RN-F senza spina.

SPECIALI VOLTAGGI E FREQUENZE A RICHIESTA.

**ACCESSORI DISPONIBILI A RICHIESTA:**

- QUADRO ELETTRICO MONOFASE CON 2 CONDENSATORI (AVVIO/MARCIA).
- QUADRO ELETTRICO TRIFASE DI PROTEZIONE E COMANDO AUTOMATICO A MEZZO DI GALLEGGIANTE ELETTROMECCANICO .
- GALLEGGIANTE 10-20 mt. DI CAVO.
- RACCORDI E PORTA GOMMA RAPIDI DA 2" e 3" IN ALLUMINIO RAPIDO.

**DESIGN ENGINEERING**

- OIL BATH MOTOR (BIODEGRADABLE AND DIELECTRIC OIL) FOR COOLING AND BEARING LUBRICATION.
- DOUBLE MECHANICAL SEALS: ENGINE FACE: OIL BATH. PUMP FACE: WATER BATH.
- PERMISSIBLE DRAUGHT OF WATER: 5 m.
- IP 68 PROTECTION CLASS.
- CLASS "F" INSULATION.
- MAX. PUMPED LIQUID TEMPERATURE: 35°C.
- BY PASS SECTION: 10 mm.
- SINGLE PHASE 220 - 277V/50Hz or 220 – 277V / 60 Hz:
  - with built in thermal protection and permanent capacitor. (HP 1,5)
  - with built in thermal protection and plastic casing power supply box comprising capacitor and switch. (HP 2,5)
- THREE PHASES: 220-277V/50 Hz or 380-480V/50Hz and 220-277V/60Hz or 380-480V/60Hz with overload protection care of the User.
- MOTOR POWER: From 1,1 kW(1,5 HP) to 1,5 kW (2,5HP) single phase and three phase versions.
- SINGLE PHASE VERSIONS: automatic version with floater. manual version without floater.
- STANDARD CABLE FEATURES (WUTH MANUAL FLOATER):
  - Single Phase: 10 metres H07RN-F without plug. (HP 1,5)
  - 10 metres H07RN-F complete with power supply box 0.7 m cable section, without connection plug. (HP 2,5)
  - Three phase: 10 metres H07RN-F without plug.

CUSTOMISED VOLTAGE AND FREQUENCY RATING AVAILABLE ON DEMAND.

**ACCESSORIES AVAILABLE ON DEMAND:**

- SINGLE PHASE ELECTRICAL BOX WITH 2 CAPACITORS (STARTER/RUN).
- THREE PHASES ELECTRICAL SAFETY POWER SUPPLY BOX WITH AUTOMATIC ELECTROMECHANICAL FLOATER CONTROLS.
- FLOATER CABLE: 10-20 metres.
- 2" AND 3" QUICK-UNION ALUMINIUM CONNECTORS AND RUBBER PIECE HOLDERS.

**TABELLA MATERIALI / MATERIALS TABLE:**

Pos.	Componente / Component	Materiale / Materials
A	Carcassa esterna / External motor housing	ACCIAIO INOX AISI 304 - DIN 1.4301 STAINLESS STEEL
B	Girante / Impeller	ACCIAIO INOX SPECIALE SPECIAL STAINLESS STEEL
C	Albero (lato pompa) / Shaft (pump side)	ACCIAIO INOX AISI 316 - DIN 1.4401 / STAINLESS STEEL
D	Doppia tenuta meccanica Double mechanical seal	Lato pompa / Pump face CARBURO DI SILICIO-CERAMICA / SILICON CARBIDE-CERAMIC
		Lato motore / Motor face GRAFITE-CERAMICA GRAPHITE-CERAMIC
E	O-ring	NBR
H	Carcassa motore / Motor housing	ACCIAIO INOX AISI 304 - DIN 1.4301 / STAINLESS STEEL
I	Coperchio / Cover	ACCIAIO INOX AISI 304 - DIN 1.4301 / STAINLESS STEEL
L	Diffusore / Diffuser	HNBR CON ANIMA ACCIAIO HNBR WITH CORE STEEL
N	Base aspirazione / Suction base	ACCIAIO INOX AISI 304 - DIN 1.4301 / STAINLESS STEEL
R	Flangia inferiore / Lower flange	ALLUMINIO CON TRATTAMENTO SPECIALE ALUMINIUM WITH SPECIAL TREATMENT

**KONTRACT 180 - 250**

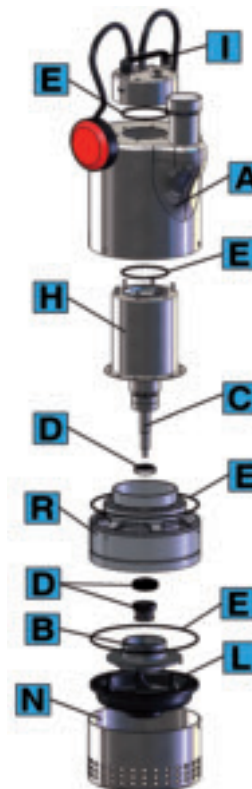



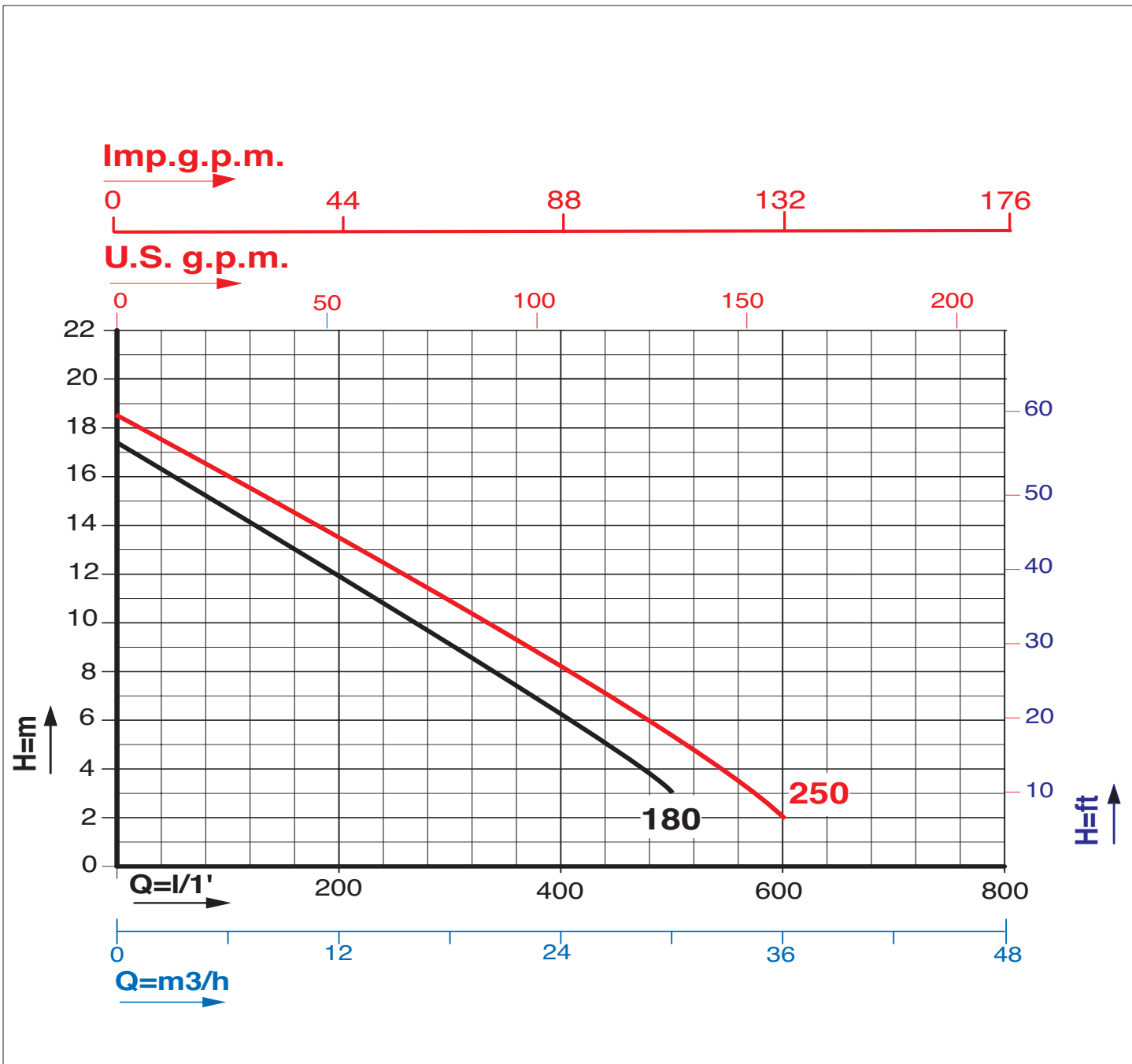

Caratteristiche di funzionamento a 2800 rpm 50Hz e 3450 rpm 60Hz - Performances at 2800 rpm 50 Hz and 3450 rpm 60 Hz

Le prestazioni valgono per liquidi con densità  $\rho = 1,0 \text{ kg/dm}^3$  ed una viscosità  $\nu = 1 \text{ mm}^2/\text{s}$  / The performance data holds true for liquids with a  $\rho = 1,0 \text{ kg/dm}^3$  density and a  $\nu = 1 \text{ mm}^2/\text{s}$  viscosity.

MODELLO MODEL	VOLTAGGIO VOLTAGE 50 Hz	DATI ELETTRICI / ELECTRICAL DATA						DATI IDRAULICI / HYDRAULIC DATA						
		P1 max	P2 nom.		I max	Condensatore Capacitor		m³/h	0	3	12	21	30	36
		kW	kW	HP	Ampere	µF	VC	l/min.	0	50	200	350	500	600
KONTRACT 180 M	1 x 220-230V	2,2	1,1	1,5	9,5	30,0	450	H (m)	17,5	16,0	12,0	8,0	3,0	
KONTRACT 180 T	3 x 380-400V	2,0	1,1	1,5	3,3	---	---		17,5	16,0	12,0	8,0	3,0	
KONTRACT 250 M	1 x 220-230V	3,0	1,8	2,5	13,5	40,0	450		18,5	17,0	14,0	9,5	5,0	2,0
KONTRACT 250 T	3 x 380-400V	2,8	1,8	2,5	4,6	---	---		18,5	17,0	14,0	9,5	5,0	2,0

PREVALENZA TOTALE IN METRI COLONNA ACQUA / TOTAL PUMP HEAD AND WATER COLUMN HEIGHT IN M.

**DIMENSIONI E PESI / SIZE AND WEIGHT DATA:**

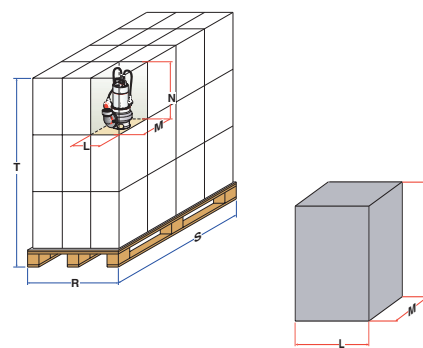
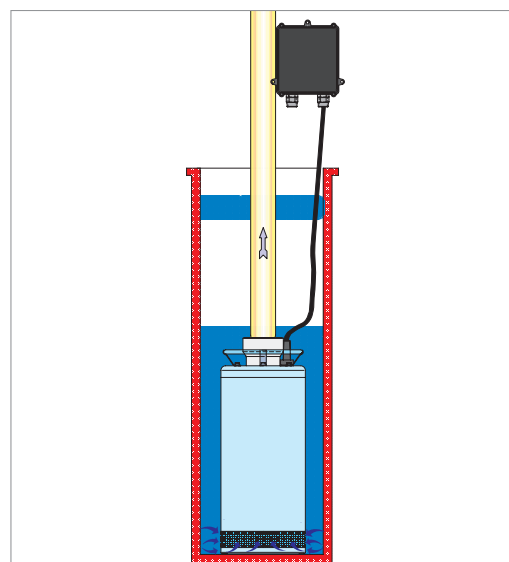
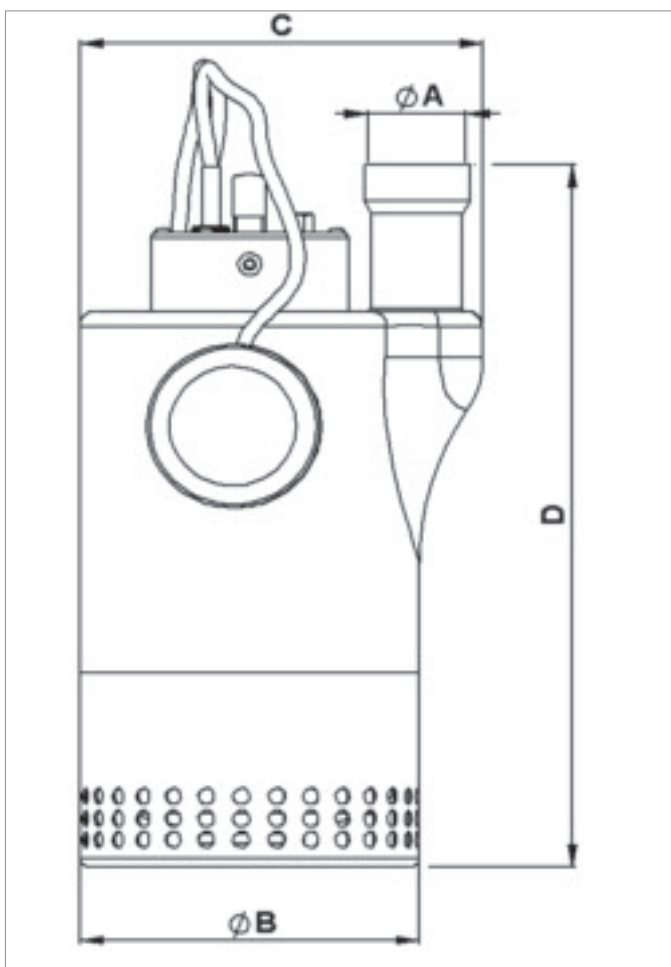

MODELLO / MODEL	DIMENSIONI POMPA in mm. / PUMP DIMENSIONS in mm.			
	A	B	C	D
KONTRACT 180 M	2"	203	230	446
KONTRACT 180 T	2"	203	230	446
KONTRACT 250 M	2"	203	230	446
KONTRACT 250 T	2"	203	230	446

MODELLO / MODEL	DIMENSIONI SCATOLA / PACKING DIMENSIONS				DIMENSIONI PALLET / PALLET DIMENSIONS				
	L mm.	M mm.	N mm.	Peso / Weight Kg.	R mm.	S mm.	T mm.	nr. scatole/cartons	Peso / Weight Kg.
KONTRACT 180 M	650	370	260	21,0	800	1200	1450	20	420
KONTRACT 180 T	650	370	260	21,0	800	1200	1450	20	420
KONTRACT 250 M	650	370	260	25,0	800	1200	1450	20	500
KONTRACT 250 T	650	370	260	25,0	800	1200	1450	20	500



# KONTRACT

300 - 400 - 600



## **ELETTROPOMPE SOMMERSIBILI DRENAGGIO PER CANTIERISTICA SUBMERSIBLE ELECTRIC PUMPS FOR CONSTRUCTION WORK SITE DRAINAGE**

**PREVALENZA** ..... : 20,0 mt. ÷ 23,0 mt.  
**PORTATA** ..... : 54,0 m<sup>3</sup>/h ÷ 84,0 m<sup>3</sup>/h  
**POTENZA NOMINALE** : 2,25 kW (3HP) ÷ 4,5 kW (6HP)

**PUMP HEAD** ..... : 20,0 mt ÷ 23,0 mt  
**DELIVERY** ..... : 54,0 m<sup>3</sup>/h ÷ 84,0 m<sup>3</sup>/h  
**RATED HORSEPOWER** : 2,25 kW (3,0HP) ÷ 4,5 kW (6,0HP)

### **APPLICAZIONI**

- DRENAGGIO DI CANTIERI EDILI E DI CUNICOLI.
- IDONEE PER IL PROSCIUGAMENTO DI SCANTINATI E BOX.
- MOVIMENTAZIONE DI ACQUE MODERATAMENTE CARICHE CONTENENTI MATERIALI ANCHE ABRASIVI, IMPIANTI DI IRRIGAZIONE, ACQUE PIOVANE E DI FALDA.

### **APPLICATIONS**

- WORK SITE, TRENCH DUCTS AND UNDERGROUND PASSAGE PUMP OUT.
- SUITED TO CELLAR, GARAGE AND BASEMENT PUMP OUT.
- HANDLING OF MODERATELY FOUL WATER WITH MATERIAL AND/OR ABRASIVE MATERIAL CONTENTS.

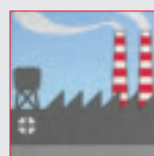
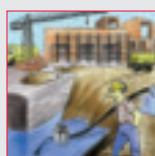
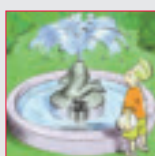

**AV ARVEN**

**CARATTERISTICHE DI COSTRUZIONE**

- MOTORE A BAGNO D'OLIO (BIODEGRADABILE E DIELETRICO) PER RAFFREDDAMENTO E LUBRIFICAZIONE CUSCINETTI.
- DOPPIA TENUTA MECCANICA: LATO MOTORE A BAGNO D'OLIO. LATO POMPA A BAGNO D'ACQUA.
- IMMERSIONE MASSIMA: mt. 5.
- GRADO DI PROTEZIONE IP 68.
- CLASSE DI ISOLAMENTO: F.
- TEMPERATURA MAX. LIQUIDO POMPATO: 35°C .
- PASSAGGIO LIBERO: 10 mm.
- MONOFASE 220 - 277V/50Hz o 220 – 277V / 60 Hz, con protettore termico incorporato e quadro elettrico in materiale plastico completo di condensatore e interruttore.
- TRIFASE 220-277V/50Hz o 380-480V/50Hz e 220-277V/60Hz o 380-480V/60Hz con protezione da sovraccarico a cura dell'utente.
- POTENZA MOTORE:  
da 2,25 kW (3,0 Hp) versioni monofase e trifase.  
da 3,0 kW (4,0 HP) a 4,5kW (6,0 HP) solo versione trifase.
- VERSIONI MONOFASI MANUALI (senza galleggiante).
- CAVO STANDARD:  
Monofase: 10 metri H07RN-F completa di quadro elettrico con spezzone cavo 0,7 metri senza spina.  
Trifase: 10 metri H07RN-F senza spina.

SPECIALI VOLTAGGI E FREQUENZE A RICHIESTA.

**ACCESSORI DISPONIBILI A RICHIESTA:**

- QUADRO ELETTRICO MONOFASE CON 2 CONDENSATORI (AVVIO/MARCIA).
- QUADRO ELETTRICO MONOFASE E TRIFASE DI PROTEZIONE E COMANDO AUTOMATICO A MEZZO DI GALLEGGIANTE ELETTROMECCANICO.
- GALLEGGIANTE 10-20 mt. DI CAVO.
- RACCORDI E PORTA GOMMA RAPIDI DA 2" e 3" IN ALLUMINIO RAPIDO.

**DESIGN ENGINEERING**

- OIL BATH MOTOR (BIODEGRADABLE AND DIELECTRIC OIL) FOR COOLING AND BEARING LUBRICATION.
- DOUBLE MECHANICAL SEALS: ENGINE FACE: OIL BATH. PUMP FACE: WATER BATH.
- PERMISSIBLE DRAUGHT OF WATER: 5 m.
- IP 68 PROTECTION CLASS.
- CLASS "F" INSULATION.
- MAX. PUMPED LIQUID TEMPERATURE: 35°C.
- BY PASS SECTION: 10 mm.
- SINGLE PHASE 220 - 277V/50Hz or 220 – 277V / 60 Hz, with built in thermal protection and plastic casing power supply box comprising capacitor and switch.
- THREE PHASES: 220-277V/50 Hz or 380-480V/50Hz and 220-277V/60Hz or 380-480V/60Hz with overload protection care of the User.
- MOTOR POWER:  
From 2,25 kW (3,0 HP) single phase and three phases versions.  
From 3,0 kW (4,0 HP) to 4,5 kW (6,0 HP) only three phases version.
- SINGLE PHASE VERSIONS only manual (without floater).
- STANDARD CABLE FEATURES:  
Single Phase: 10 metres H07RN-F complete with power supply box 0.7 m cable section, without connection plug.  
Three phases: 10 metres H07RN-F without plug.

CUSTOMISED VOLTAGE AND FREQUENCY RATING AVAILABLE ON DEMAND.

**ACCESSORIES AVAILABLE ON DEMAND:**

- SINGLE PHASE ELECTRICAL BOX WITH 2 CAPACITORS (STARTER/RUN).
- SINGLE PHASE AND THREE PHASE ELECTRICAL SAFETY POWER SUPPLY BOX WITH AUTOMATIC ELECTROMECHANICAL FLOATER CONTROLS.
- FLOATER CABLE: 10-20 metres.
- 2" AND 3" QUICK-UNION ALUMINIUM CONNECTORS AND RUBBER PIECE HOLDERS.

**TABELLA MATERIALI / MATERIALS TABLE:**

Pos.	Componente / Component	Materiale / Materials
A	Carcassa esterna / External motor housing	ACCIAIO INOX AISI 304 - DIN 1.4301 STAINLESS STEEL
B	Girante / Impeller	ACCIAIO INOX SPECIALE SPECIAL STAINLESS STEEL
C	Albero (lato pompa) / Shaft (pump side)	ACCIAIO INOX AISI 316 - DIN 1.4401 / STAINLESS STEEL
D	Doppia tenuta meccanica Double mechanical seal	Lato pompa / Pump face CARBURO DI SILICIO-CARBURO DI SILICIO / SILICON CARBIDE-SILICON CARBIDE
		Lato motore / Motor face GRAFITE-CERAMICA GRAPHITE-CERAMIC
E	O-ring	NBR
H	Carcassa motore / Motor housing	ACCIAIO INOX AISI 304 - DIN 1.4301 / STAINLESS STEEL
I	Coperchio / Cover	GHISA (G20) CAST IRON
L	Diffusore / Diffuser	HNBR CON ANIMA ACCIAIO HNBR WITH CORE STEEL
N	Base aspirazione / Suction base	ACCIAIO INOX AISI 304 - DIN 1.4301 / STAINLESS STEEL
R	Flangia inferiore / Lower flange	GHISA (G20) CAST IRON
S	Flangia superiore / Upper flange	

**KONTRACT 300 - 400 - 600**

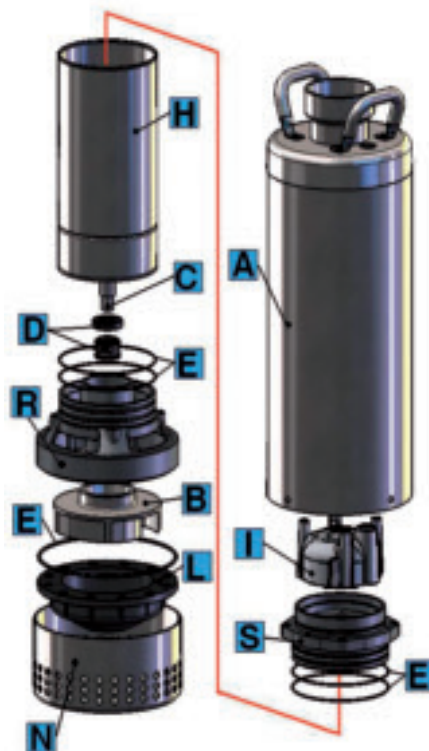

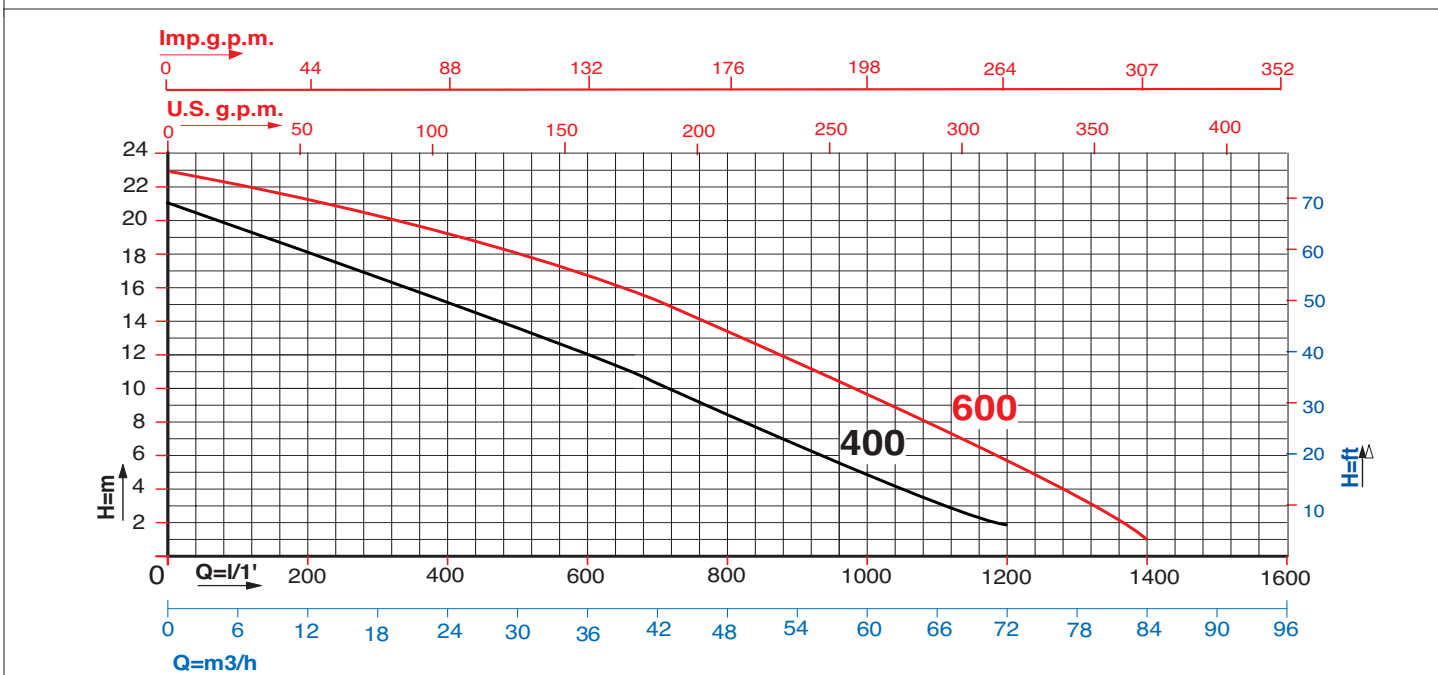
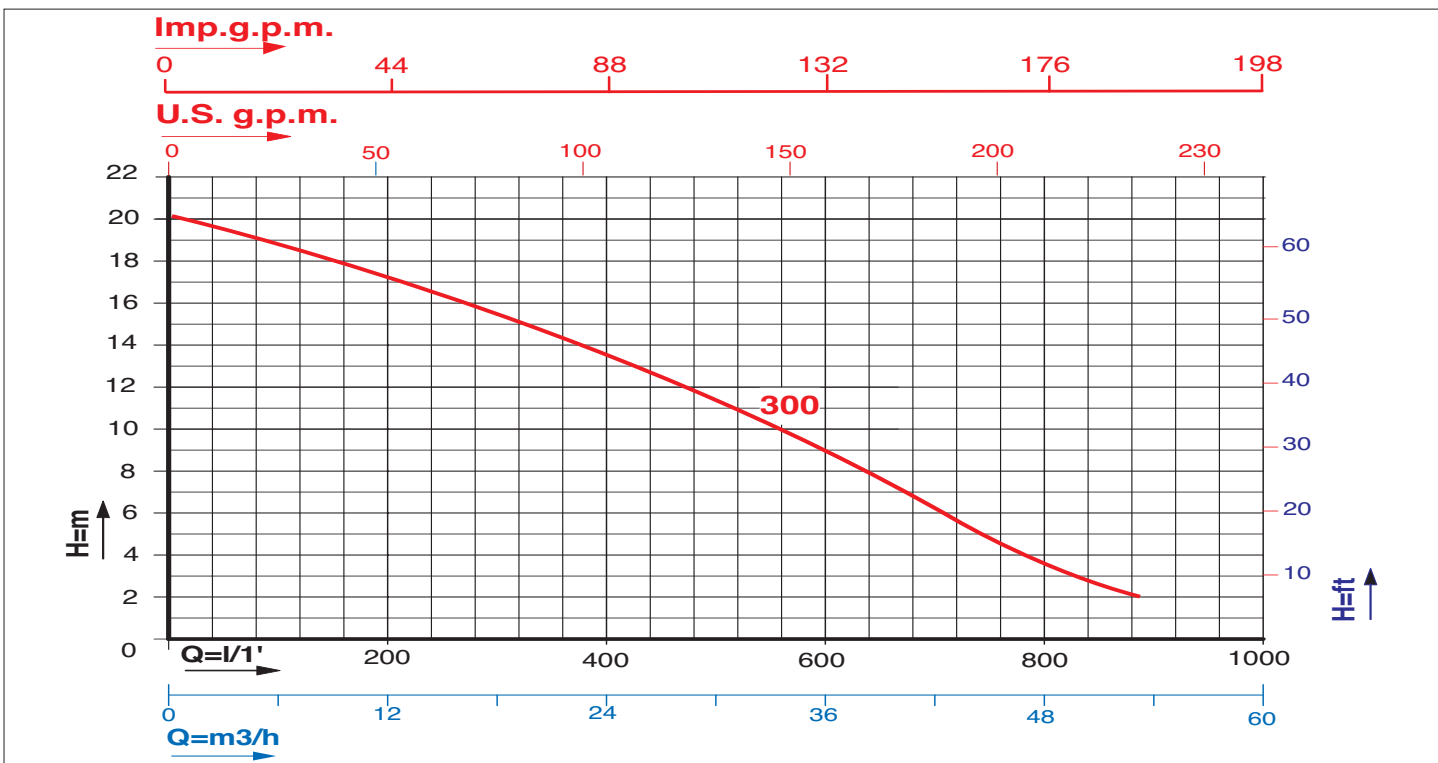

Caratteristiche di funzionamento a 2800 rpm 50Hz e 3450 rpm 60Hz - Performances at 2800 rpm 50 Hz and 3450 rpm 60 Hz

Le prestazioni valgono per liquidi con densità  $\rho = 1,0 \text{ kg/dm}^3$  ed una viscosità  $\nu = 1 \text{ mm}^2/\text{s}$  / The performance data holds true for liquids with a  $\rho = 1,0 \text{ kg/dm}^3$  density and a  $\nu = 1 \text{ mm}^2/\text{s}$  viscosity.

MODELLO MODEL	VOLTAGGIO VOLTAGE	DATI ELETTRICI / ELECTRICAL DATA						DATI IDRAULICI / HYDRAULIC DATA									
		P1 <sub>max</sub>	P2 nom.			I <sub>max</sub>	Condensatore Capacitor		m³/h	0	3	12	21	30	42	54	72
50 Hz		kW	kW	HP	Ampere	µF	VC	l/min.	0	50	200	350	500	700	900	1200	1400
KONTRACT 300 M	1 x 220-230V	4,0	2,25	3,0	20,0	80,0	450	H (m)	20,0	18,5	17,0	14,5	11,5	6,0	2,0	---	---
KONTRACT 300 T	3 x 380-440V	3,7	2,25	3,0	6,5	---	---		20,0	18,5	17,0	14,5	11,5	6,0	2,0	---	---
KONTRACT 400 T	3 x 380-440V	5,0	3,0	4,0	9,5	---	---		21,0	20,0	18,0	16,0	13,5	10,5	6,5	2,0	---
KONTRACT 600 T	3 x 380-440V	7,0	4,5	6,0	13,0	---	---		23,0	22,5	21,5	19,5	18,0	15,2	11,8	5,8	1,0

PREVALENZA TOTALE in METRI COLONNA ACQUA / TOTAL PUMP HEAD AND WATER COLUMN HEIGHT IN m.

**DIMENSIONI E PESI / SIZE AND WEIGHT DATA:**

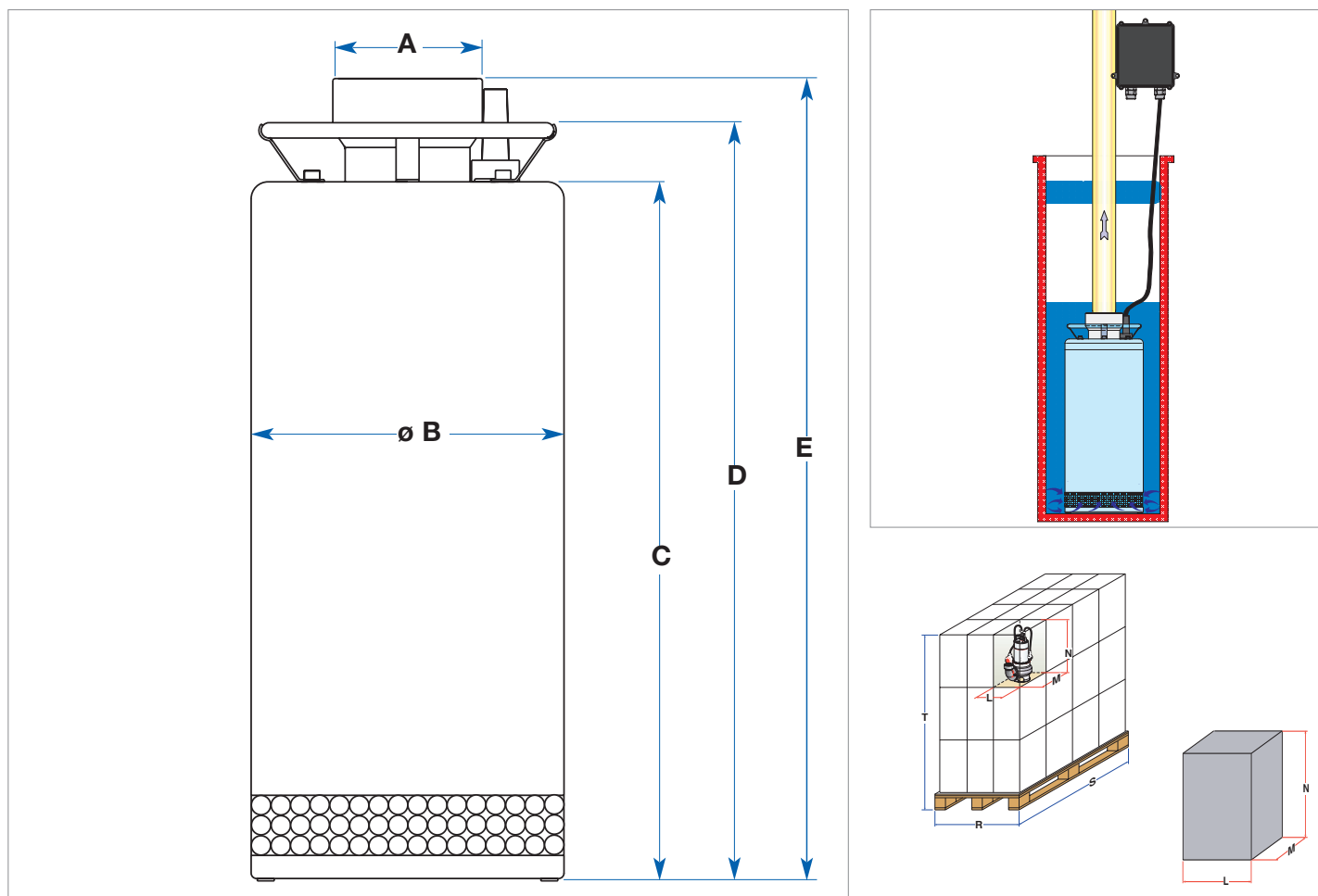

MODELLO / MODEL	DIMENSIONI POMPA in mm. / PUMP DIMENSIONS in mm.				
	A	B	C	D	E
KONTRACT 300 M	3"	203	484	539	551
KONTRACT 300 T	3"	203	484	539	551
KONTRACT 400 T	3"	203	484	539	551
KONTRACT 600 T	3"	203	484	539	551

MODELLO / MODEL	DIMENSIONI SCATOLA / PACKING DIMENSIONS				DIMENSIONI PALLET / PALLET DIMENSIONS				
	L mm.	M mm.	N mm.	Peso / Weight Kg.	R mm.	S mm.	T mm.	nr. scatole/cartons	Peso / Weight Kg.
KONTRACT 300 M	580	400	260	38,0	800	1200	900	12	481
KONTRACT 300 T	580	400	260	38,0	800	1200	900	12	481
KONTRACT 400 T	580	400	260	38,0	800	1200	900	12	481
KONTRACT 600 T	580	400	260	43,0	800	1200	900	12	541

# SPRING



**ELETTROPOMPE SOMMERSIBILI PER FONTANE E SVUOTAMENTO DI PISCINE  
SUBMERSIBLE ELECTRIC PUMPS FOR FOUNTAINS AND SWIMMING POOLS EMPTYING OPERATIONS**

**SERVIZIO CONTINUO ALTERNATO - ALTERNATED CONTINUE SERVICE**

**PREVALENZA** ..... : 8,0 mt. ÷ 16,5 mt.  
**PORTATA** ..... : 9,0 m<sup>3</sup>/h ÷ 24,0 m<sup>3</sup>/h  
**POTENZA NOMINALE** : 0,25 kW (0,33HP) ÷ 1,1kW (1,5HP)

**PUMP HEAD** ..... : 8,0 mt ÷ 16,5 mt  
**DELIVERY** ..... : 9,0 m<sup>3</sup>/h ÷ 24,0 m<sup>3</sup>/h  
**RATED HORSEPOWER** : 0,25 kW (0,33HP) ÷ 1,1 kW (1,5HP)

## **APPLICAZIONI**

- SVUOTAMENTO DI PISCINE.
- GIOCHI D'ACQUA.

## **APPLICATIONS**

- SWIMMING POOLS EMPTYING OPERATIONS.
- WATER-PLAY.

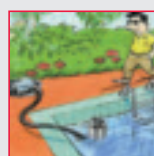
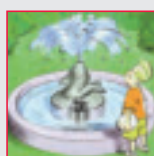
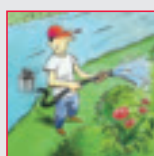

**AV ARVEN**



**CARATTERISTICHE DI COSTRUZIONE**

- ELETTOPOMPA A DOPPIA CAMERA (MOTORE, TENUTA MECCANICA).
  - MOTORE A BAGNO D'OLIO (BIODEGRADABILE E DIELETTRICO) PER RAFFREDDAMENTO E LUBRIFICAZIONE CUSCINETTI.
  - ANELLO DI TENUTA LATO MOTORE.
  - TENUTA MECCANICA A BAGNO D'OLIO.
  - IMMERSIONE MASSIMA: mt. 5.
  - GRADO DI PROTEZIONE IP 68.
  - CLASSE DI ISOLAMENTO: F.
  - TEMPERATURA MAX. LIQUIDO POMPATO: 35°C.
  - VERSIONI: Monofase: 220-277V/50Hz e 220-277V/60 Hz con protettore termico incorporato e condensatore permanentemente inserito.  
Trifase: 220-277V/50Hz o 380-480V/50Hz e 220-277V/60Hz o 380-480V/60Hz con protezione da sovraccarico a cura dell'utente.
  - POTENZA MOTORE:  
Da 0,25 kW (0,33 Hp) a 0,45 kW (0,6Hp) solo versioni monofase.  
Da 0,6 kW (0,8 Hp) a 1,1 kW (1,5Hp) versioni monofase e trifase.
  - VERSIONI MONOFASI AUTOMATICHE CON GALLEGGIANTE O MANUALI SENZA GALLEGGIANTE.
  - CAVO STANDARD:  
Monofase: 10 metri H07RN-F per versione normale (aut.-man).  
Trifase: 10 metri H07RN-F.
- SPECIALI VOLTAGGI E FREQUENZE A RICHIESTA.

**DESIGN ENGINEERING**

- DOUBLE CHAMBER ELECTRIC PUMP (MOTOR, MECHANICAL SEAL).
  - OIL BATH MOTOR (BIODEGRADABLE AND DIELECTRIC) FOR COOLING AND BEARING LUBRICATION.
  - SEALING RING - ENGINE FACE.
  - OIL BATH MECHANICAL SEALS.
  - PERMISSIBLE DRAUGHT OF WATER: 5 m.
  - IP 68 PROTECTION CLASS.
  - CLASS "F" INSULATION.
  - MAX. PUMPED LIQUID TEMPERATURE: 35°C.
  - VERSIONS: Single Phase: 220-277V/50 Hz or 220-277V/60 Hz with built in thermal protection and permanent capacitor.  
Three Phases : 220-277V/50 Hz or 380-480V/50Hz and 220-277V/60Hz or 380-480V/60Hz with overload protection care of the User.
  - MOTOR POWER:  
From 0,25 kW (0,33 HP) to 0,45 kW (0,6 HP) only single phase versions.  
From 0,6 kW (0,8 HP) to 1,1 kW (1,5HP) single phase and three phase versions.
  - AUTOMATIC SINGLE PHASE VERSIONS WITH FLOATER OR MANUAL SINGLE PHASE VERSIONS, WITHOUT FLOATER.
  - STANDARD CABLE FEATURES:  
Single phase: 10 metres H07RN-F for the standard version (automatic-manual).  
Three phases: 10 metres H07RN-F.
- CUSTOMISED VOLTAGE AND FREQUENCY RATING AVAILABLE ON DEMAND.

**TABELLA MATERIALI / MATERIALS TABLE:**

Pos.	Componente / Component		Materiale / Materials
A	Carcassa esterna / External housing		ACCIAIO INOX AISI 304 - DIN 1.4301 STAINLESS STEEL
B	Girante / Impeller	SPRING 80-100-150	TECNOPOLIMERO / TECNOPOLYMER
		SPRING 30-60	
C	Albero (lato pompa) / Shaft (pump side)	SPRING 30-60	ACCIAIO INOX AISI 303 DIN 1.4305 STAINLESS STEEL
		SPRING 80-100-150	ACCIAIO INOX AISI 316 DIN 1.4401 STAINLESS STEEL
D	Tenuta meccanica / Mechanical Seal	Lato motore / Motor face	SPRING 30-60: DOPPIO ANELLO DI TENUTA NBR / DOUBLE NBR SEAL RING SPRING 80-100-150: ANELLO DI TENUTA NBR / NBR SEAL RING
		Lato pompa / Pump face	SPRING 30-60: GRAFITE - CERAMICA / GRAPHITE - CERAMIC SPRING 80-100-150: GRAFITE-CARBURO DI SILICIO / GRAPHITE - SILICON CARBIDE
	E	Oring	NBR
G	Portamotore / Motor holder		ACCIAIO INOX AISI 304 - DIN 1.4301 STAINLESS STEEL
H	Carcassa motore / Motor housing		
I	Coperchio + maniglia / Cover + handle	SPRING 30-60	TECNOPOLIMERO / TECNOPOLYMER
		SPRING 80-100-150	
L	Diffusore / Diffuser		ACCIAIO INOX AISI 304 - DIN 1.4301 STAINLESS STEEL
Q	Filtro / Filter		

SPRING 30 - 60

SPRING 80 - 100 - 150



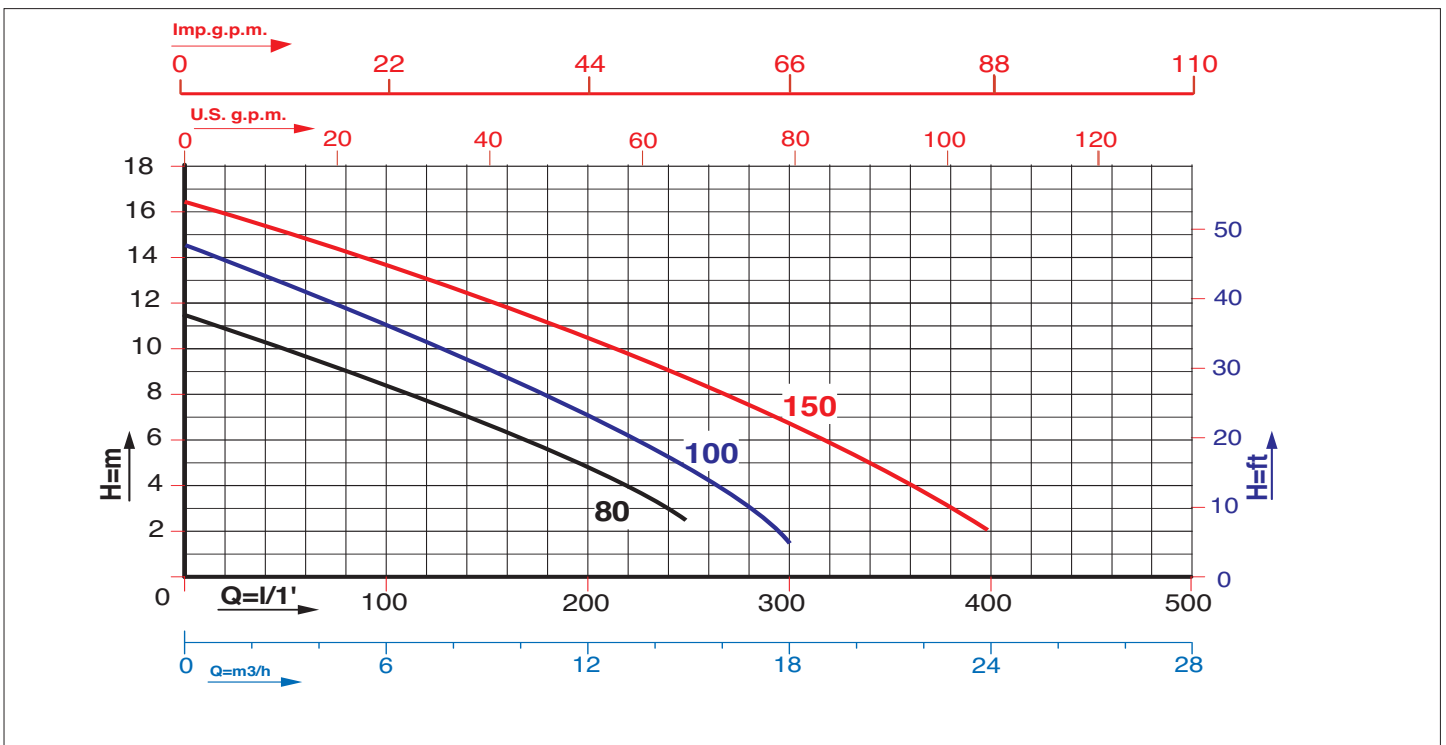
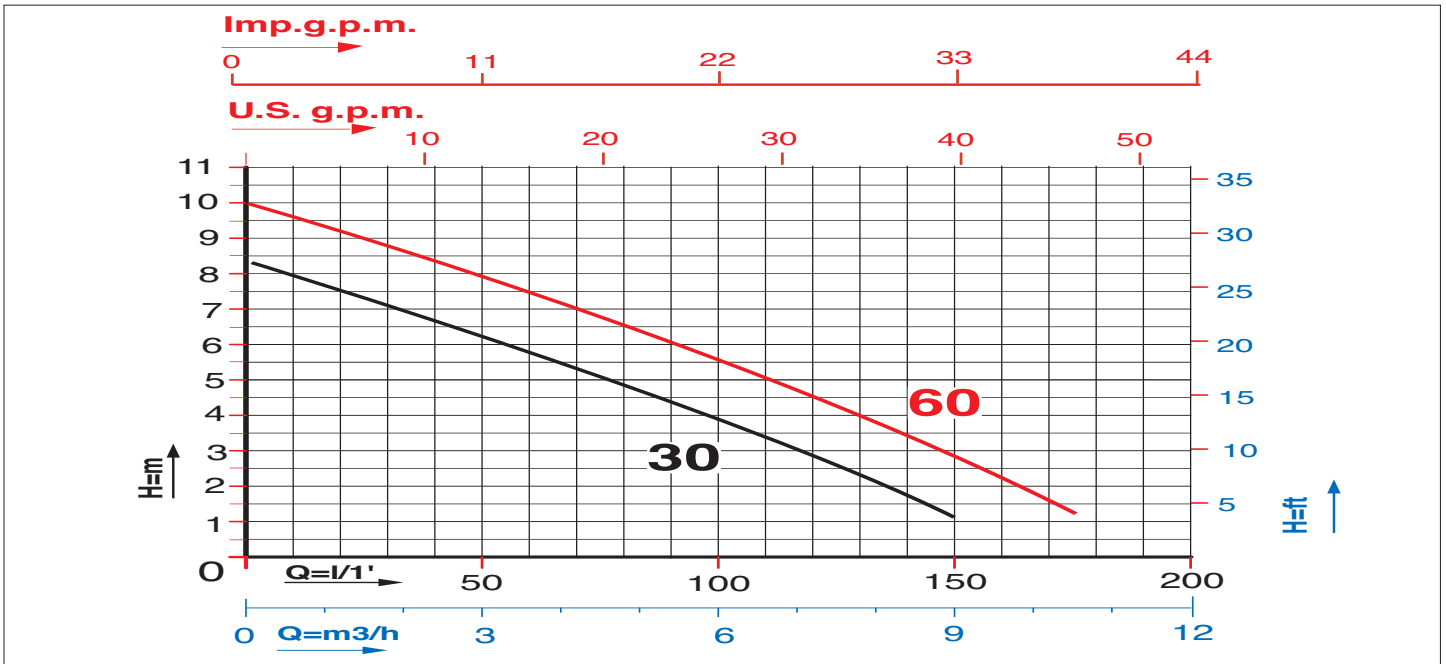

Caratteristiche di funzionamento a 2800 rpm 50Hz e 3450 rpm 60Hz - Performances at 2800 rpm 50 Hz and 3450 rpm 60 Hz

Le prestazioni valgono per liquidi con densità  $\rho = 1,0 \text{ kg/dm}^3$  ed una viscosità  $\nu = 1 \text{ mm}^2/\text{s}$  / The performance data holds true for liquids with a  $\rho = 1,0 \text{ kg/dm}^3$  density and a  $\nu = 1 \text{ mm}^2/\text{s}$  viscosity.

MODELLO MODEL	VOLTAGGIO VOLTAGE 50 Hz	DATI ELETTRICI / ELECTRICAL DATA						DATI IDRAULICI / HYDRAULIC DATA										
		P1 max kW	P2 nom. kW	I max HP	I max Ampere	Condensatore Capacitor $\mu\text{F}$	VC	m³/h	0	2,4	4,5	7,2	9	10,5	15	18	24	
SPRING 30 M	1 x 220-230V	0,5	0,25	0,33	2,2	8,0	450	PREVALENZA TOTALE in METRI COLONNA ACQUA / TOTAL PUMP HEAD AND WATER COLUMN HEIGHT IN m.	8,0	6,6	5,2	7,4	1,0					
SPRING 60 M	1 x 220-230V	0,7	0,45	0,6	3,0	10,0	450		10,0	8,0	6,8	4,3	3,0	1,2				
SPRING 60 T	3 x 380-400V	0,7	0,45	0,6	1,4	---	---		10,0	8,0	6,8	4,3	3,0	1,2				
SPRING 80 M	1 x 220-230V	1,1	0,6	0,8	4,5	16,0	450		11,5	10,5	9,5	7,5	6,2	5,0	2,0			
SPRING 80 T	3 x 380-400V	0,9	0,6	0,8	2,1	---	---		11,5	10,5	9,5	7,5	6,2	5,0	2,0			
SPRING 100 M	1 x 220-230V	1,5	0,75	1,0	6,5	20,0	450		14,5	13,5	12,0	10,5	9,5	8,0	4,0	1,5		
SPRING 100 T	3 x 380-400V	1,3	0,75	1,0	2,2	---	---		14,5	13,5	12,0	10,5	9,5	8,0	4,0	1,5		
SPRING 150 M	1 x 220-230V	2,0	1,1	1,5	10,6	30,0	450		16,5	15,5	14,5	13,0	12,1	11,2	9,0	7,0	2,0	
SPRING 150 T	3 x 380-400V	1,8	1,1	1,5	3,3	---	---		16,5	15,5	14,5	13,0	12,1	11,2	9,0	7,0	2,0	



**DIMENSIONI E PESI / SIZE AND WEIGHT DATA:**

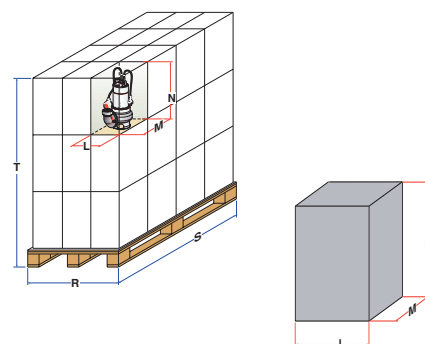
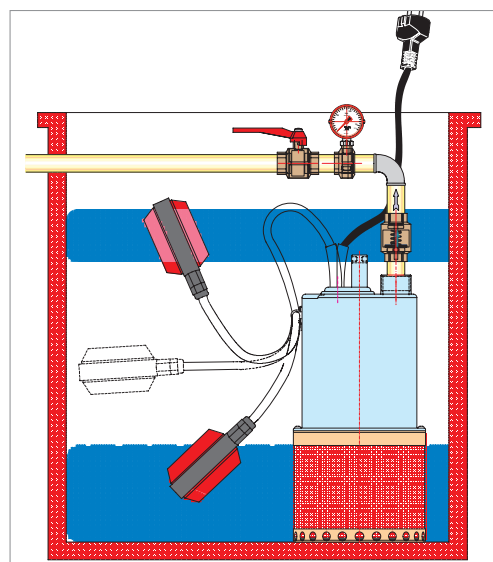
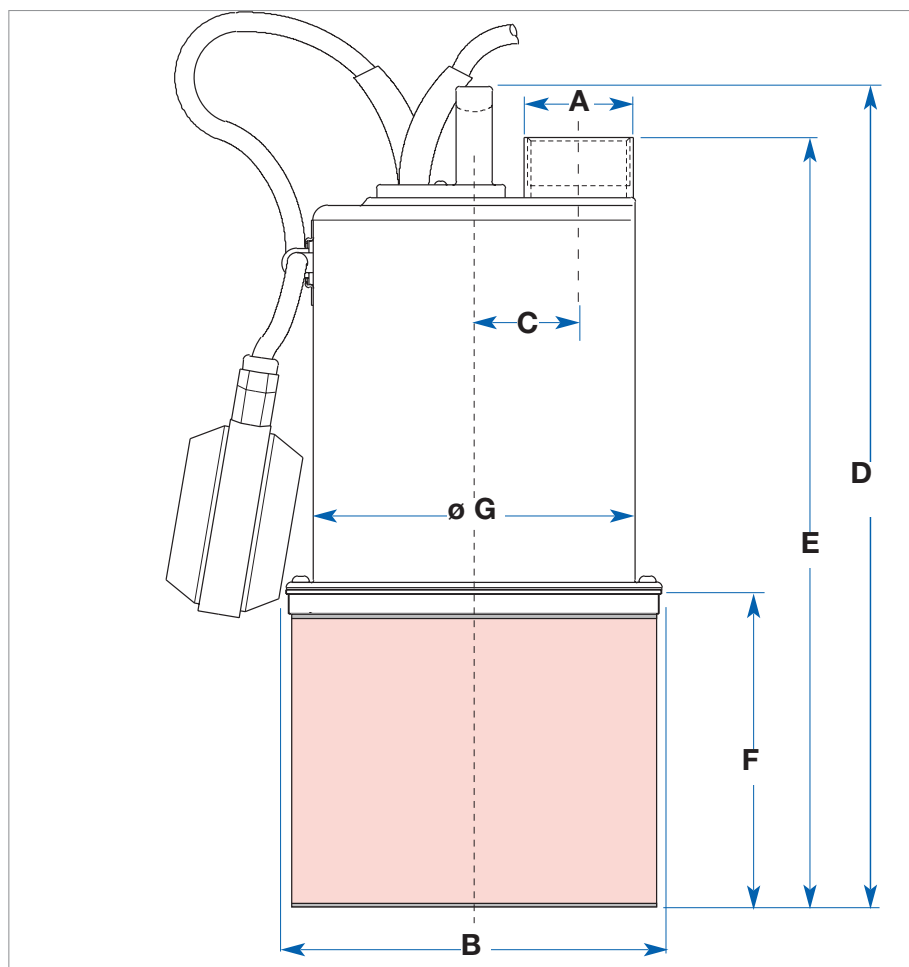

MODELLO / MODEL	DIMENSIONI POMPA in mm. / PUMP DIMENSIONS in mm.						
	A	B	C	D	E	F	G
SPRING 30 M	1" 1/4	154	41	324	303	125	132
SPRING 60 M	1" 1/4	154	41	324	303	125	132
SPRING 60 T	1" 1/4	154	41	324	303	125	132
SPRING 80 M	1" 1/2	212,4	89,7	400	369	160	202,4
SPRING 80 T	1" 1/2	212,4	89,7	400	369	160	202,4
SPRING 100 M	1" 1/2	212,4	89,7	400	369	160	202,4
SPRING 100 T	1" 1/2	212,4	89,7	400	369	160	202,4
SPRING 150 M	2"	212,4	89,7	440,2	408,2	160	202,4
SPRING 150 T	2"	212,4	89,7	440,2	408,2	160	202,4

MODELLO / MODEL	DIMENSIONI SCATOLA / PACKING DIMENSIONS				DIMENSIONI PALLET / PALLET DIMENSIONS				
	L mm.	M mm.	N mm.	Peso / Weight Kg.	R mm.	S mm.	T mm.	nr. scatole/cartons	Peso / Weight Kg.
SPRING 30 M	190	230	410	5,5	800	1200	1790	80	450
SPRING 60 M	190	230	410	6,2	800	1200	1790	80	506
SPRING 60 T	190	230	410	6,5	800	1200	1790	80	530
SPRING 80 M	260	300	530	9	800	1200	1220	24	241
SPRING 80 T	260	300	530	9	800	1200	1220	24	241
SPRING 100 M	260	300	530	11	800	1200	1220	24	289
SPRING 100 T	260	300	530	11	800	1200	1220	24	289
SPRING 150 M	260	300	530	18	800	1200	1220	24	457
SPRING 150 T	260	300	530	18	800	1200	1220	24	457

# DUMPER

70 - 80 - 100 - 140



## **ELETTROPOMPE SOMMERSIBILI DRENAGGIO PER ACQUE SPORCHE SUBMERSIBLE ELECTRIC PUMPS FOR FOUL WASTEWATER DRAINAGE**

**PREVALENZA** ..... : 10,5 mt. ÷ 19,5 mt.  
**PORTATA** ..... : 12,0 m<sup>3</sup>/h ÷ 24,0 m<sup>3</sup>/h  
**POTENZA NOMINALE** : 0,5 kW (0,7HP) ÷ 1,1 kW (1,5HP)

**PUMP HEAD** ..... : 10,5 mt ÷ 19,5 mt  
**DELIVERY** ..... : 12,0 m<sup>3</sup>/h ÷ 24,0 m<sup>3</sup>/h  
**RATED HORSEPOWER** : 0,5 kW (0,7HP) ÷ 1,1 kW (1,5 HP)

### **APPLICAZIONI**

- SVUOTAMENTO DI CANTINE, AUTORIMESSE, SCANTINATI.
- SVUOTAMENTO DI PISCINE VASCHE IN GENERE E SERBATOI.
- SVUOTAMENTO DA ACQUE PIOVANE, D'INFILTRAZIONE, DI SCARICO DI POZZETTI O VASCHE DI RACCOLTA.
- IRRIGAZIONE ORTI E GIARDINI

### **APPLICATIONS**

- CELLAR, GARAGE AND BASEMENT PUMP OUT.
- SWIMMING POOLS, ALL SORTS OF VATS, TANKS AND RESERVOIR PUMP OUT.
- RAIN, SEEPAGE, SUMP PIT AND CATCH TANK WATER PUMP OUT.
- GARDEN AND VEGETABLE-GARDEN IRRIGATION.

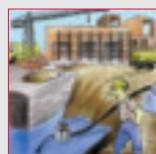
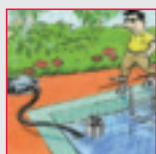
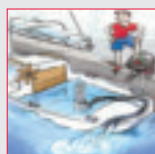

**AV ARVEN**

**CARATTERISTICHE DI COSTRUZIONE**

- ELETTOPOMPA A DOPPIA CAMERA (MOTORE, TENUTA MECCANICA).
- MOTORE A BAGNO D'OLIO (BIODEGRADABILE E DIELETTRICO) PER RAFFREDDAMENTO E LUBRIFICAZIONE CUSCINETTI.
- ANELLO DI TENUTA LATO MOTORE.
- TENUTA MECCANICA A BAGNO D'OLIO.
- IMMERSIONE MASSIMA: mt. 5.
- GRADO DI PROTEZIONE IP 68.
- CLASSE DI ISOLAMENTO: F.
- TEMPERATURA MAX. LIQUIDO POMPATO:  
25°C con pompa PARZIALMENTE immersa.  
35°C con pompa TOTALMENTE immersa.
- PASSAGGIO LIBERO: 8 mm.
- VERSIONI: Monofase: 220-277V/50Hz o 220-277V/60Hz con protettore termico incorporato e condensatore permanentemente inserito.  
Trifase: 220-277V/50Hz o 380-480V/50 Hz e 220-277V/60Hz o 380-480V/60Hz con protezione da sovraccarico a cura dell'utente.
- POTENZA MOTORE:  
da 0,7 a 1,5 Hp versioni monofase e trifase.
- VERSIONI MONOFASI AUTOMATICHE SOLO FINO A 1,5HP
- CAVO STANDARD:  
Monofase: 10 metri H07RN-F per versione normale (AUT.MAN.).  
5 metri H07RN-F (solo DUMPER 70).  
Trifase: 10 metri H07RN-F.

SPECIALI VOLTAGGI E FREQUENZE A RICHIESTA.

**DESIGN ENGINEERING**

- DOUBLE CHAMBER ELECTRIC PUMP (MOTOR, MECHANICAL SEAL).
- OIL BATH MOTOR (BIODEGRADABLE AND DIELECTRIC) FOR COOLING AND BEARING LUBRICATION.
- SEALING RING - ENGINE FACE.
- Oil bath MECHANICAL SEALS.
- PERMISSIBLE DRAUGHT OF WATER: 5 m.
- IP 68 PROTECTION CLASS.
- CLASS "F" INSULATION.
- MAX. PUMPED LIQUID TEMPERATURE:  
25°C with PARTIALLY submerged pump.  
35°C with TOTALLY submerged pump.
- BY PASS SECTION: 8 mm.
- VERSIONS: Single Phase: 220-277V/50 Hz or 220-277V/60Hz with built in thermal protection and permanent capacitor.  
Three Phases: 220-277V/50Hz or 380-480V/50Hz and 220-277V/60Hz or 380-480V/60 Hz with overload protection care of the User.
- MOTOR POWER:  
From 0,7 to 1,5HP single phase and three phase versions.
- AUTOMATIC SINGLE PHASE VERSIONS up to only 1,5HP.
- STANDARD CABLE FEATURES:  
Single phase: 10 metres H07RN-F for the standard version (automatic-manual).  
5 metres H07RN-F (only DUMPER 70).  
Three phases: 10 metres H07RN-F.

CUSTOMISED VOLTAGE AND FREQUENCY RATING AVAILABLE ON DEMAND.

**TABELLA MATERIALI / MATERIALS TABLE:**

Pos.	Componente / Component	Materiale / Materials
A	Carcassa esterna / External housing	ACCIAIO INOX AISI 304 - DIN 1.4301 STAINLESS STEEL
B	Girante / Impeller	DUMPER 70-80-100
		DUMPER 140
C	Albero (lato pompa) / Shaft (pump side)	ACCIAIO INOX AISI 316 DIN 1.4401 STAINLESS STEEL
D	Tenuta meccanica / Mechanical Seal	Lato motore / Motor face
		Lato pompa / Pump face
E	Oring	NBR
I	Coperchio / Cover	ACCIAIO INOX AISI 304 - DIN 1.4301 STAINLESS STEEL
N	Base d'aspirazione / Suction base	
L	Diffusore / Diffuser	
P	Corpo pompa / Pump body	GHISA (G.20) CAST IRON

**DUMPER 70 - 80 - 100**

**DUMPER 140**



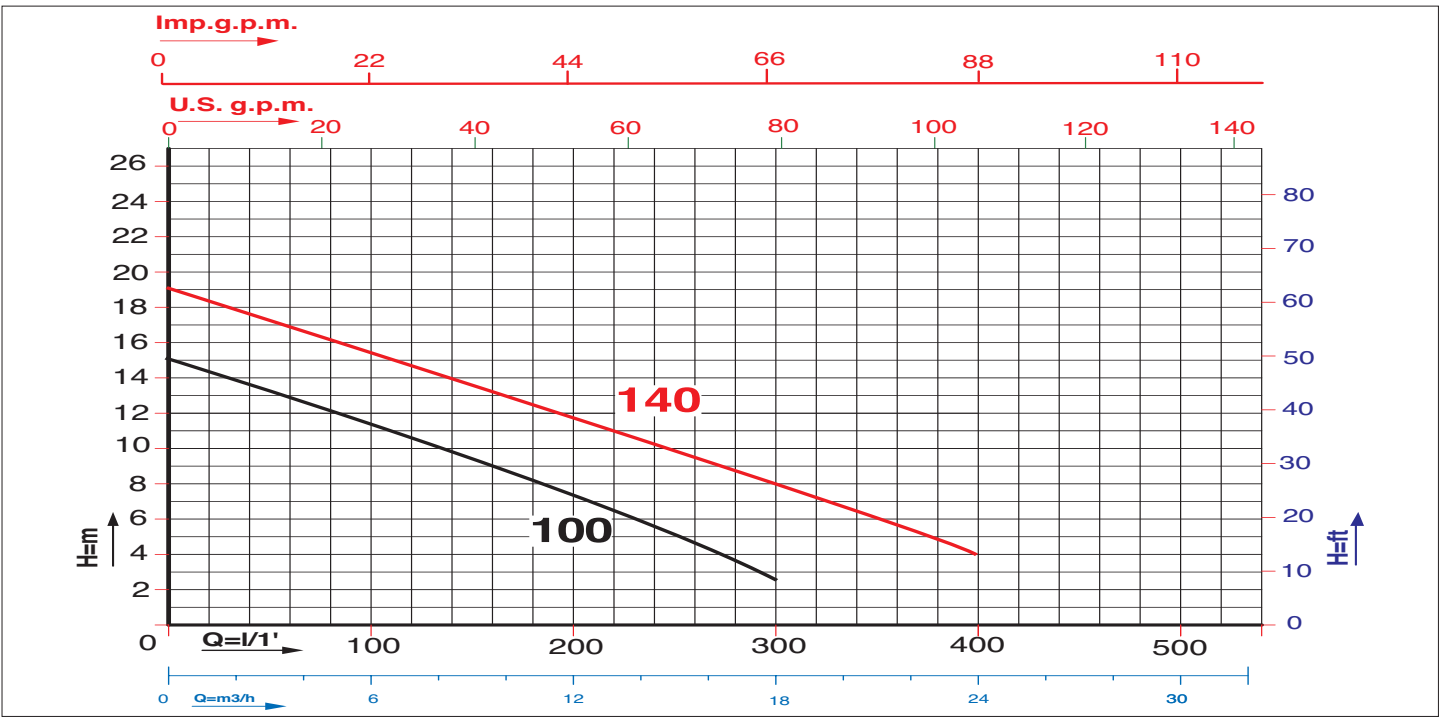
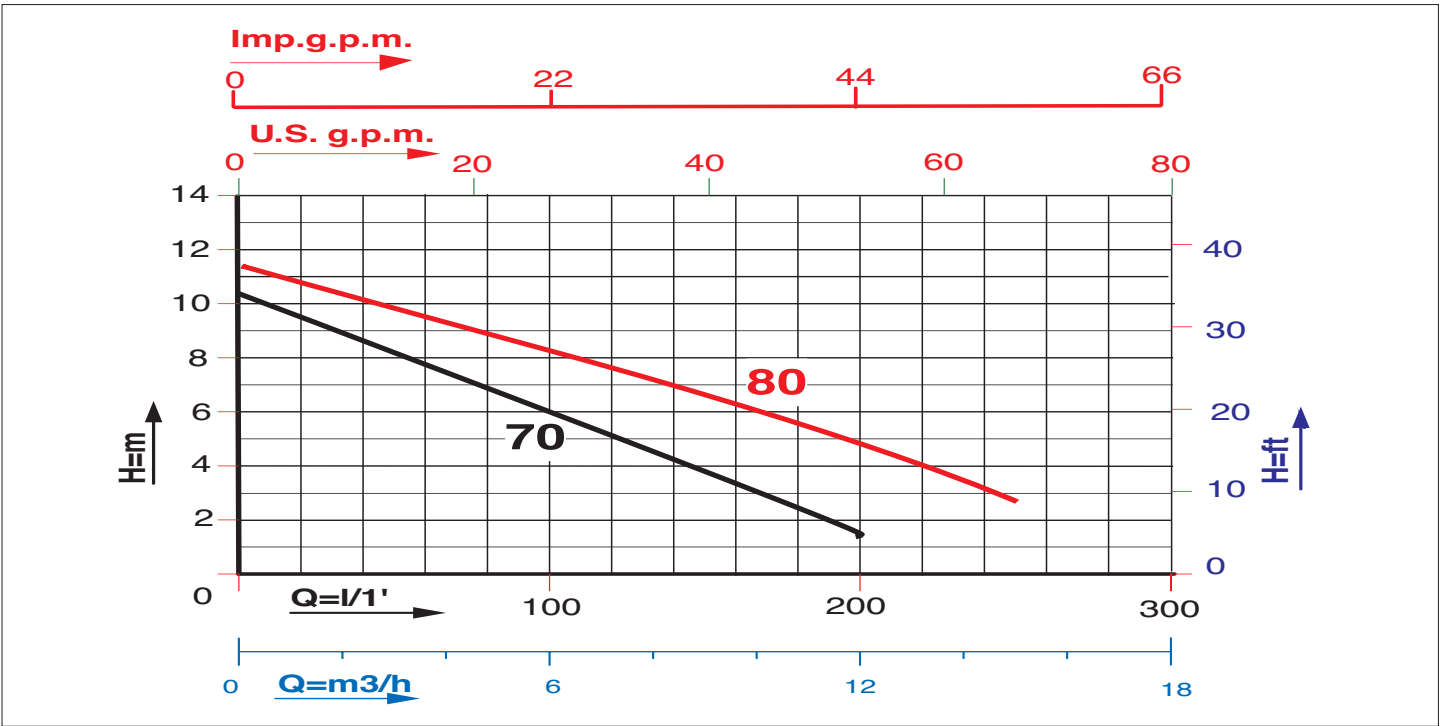

Caratteristiche di funzionamento a 2800 rpm 50Hz e 3450 rpm 60Hz - Performances at 2800 rpm 50 Hz and 3450 rpm 60 Hz  
 Le prestazioni valgono per liquidi con densità  $\rho = 1,0 \text{ kg/dm}^3$  ed una viscosità  $\nu = 1 \text{ mm}^2/\text{s}$  / The performance data holds true for liquids with a  $\rho = 1,0 \text{ kg/dm}^3$  density and a  $\nu = 1 \text{ mm}^2/\text{s}$  viscosity.

MODELLO MODEL	VOLTAGGIO VOLTAGE	DATI ELETTRICI / ELECTRICAL DATA						DATI IDRAULICI / HYDRAULIC DATA									
		P1max kW	P2 nom. kW	I max HP	I max Ampere	Condensatore Capacitor $\mu\text{F}$	VC	m³/h	0	1,5	3	6	9	12	15	18	24
DUMPER 70 M	1 x 220-230V	0,9	0,5	0,7	4,5	14,5	450	H (m)	0	25	50	100	150	200	250	300	400
DUMPER 80 M	1 x 220-230V	1,1	0,6	0,8	4,5	16,0	450		10,5	9,0	7,8	6,0	3,4	1,6	---	---	---
DUMPER 80 T	3 x 380-400V	1,0	0,6	0,8	2,1	---	---		11,5	10,3	9,5	8,2	6,9	5,2	2,6	---	---
DUMPER 100 M	1 x 220-230V	1,3	0,75	1,0	6,5	20,0	450		11,5	10,3	9,5	8,2	6,9	5,2	2,6	---	---
DUMPER 100 T	3 x 380-400V	1,1	0,75	1,0	2,6	---	---		15,0	14,0	12,8	11,2	9,2	7,4	5,2	2,6	---
DUMPER 140 M	1 x 220-230V	2,0	1,1	1,5	9,0	30,0	450		15,0	14,0	12,8	11,2	9,2	7,4	5,2	2,6	---
DUMPER 140 T	3 x 380-400V	1,7	1,1	1,5	3,0	---	---		19,5	19,0	18,5	17,5	16,0	14,0	11,8	9,2	4,0
									19,5	19,0	18,5	17,5	16,0	14,0	11,8	9,2	4,0

PREVALENZA TOTALE IN METRI COLONNA ACQUA / TOTAL PUMP HEAD AND WATER COLUMN HEIGHT IN M.

**DIMENSIONI E PESI / SIZE AND WEIGHT DATA:**

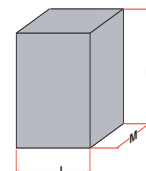
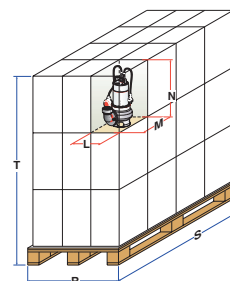
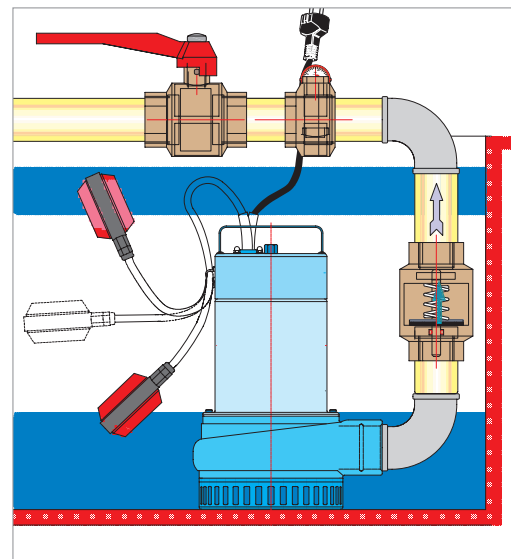
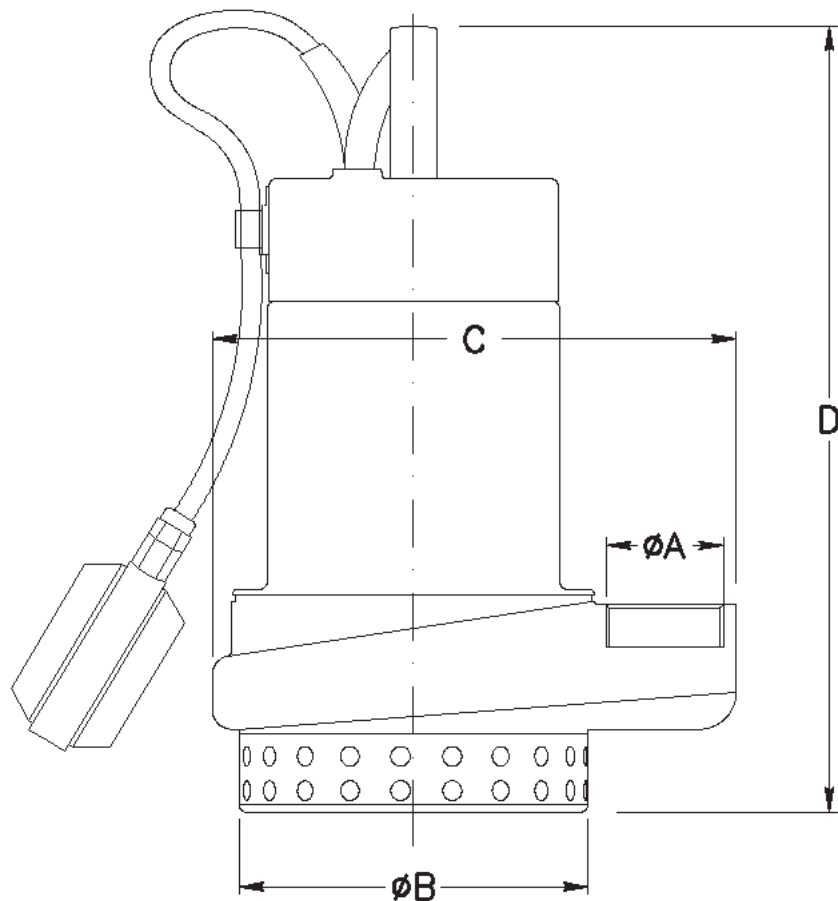

MODELLO / MODEL	DIMENSIONI POMPA in mm / PUMP DIMENSIONS in mm.			
	A	B	C	D
DUMPER 70 M	1" 1/2	190	213,5	300
DUMPER 80 M	1" 1/2	190	213,5	300
DUMPER 80 T	1" 1/2	190	213,5	300
DUMPER 100 M	1" 1/2	190	213,5	300
DUMPER 100 T	1" 1/2	190	213,5	300
DUMPER 140 M	1" 1/2	190	213,5	344
DUMPER 140 T	1" 1/2	190	213,5	344

MODELLO / MODEL	DIMENSIONI SCATOLA / PACKING DIMENSIONS				DIMENSIONI PALLET / PALLET DIMENSIONS				
	L mm.	M mm.	N mm.	Peso / Weight Kg.	R mm.	S mm.	T mm.	nr. scatole/cartons	Peso / Weight Kg.
DUMPER 70 M	190	220	320	13,0	800	1200	1130	60	745
DUMPER 80 M	190	220	320	13,0	800	1200	1130	60	805
DUMPER 80 T	190	220	320	13,0	800	1200	1130	60	805
DUMPER 100 M	190	220	320	13,5	800	1200	1130	60	835
DUMPER 100 T	190	220	320	13,5	800	1200	1130	60	835
DUMPER 140 M	260	320	340	18,2	800	1200	1400	36	670
DUMPER 140 T	260	320	340	18,2	800	1200	1400	36	670



# DUMPER

150 - 200 - 300



## **ELETTROPOMPE SOMMERSIBILI DRENAGGIO PER ACQUE SPORCHE SUBMERSIBLE ELECTRIC PUMPS FOR FOUL WASTEWATER DRAINAGE**

**PREVALENZA** ..... : 21,0 mt. ÷ 26,5 mt.  
**PORTATA** ..... : 21,0 m<sup>3</sup>/h ÷ 30,0 m<sup>3</sup>/h  
**POTENZA NOMINALE** : 1,5 kW (2HP) ÷ 2,25 kW (3HP)

**PUMP HEAD** ..... : 21,0 mt. ÷ 26,5 mt  
**DELIVERY** ..... : 21,0 m<sup>3</sup>/h ÷ 30,0 m<sup>3</sup>/h  
**RATED HORSEPOWER** : 1,5 kW (2,0HP) ÷ 2,25 kW (3,0HP)

### **APPLICAZIONI**

- SVUOTAMENTO DI CANTINE, AUTORIMESSE, SCANTINATI.
- SVUOTAMENTO DI PISCINE VASCHE IN GENERE E SERBATOI.
- SVUOTAMENTO DA ACQUE PIOVANE, D'INFILTRAZIONE, DI SCARICO DI POZZETTI O VASCHE DI RACCOLTA.
- IRRIGAZIONE ORTI E GIARDINI.

### **APPLICATIONS**

- CELLAR, GARAGE AND BASEMENT PUMP OUT.
- SWIMMING POOLS, ALL SORTS OF VATS, TANKS AND RESERVOIR PUMP OUT.
- RAIN, SEEPAGE, SUMP PIT AND CATCH TANK WATER PUMP OUT.
- GARDEN AND VEGETABLE-GARDEN IRRIGATION.

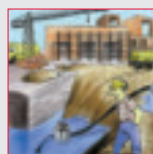
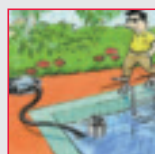
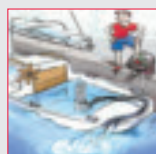

**AV ARVEN**

**CARATTERISTICHE DI COSTRUZIONE**

- ELETTOPOMPA A DOPPIA CAMERA (MOTORE, TENUTA MECCANICA).
  - MOTORE A BAGNO D'OLIO (BIODEGRADABILE E DIELETTRICO) PER RAFFREDDAMENTO E LUBRIFICAZIONE CUSCINETTI.
  - ANELLO DI TENUTA LATO MOTORE.
  - TENUTA MECCANICA A BAGNO D'OLIO.
  - DOPPIA TENUTA MECCANICA: LATO MOTORE A BAGNO D'OLIO LATO POMPA BAGNO D'ACQUA
  - IMMERSIONE MASSIMA: mt. 5.
  - GRADO DI PROTEZIONE IP 68.
  - CLASSE DI ISOLAMENTO: F.
  - TEMPERATURA MAX. LIQUIDO POMPATO:  
25°C con pompa PARZIALMENTE immersa.  
35°C con pompa TOTALMENTE immersa.
  - PASSAGGIO LIBERO: 8 mm.
  - VERSIONI: Monofase: 220-277V/50Hz o 220-277V/60 Hz con protettore termico incorporato e condensatore permanentemente inserito.  
Trifase: 220-277V/50 Hz o 380-480V/50Hz e 220-277V/60Hz o 380-480V/60Hz con protezione da sovraccarico a cura dell'utente.
  - POTENZA MOTORE:  
DA 2 a 2,5 Hp versioni monofase e trifase.  
DA 3 Hp SOLO VERSIONE TRIFASE.
  - VERSIONI MONOFASI AUTOMATICHE SOLO FINO A 2,5HP.
  - CAVO STANDARD:  
Monofase: 10 metri H07RN-F per versione normale (AUT.MAN.).  
Trifase: 10 metri H07RN-F.
- SPECIALI VOLTAGGI E FREQUENZE A RICHIESTA.

**OPTIONAL:**

- SISTEMI DI DISCESA DN50 PER IMPIANTI FISSI (VEDERE PAGINA 100).

**DESIGN ENGINEERING**

- DOUBLE CHAMBER ELECTRIC PUMP (MOTOR, MECHANICAL SEAL).
  - OIL BATH MOTOR (BIODEGRADABLE AND DIELECTRIC) FOR COOLING AND BEARING LUBRICATION.
  - SEALING RING - ENGINE FACE.
  - OIL BATH MECHANICAL SEALS.
  - DOUBLE MECHANICAL SEALS: ENGINE FACE: OIL BATH. PUMP FACE: WATER BATH.
  - PERMISSIBLE DRAUGHT OF WATER: 5 m.
  - IP 68 PROTECTION CLASS.
  - CLASS "F" INSULATION.
  - MAX. PUMPED LIQUID TEMPERATURE:  
25°C with PARTIALLY submerged pump.  
35°C with tTOTALLY submerged pump.
  - BY PASS SECTION: 8 mm
  - VERSIONS: Single Phase: 220-277V/50Hz or 220-277V/60Hz with built in thermal protection and permanent capacitor.  
Three Phases : 220- 277V/50 Hz or 380-480 V/50Hz and 220 -277V/60Hz or 380-480V/60 Hz with overload protection care of the User.
  - MOTOR POWER:  
From 2,0 to 2,5 HP single phase and three phases versions.  
From 3,0 HP ONLY THREE PHASES VERSIONS.
  - AUTOMATIC SINGLE PHASE VERSIONS up to only 2,5HP
  - STANDARD CABLE FEATURES:  
Single phase: 10 metres H07RN-F for the standard version (automatic-manual)  
Three phases: 10 metres H07RN-F.
- CUSTOMISED VOLTAGE AND FREQUENCY RATING AVAILABLE ON DEMAND.

**OPTIONAL:**

- DOWN STROKE GUIDE RAIL SYSTEMS DN50 (SEE PAGE 100).

**TABELLA MATERIALI / MATERIALS TABLE:**

Pos.	Componente / Component	Materiale / Materials
A	Carcassa esterna / External motor housing	ACCIAIO INOX AISI 304 - DIN 1.4301 STAINLESS STEEL
B	Girante / Impeller	GHISA G20 / CAST IRON
C	Albero (lato pompa) / Shaft (pump side)	ACCIAIO INOX AISI 316 - DIN 1.4401 STAINLESS STEEL
D	Tenuta meccanica Mechanical seal	Lato pompa / Pump face CARBURO DI SILICIO-CERAMICA SILICON CARBIDE-CERAMIC
		Lato motore / Engine face GRAFITE-CERAMICA GRAPHITE-CERAMIC
E	O-ring	NBR
I	Coperchio / Cover	ACCIAIO INOX AISI 304 - DIN 1.4301 STAINLESS STEEL
L	Diffusore / Diffuser	
N	Base d'aspirazione / Suction base	
P	Corpo pompa / Pump body	GHISA G20 / CAST IRON

**DUMPER 150 - 200 - 300**





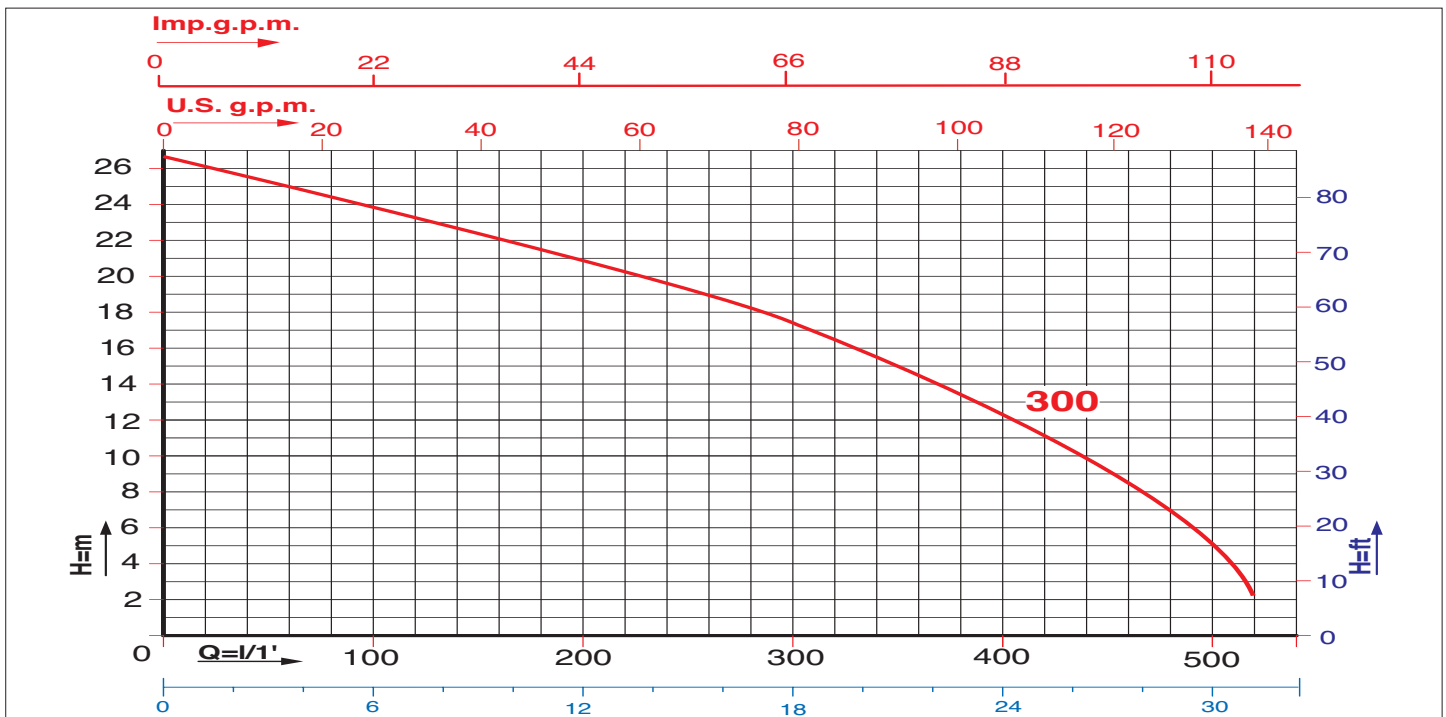
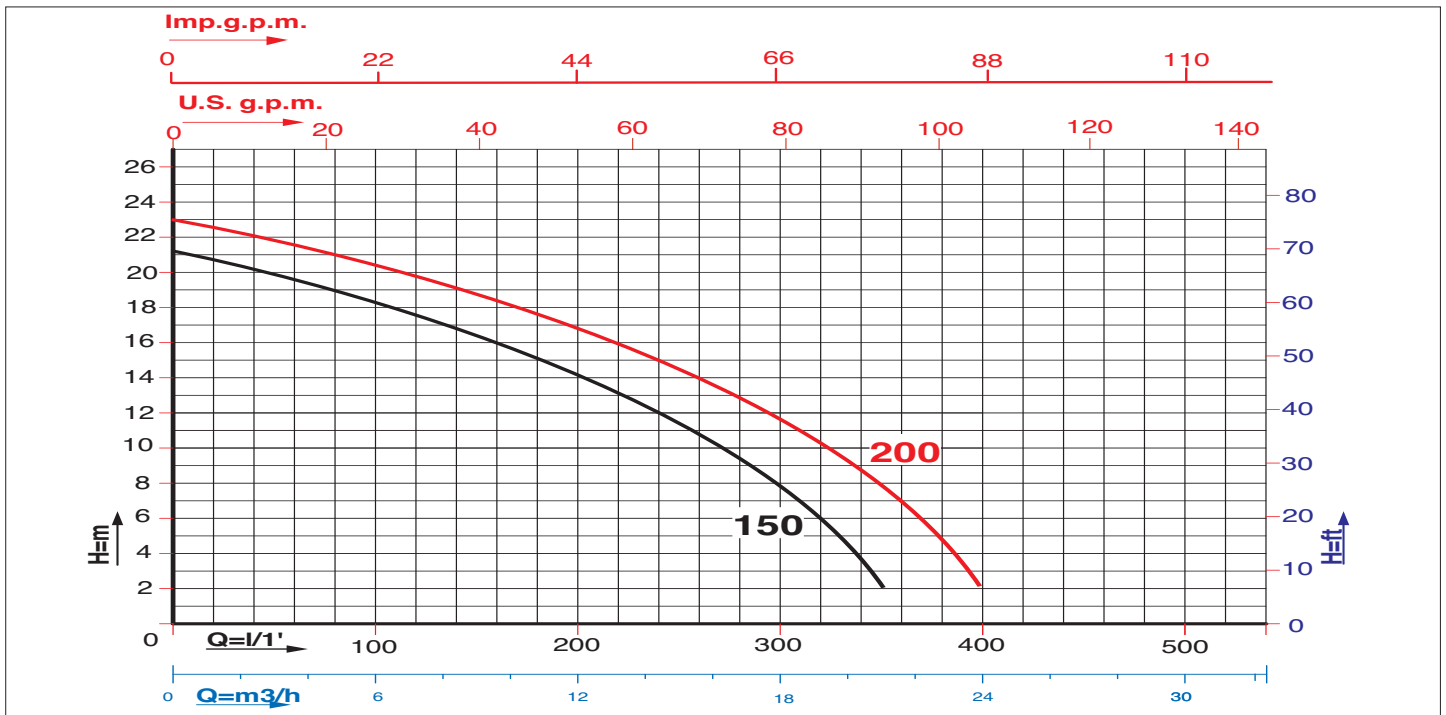

Caratteristiche di funzionamento a 2800 rpm 50Hz e 3450 rpm 60Hz - Performances at 2800 rpm 50 Hz and 3450 rpm 60 Hz  
 Le prestazioni valgono per liquidi con densità  $\rho = 1,0 \text{ kg/dm}^3$  ed una viscosità  $\nu = 1 \text{ mm}^2/\text{s}$  / The performance data holds true for liquids with a  $\rho = 1,0 \text{ kg/dm}^3$  density and a  $\nu = 1 \text{ mm}^2/\text{s}$  viscosity.

MODELLO MODEL	VOLTAGGIO VOLTAGE 50 Hz	DATI ELETTRICI / ELECTRICAL DATA					DATI IDRAULICI / HYDRAULIC DATA										
		P1max kW	P2 nom. kW	HP	I max Ampere	Condensatore Capacitor $\mu\text{F}$	VC	m <sup>3</sup> /h	0	4,5	9	12	15	18	21	24	30
DUMPER 150 M	1 x 220-230V	2,7	1,5	2	11,0	40,0	450	H (m)	0	75	150	200	250	300	350	400	500
DUMPER 150 T	3 x 380-400V	2,5	1,5	2	4,5	---	---		21,0	19,5	16,5	14,0	11,0	7,5	2,0		
DUMPER 200 M	1 x 220-230V	2,9	1,9	2,5	12,5	50,0	450		23,0	21,0	18,5	17,0	15,0	11,5	9,0	2,0	
DUMPER 200 T	3 x 380-400V	2,7	1,9	2,5	5,0	---	---		23,0	21,0	18,5	17,0	15,0	11,5	9,0	2,0	
DUMPER 300 T	3 x 380-400V	3,4	2,25	3	6	---	---		26,5	24,5	22,5	20,5	19,0	17,5	15,0	11,0	2,0

PREVALENZA TOTALE IN METRI COLONNA ACQUA / TOTAL PUMP HEAD AND WATER COLUMN HEIGHT IN m.

**DIMENSIONI E PESI / SIZE AND WEIGHT DATA:**

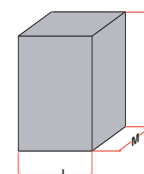
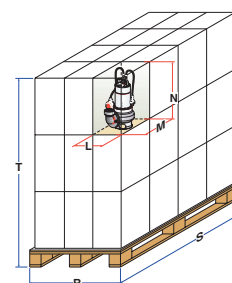
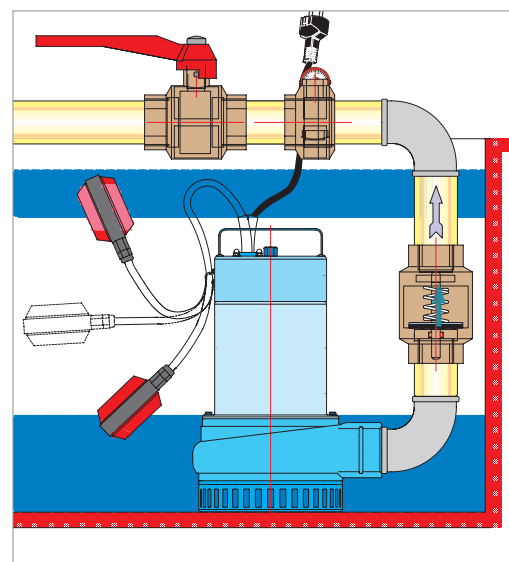
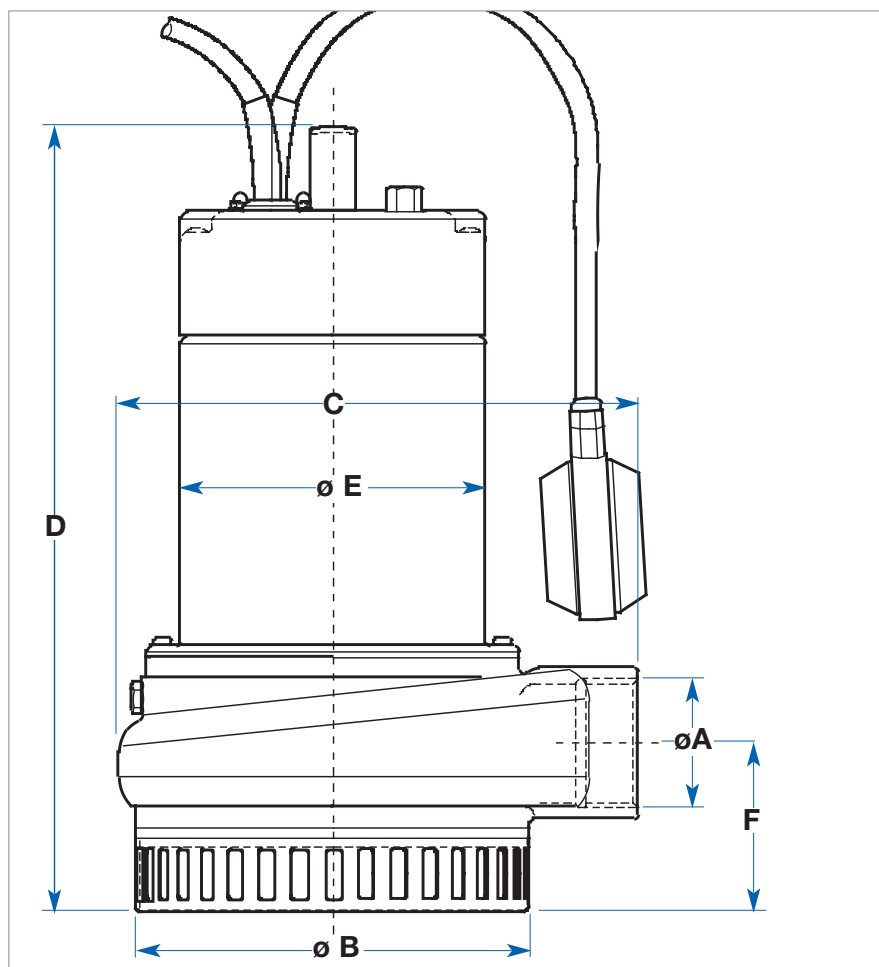

MODELLO / MODEL	DIMENSIONI POMPA in mm. / PUMP DIMENSIONS in mm.					
	A	B	C	D	E	F
DUMPER 150 M	2"	190	250	378	148	81,5
DUMPER 150 T	2"	190	250	378	148	81,5
DUMPER 200 M	2"	190	250	378	148	81,5
DUMPER 200 T	2"	190	250	378	148	81,5
DUMPER 300 T	2"	190	250	378	148	81,5

MODELLO / MODEL	DIMENSIONI SCATOLA / PACKING DIMENSIONS				DIMENSIONI PALLET / PALLET DIMENSIONS				
	L mm.	M mm.	N mm.	Peso / Weight Kg.	R mm.	S mm.	T mm.	nr. scatole/cartons	Peso / Weight Kg.
DUMPER 150 M	260	300	530	25,5	800	1200	1750	36	938
DUMPER 150 T	260	300	530	25,5	800	1200	1750	36	938
DUMPER 200 M	260	300	530	28,5	800	1200	1750	36	1046
DUMPER 200 T	260	300	530	28,5	800	1200	1750	36	1046
DUMPER 300 T	260	300	530	29,5	800	1200	1750	36	938

# TIGER



## **ELETTROPOMPE SOMMERGIBILI VORTEX E BICANALI PER ACQUE CARICHE SUBMERSIBLE VORTEX AND BICANAL ELECTRIC PUMPS FOR WASTEWATER**

**PREVALENZA** ..... : 6,5 mt. ÷ 16,0 mt.  
**PORTATA** ..... : 12,0 m<sup>3</sup>/h ÷ 42,0 m<sup>3</sup>/h  
**POTENZA NOMINALE** : 0,5 kW (0,7HP) ÷ 1,5 kW (2,0HP)  
**PASSAGGIO SOLIDI FINO A 50 mm.**

**PUMP HEAD** ..... : 6,5 mt ÷ 16,0 mt  
**DELIVERY** ..... : 12,0 m<sup>3</sup>/h ÷ 42,0 m<sup>3</sup>/h  
**RATED HORSEPOWER** : 0,5 kW (0,7HP) ÷ 1,5 kW (2,0HP)  
**SOLID MATTER BYPASS up to 50 mm.**

### **APPLICAZIONI**

- SVUOTAMENTO DI FOSSE DI DECANTAZIONE, POZZI NERI, POZZI DI RACCOLTA LIQUAMI
- POMPAGGIO DI ACQUE LURIDE ANCHE CON CORPI SOLIDI IN SOSPENSIONE
- MOVIMENTAZIONE DI ACQUE LURIDE AD USO DOMESTICO ED INDUSTRIALE

### **APPLICATIONS**

- DECANTATION PIT, SEWAGE PIT AND SLURRY COLLECTION PIT PUMP OUT
- PUMP OUT OF LAVATORY/FOUL WATER WITH POSSIBLE FLOATING SOLIDS CONTENTS
- DOMESTIC AND INDUSTRIAL LAVATORY/BLACK WATER HANDLING SYSTEMS.

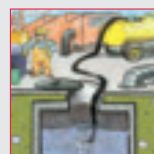
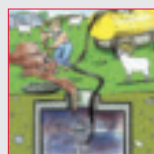
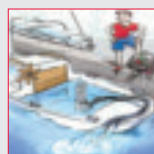
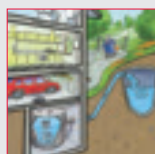

**AV ARVEN**

**CARATTERISTICHE DI COSTRUZIONE**

- ELETTOPOMPA A DOPPIA CAMERA (MOTORE, TENUTA MECCANICA).
  - MOTORE A BAGNO D'OLIO (BIODEGRADABILE E DIELETTRICO) PER RAFFREDDAMENTO E LUBRIFICAZIONE CUSCINETTI.
  - ANELLO DI TENUTA LATO MOTORE.
  - TENUTA MECCANICA A BAGNO D'OLIO.
  - IMMERSIONE MASSIMA: mt. 5 .
  - GRADO DI PROTEZIONE IP 68 .
  - CLASSE DI ISOLAMENTO: F
  - TEMPERATURA MAX. LIQUIDO POMPATO:  
25°C con pompa PARZIALMENTE immersa.  
35°C con pompa TOTALMENTE immersa
  - PASSAGGIO LIBERO: 30 mm - TIGER 70.  
35 mm - TIGER 80.  
50 mm - TIGER 100 - 150 - 200.
  - VERSIONI: Monofase: 220-277V/50Hz e 220-277V/60Hz con protettore termico incorporato e condensatore permanentemente inserito.  
Trifase: 220-277V/50Hz o 380-480V/50Hz e 220-277V/60Hz o 380-480V/60Hz con protezione da sovraccarico a cura dell'utente.
  - VERSIONI MONOFASI AUTOMATICHE CON GALLEGGIANTE O MANUALI SENZA GALLEGGIANTE.
  - CAVO STANDARD:  
Monofase: 10 metri H07RN-F per versione normale (aut.-man.)  
5 metri H07RN-F solo per versione automatica. (esclusa TIGER 150)  
5 metri H05VV-F solo per TIGER 70.  
Trifase: 10 metri H07RN-F
- SPECIALI VOLTAGGI E FREQUENZE A RICHIESTA.

**DESIGN ENGINEERING**

- DUAL CHAMBER ELECTRIC PUMP (MECHANICAL SEAL, MOTOR).
  - OIL BATH MOTOR (BIODEGRADABLE AND DIELECTRIC) FOR COOLING AND BEARING LUBRICATION.
  - SEALING RING - ENGINE FACE.
  - OIL BATH MECHANICAL SEALS.
  - PERMISSIBLE DRAUGHT OF WATER: 5 m.
  - IP 68 PROTECTION CLASS.
  - CLASS "F" INSULATION.
  - MAX. PUMPED LIQUID TEMPERATURE:  
25°C with PARTIALLY submerged pump.  
35°C with TOTALLY submerged pump.
  - BY PASS SECTION: 30 mm - TIGER 70.  
35 mm - TIGER 80.  
50 mm - TIGER 100 - 150 - 200.
  - VERSIONS: Single Phase: 220-230V/50Hz or 220-230V/60 Hz with built in thermal protection and permanent capacitor.  
Three Phases : 220-277V/50 Hz or 380-480V/50Hz and 220-277V/60Hz or 380-480V/60Hz with overload protection care of the User.
  - AUTOMATIC SINGLE PHASE VERSIONS WITH FLOATER OR MANUAL SINGLE PHASE VERSION WITHOUT FLOATER.
  - STANDARD CABLE FEATURES:  
Single Phase: 10 metres H07RN-F for the standard version (automatic-manual).  
5 metres H07RN-F only for the automatic version. (excluded TIGER 150).  
5 metres H05VV-F only for TIGER 70.  
Three Phases: 10 metres H07RN-F.
- CUSTOMISED VOLTAGE AND FREQUENCY RATING AVAILABLE ON DEMAND.

**TABELLA MATERIALI / MATERIALS TABLE:**

Pos.	Componente / Component	Materiale / Materials
A	Carcassa esterna / External housing	ACCIAIO INOX AISI 304-DIN 1.4301 STAINLESS STEEL
B	Girante / Impeller	
C	Albero (lato pompa) Shaft (pump side)	TIGER 70 ACCIAIO INOX AISI 416-DIN 1.4005 / STAINLESS STEEL
		TIGER 80-100-150 ACCIAIO INOX AISI 316-DIN 1.4401 / STAINLESS STEEL
D	Tenuta meccanica Mechanical seal	Lato pompa / Pump face GRAFITE-CERAMICA GRAPHITE-CERAMIC
		Lato motore / Motor face ANELLO DI TENUTA NBR NBR SEAL RING
E	O-ring	NBR
G	Porta motore / Motor holder	ACCIAIO INOX AISI 304-DIN 1.4301 STAINLESS STEEL
I	Coperchio / Cover	
N	Base d'appoggio / Base holder	
P	Corpo pompa / Pump body	GHISA (G20) / CAST IRON

TIGER 70

TIGER 80 - 100 - 150 - 200



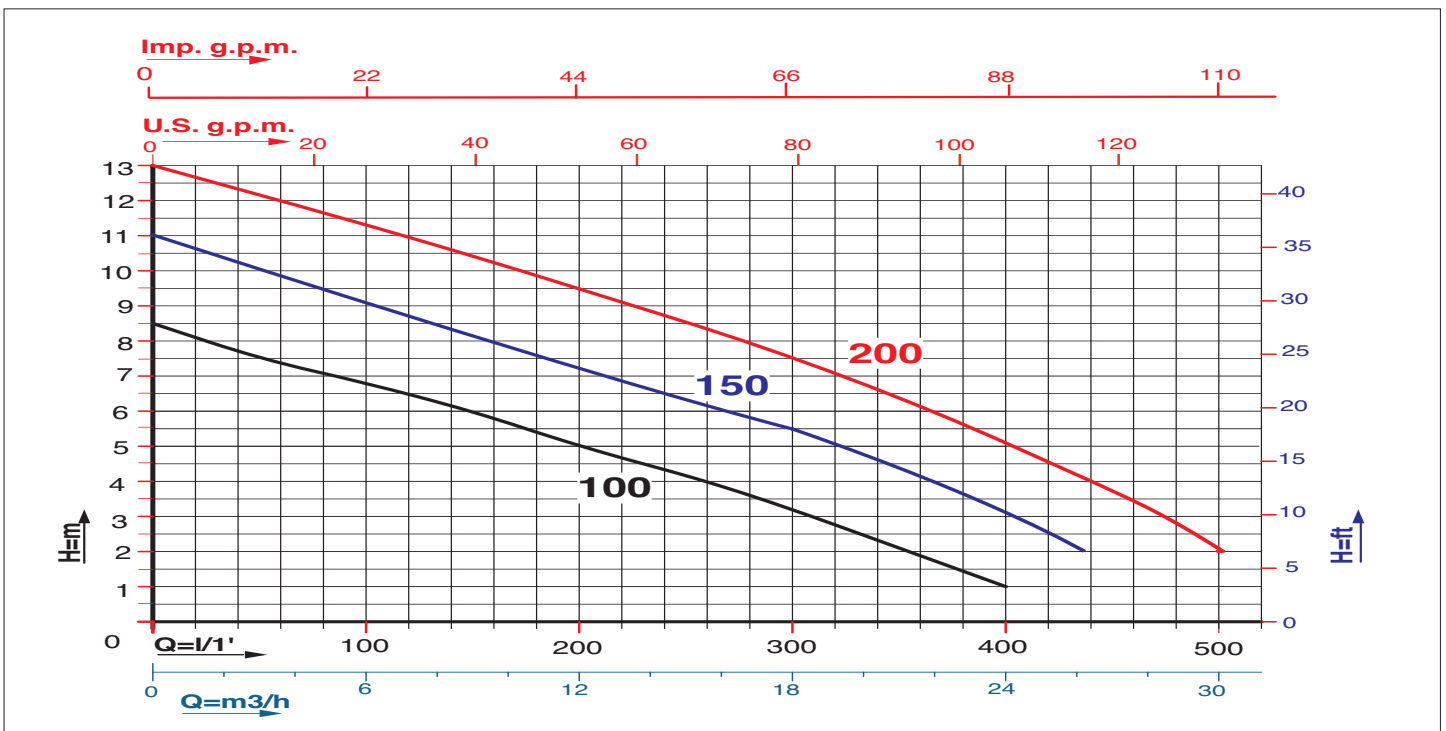
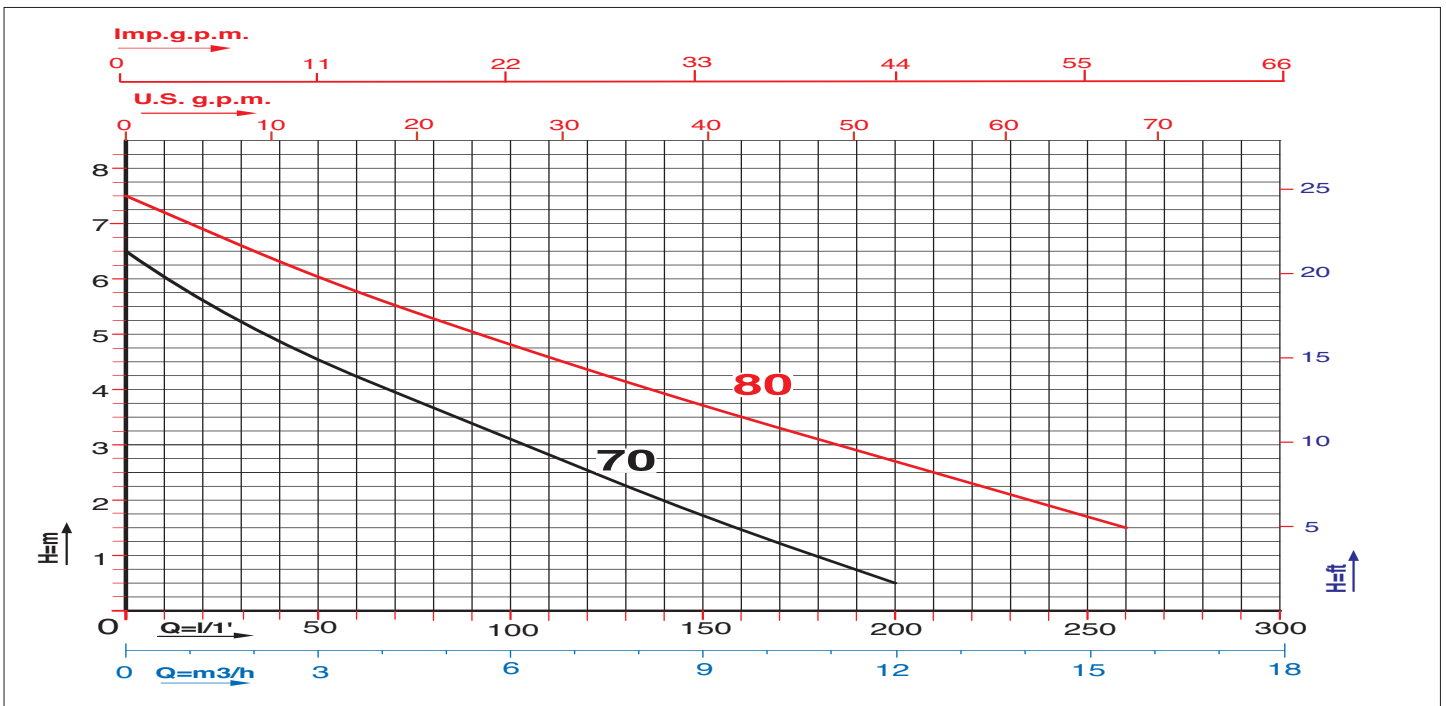

Caratteristiche di funzionamento a 2800 rpm 50Hz e 3450 rpm 60Hz - Performances at 2800 rpm 50 Hz and 3450 rpm 60 Hz  
 Le prestazioni valgono per liquidi con densità  $\rho = 1,0 \text{ kg/dm}^3$  ed una viscosità  $\nu = 1 \text{ mm}^2/\text{s}$  / The performance data holds true for liquids with a  $\rho = 1,0 \text{ kg/dm}^3$  density and a  $\nu = 1 \text{ mm}^2/\text{s}$  viscosity.

MODELLO MODEL	VOLTAGGIO VOLTAGE	DATI ELETTRICI / ELECTRICAL DATA						DATI IDRAULICI / HYDRAULIC DATA												
		P1max	P2 nom.		I max	Condensatore Capacitor		m³/h		0	3	6	9	12	15,6	18	24	27	30	
50 Hz		kW	kW	HP	Ampere	µF	VC	l/min.		0	50	100	150	200	260	300	400	450	500	
TIGER 70 M	1 x 220-230V	0,9	0,5	0,7	4,0	14,5	450	H (m)		6,5	4,5	3,1	1,7	0,5	---	---	---	---	---	
TIGER 80 M	1 x 220-230V	1,1	0,6	0,8	5,0	16,0	450			7,5	6,0	4,8	3,7	2,7	1,5	---	---	---	---	---
TIGER 80 T	3 x 380-440V	0,9	0,6	0,8	2,0	---	---			7,5	6,0	4,8	3,7	2,7	1,5	---	---	---	---	---
TIGER 100 M	1 x 220-230V	1,5	0,75	1,0	6,5	20,0	450			8,5	7,5	6,8	6,0	5,0	4,0	3,2	1,0	---	---	---
TIGER 100 T	3 x 380-440V	1,3	0,75	1,0	2,4	---	---			8,5	7,5	6,8	6,0	5,0	4,0	3,2	1,0	---	---	---
TIGER 150 M	1 x 220-230V	2,2	1,1	1,5	10,4	30,0	450			11,0	9,8	9,0	8,0	7,3	6,2	5,6	3,2	1,8	---	---
TIGER 150 T	3 x 380-440V	1,7	1,1	1,5	3,0	---	---			11,0	9,8	9,0	8,0	7,3	6,2	5,6	3,2	1,8	---	---
TIGER 200 M	1 x 220-230V	2,4	1,5	2,0	11,5	30,0	450			13,0	12,2	11,2	10,4	9,5	8,3	7,5	5,2	3,0	2,0	---
TIGER 200 T	3 x 380-440V	2,2	1,5	2,0	3,6	---	---			13,0	12,2	11,2	10,4	9,5	8,3	7,5	5,2	3,0	2,0	---

PREVALENZA TOTALE in METRI COLONNA ACQUA / TOTAL PUMP HEAD AND WATER COLUMN HEIGHT IN m.



**CARATTERISTICHE DI COSTRUZIONE**

- ELETTOPOMPA A DOPPIA CAMERA (MOTORE, TENUTA MECCANICA).
  - MOTORE A BAGNO D'OLIO (BIODEGRADABILE E DIELETTRICO) PER RAFFREDDAMENTO E LUBRIFICAZIONE CUSCINETTI.
  - ANELLO DI TENUTA LATO MOTORE.
  - TENUTA MECCANICA A BAGNO D'OLIO.
  - IMMERSIONE MASSIMA: mt. 5.
  - GRADO DI PROTEZIONE IP 68 .
  - CLASSE DI ISOLAMENTO: F.
  - TEMPERATURA MAX. LIQUIDO POMPATO:  
25°C con pompa PARZIALMENTE immersa.  
35°C con pompa TOTALMENTE immersa.
  - PASSAGGIO LIBERO: 50 mm - TIGER BC 100 - 150 - 200.
  - VERSIONI: Monofase: 220-277V/50Hz e 220-277V/60 Hz con protettore termico incorporato e condensatore permanentemente inserito.  
Trifase: 220-277V/50Hz o 380-480V/50Hz e 220-277V/60Hz o 380-480V/60Hz con protezione da sovraccarico a cura dell'utente.
  - VERSIONI MONOFASI AUTOMATICHE CON GALLEGGIANTE O MANUALI SENZA GALLEGGIANTE.
  - CAVO STANDARD:  
Monofase: 10 metri H07RN-F per versione normale (aut.-man.).  
Trifase: 10 metri H07RN-F.
- SPECIALI VOLTAGGI E FREQUENZE A RICHIESTA.

**DESIGN ENGINEERING**

- DUAL CHAMBER ELECTRIC PUMP (mechanical seal, motor).
  - OIL BATH MOTOR (BIODEGRADABLE AND DIELECTRIC) FOR COOLING AND BEARING LUBRICATION.
  - SEALING RING - ENGINE FACE.
  - OIL BATH MECHANICAL SEALS.
  - PERMISSIBLE DRAUGHT OF WATER: 5 m.
  - IP 68 PROTECTION CLASS.
  - CLASS "F" INSULATION.
  - MAX. PUMPED LIQUID TEMPERATURE:  
25°C with PARTIALLY submerged pump.  
35°C with TOTALLY submerged pump.
  - BY PASS SECTION: 50 mm - TIGER BC 100 - 150 - 200.
  - VERSIONS: Single Phase: 220-277V/50 Hz or 220-277V/60 Hz with built in thermal protection and permanent capacitor.  
Three Phases : 220-277V/50 Hz or 380-480V/50Hz and 220-277V/60Hz or 380-480V/60Hz with overload protection care of the User.
  - AUTOMATIC SINGLE PHASE VERSIONS WITH FLOATER OR MANUAL SINGLE PHASE VERSION WITHOUT FLOATER.
  - STANDARD CABLE FEATURES:  
Single Phase: 10 metres H07RN-F for the standard version (automatic-manual).  
Three Phase: 10 metres H07RN-F.
- CUSTOMISED VOLTAGE AND FREQUENCY RATING AVAILABLE ON DEMAND.

**TABELLA MATERIALI / MATERIALS TABLE:**

Pos.	Componente / Component	Materiale / Materials	
A	Carcassa esterna / External housing	ACCIAIO INOX AISI 304 DIN 1.4301 STAINLESS STEEL	
B	Girante / Impeller	GHISA (G20) CAST IRON	
C	Albero (lato pompa) / Shaft (pump side)	ACCIAIO INOX AISI 316 DIN 1.4401 STAINLESS STEEL	
D	Tenuta meccanica Mechanical seal	Lato pompa / Pump face	GRAFITE-CERAMICA GRAPHITE-CERAMIC
		Lato motore / Motor face	ANELLO DI TENUTA NBR NBR SEAL RING
E	O-ring	NBR	
G	Porta motore / Motor holder	ACCIAIO INOX AISI 304 DIN 1.4301 STAINLESS STEEL	
I	Coperchio / Cover		
N	Base d'appoggio / Base holder	ACCIAIO INOX AISI 304 DIN 1.4301 STAINLESS STEEL	
P	Corpo pompa / Pump body	GHISA (G20) CAST IRON	

**TIGER - BC 100 - 150 - 200**

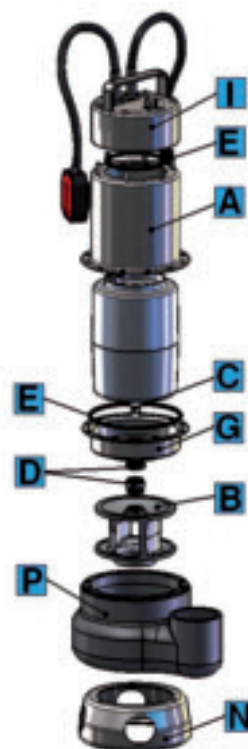



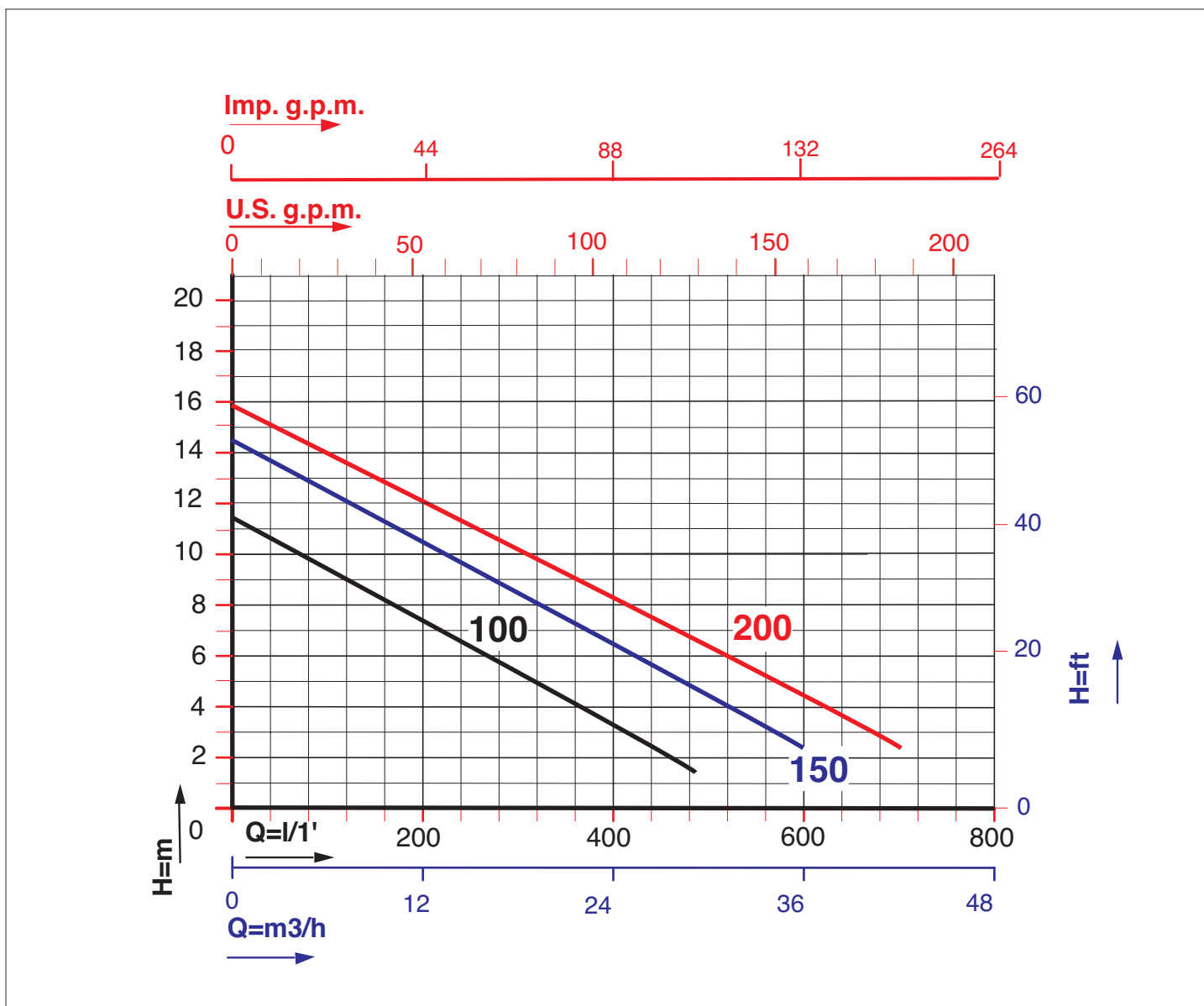

Caratteristiche di funzionamento a 2800 rpm 50Hz e 3450 rpm 60Hz - Performances at 2800 rpm 50 Hz and 3450 rpm 60 Hz  
 Le prestazioni valgono per liquidi con densità  $\rho = 1,0 \text{ kg/dm}^3$  ed una viscosità  $\nu = 1 \text{ mm}^2/\text{s}$  / The performance data holds true for liquids with a  $\rho = 1,0 \text{ kg/dm}^3$  density and a  $\nu = 1 \text{ mm}^2/\text{s}$  viscosity.

MODELLO MODEL	VOLTAGGIO VOLTAGE 50 Hz	DATI ELETTRICI / ELECTRICAL DATA						DATI IDRAULICI / HYDRAULIC DATA									
		P1 max		P2 nom.		I max	Condensatore Capacitor		m³/h								
		kW	kW	HP	Ampere		µF	VC	0	3	6	12	18	24	30	36	42
TIGER - BC 100 M	1 x 220-230V	1,5	0,75	1,0	7,0	20,0	450	H (m)	0	50	100	200	300	400	500	600	700
TIGER - BC 100 T	3 x 380-440V	1,3	0,75	1,0	3,2	---	---		11,5	10,5	9,5	7,5	5,5	3,3	1,5	---	---
TIGER - BC 150 M	1 x 220-230V	2,2	1,1	1,5	11,5	30,0	450		14,5	13,5	12,5	10,5	8,5	6,5	4,5	2,5	---
TIGER - BC 150 T	3 x 380-440V	1,7	1,1	1,5	4,5	---	---		14,5	13,5	12,5	10,5	8,5	6,5	4,5	2,5	---
TIGER - BC 200 T	3 x 380-440V	2,2	1,5	2,0	4,8	---	---		16,0	14,8	14,0	12,0	10,5	8,2	6,5	4,3	2,5

PREVALENZA TOTALE in METRI COLONNA ACQUA / TOTAL PUMP HEAD AND WATER COLUMN HEIGHT IN m.

**DIMENSIONI E PESI / SIZE AND WEIGHT DATA:**

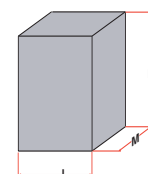
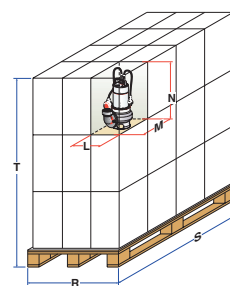
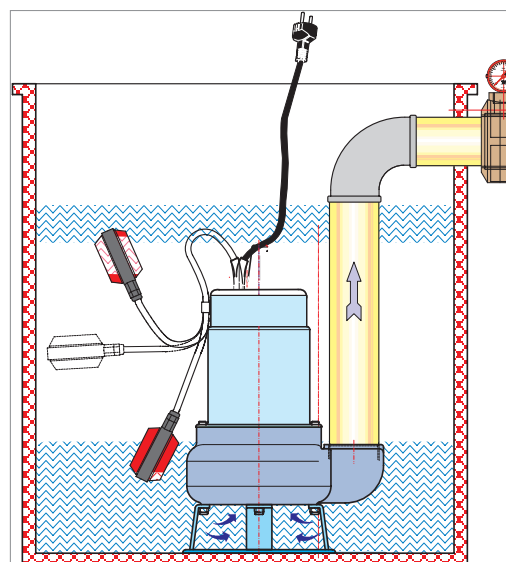
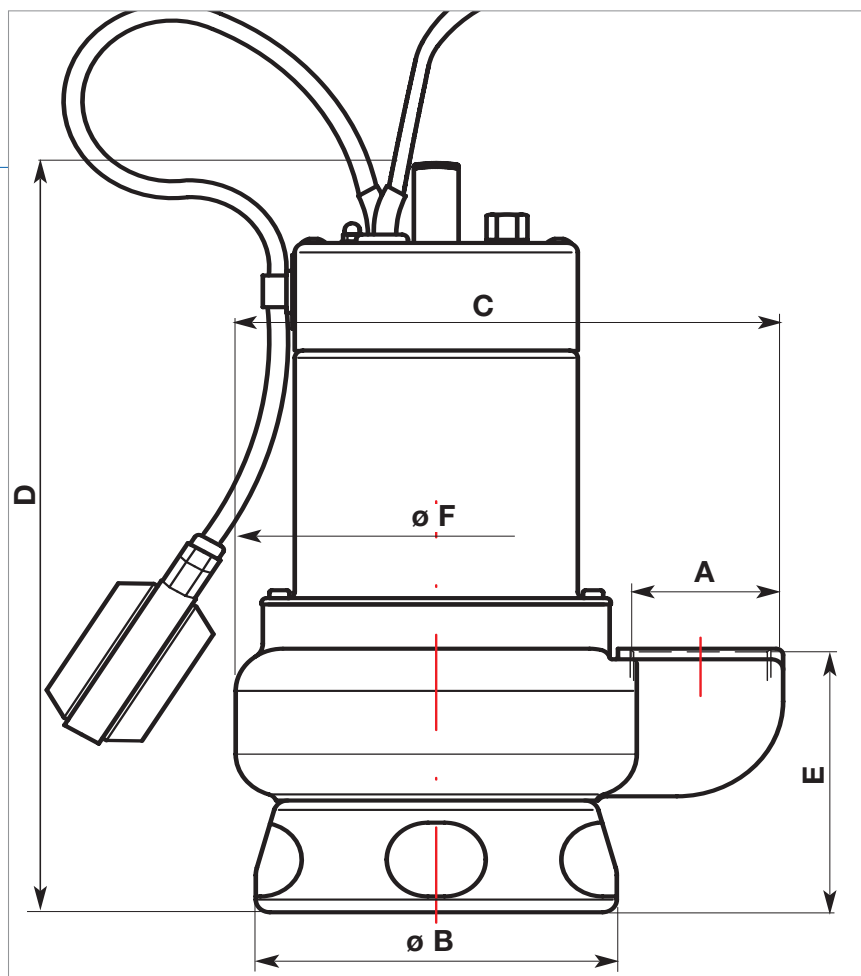

MODELLO / MODEL	DIMENSIONI POMPA in mm. / PUMP DIMENSIONS in mm.					
	A	B	C	D	E	F
TIGER 70	1" 1/2	150	232	360,5	125	170
TIGER 80	1" 1/2	150	232	372,5	125	170
TIGER 100	2"	150	232	385,5	125	170
TIGER 150	2"	150	232	395,5	125	170
TIGER 200	2"	150	232	395,5	125	170
TIGER - BC 100	2"	150	232	367	125	170
TIGER - BC 150	2"	150	232	407	125	170
TIGER - BC 200	2"	150	232	407	125	170

MODELLO / MODEL	DIMENSIONI SCATOLA / PACKING DIMENSIONS				DIMENSIONI PALLET / PALLET DIMENSIONS				
	L mm.	M mm.	N mm.	Peso / Weight Kg.	R mm.	S mm.	T mm.	nr. scatole/cartons	Peso / Weight Kg.
TIGER 70	190	230	410	11,0	800	1200	1360	60	685
TIGER 80	190	230	410	12,0	800	1200	1360	60	745
TIGER 100	190	230	410	13,0	800	1200	1360	60	805
TIGER 150	190	230	480	15,0	800	1200	1570	60	925
TIGER 200	190	230	480	15,0	800	1200	1570	60	925
TIGER BC 100	190	230	480	14,0	800	1200	1570	60	865
TIGER BC 150	190	230	480	16,0	800	1200	1570	60	985
TIGER BC 200	190	230	480	16,0	800	1200	1570	60	985

# TIGER F



**ELETTROPOMPE SOMMERGIBILI VORTEX PER ACQUE CARICHE, DOTATE DI CONTROFLANGIA**  
**SUBMERSIBLE VORTEX ELECTRIC PUMPS FOR WASTE WATER, FEATURING A COUNTER FLANGE**

**PREVALENZA** ..... : 7,0 mt. ÷ 15,5 mt.  
**PORTATA** ..... : 15,6 m<sup>3</sup>/h ÷ 75,0 m<sup>3</sup>/h  
**POTENZA NOMINALE** : 0,6 kW (0,8HP) ÷ 3,0 kW (4,0HP)  
**PASSAGGIO SOLIDI FINO A 80 mm.**

## **APPLICAZIONI**

- SVUOTAMENTO DI FOSSE DI DECANTAZIONE, POZZI DI RACCOLTA LIQUAMI
- POMPAGGIO DI ACQUE LURIDE ANCHE CON CORPI SOLIDI IN SOSPENSIONE
- MOVIMENTAZIONE DI ACQUE LURIDE AD USO DOMESTICO ED INDUSTRIALE

**PUMP HEAD** ..... : 7,0 mt ÷ 15,5 mt  
**DELIVERY** ..... : 15,6 m<sup>3</sup>/h ÷ 75,0 m<sup>3</sup>/h  
**RATED HORSEPOWER** : 0,6 kW (0,8HP) ÷ 3,0 kW (4,0HP)  
**SOLID MATTER BYPASS up to 80 mm**

## **APPLICATIONS**

- DECANTATION PIT, SEWAGE PIT AND SLURRY COLLECTION PIT PUMP OUT.
- PUMP OUT OF LAVATORY/FOUL WATER WITH POSSIBLE FLOATING SOLIDS CONTENTS.
- DOMESTIC AND INDUSTRIAL LAVATORY/BLACK WATER HANDLING SYSTEMS.

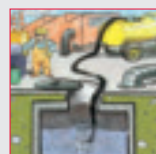
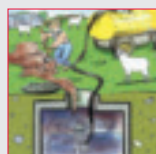
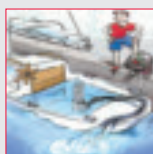
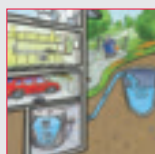

**AV ARVEN**

**CARATTERISTICHE DI COSTRUZIONE**

- ELETTOPOMPA A DOPPIA CAMERA (MOTORE, TENUTA MECCANICA).
- ELETTOPOMPA A UNICA CAMERA (SOLO PER TIGER 400F).
- MOTORE A BAGNO D'OLIO (BIODEGRADABILE E DIELETTRICO) PER RAFFREDDAMENTO E LUBRIFICAZIONE CUSCINETTI.
- ANELLO DI TENUTA LATO MOTORE.
- TENUTA MECCANICA A BAGNO D'OLIO.
- DOPPIA TENUTA MECCANICA: LATO MOTORE A BAGNO D'OLIO (SOLO PER TIGER 400F) LATO POMPA A BAGNO D'ACQUA
- IMMERSIONE MASSIMA: mt. 5 .
- GRADO DI PROTEZIONE IP 68 .
- CLASSE DI ISOLAMENTO: F
- TEMPERATURA MAX. LIQUIDO POMPATO:  
25°C con pompa PARZIALMENTE immersa.  
35°C con pompa TOTALMENTE immersa
- PASSAGGIO LIBERO: 35 mm - TIGER 80F  
50 mm - TIGER 100F - 140F - 190F  
60 mm - TIGER 150F - 200F  
80 mm - TIGER 300F - 400F
- VERSIONI: Monofase: 220-277V/50Hz o 220-277V/60Hz con protettore termico incorporato e condensatore permanentemente inserito.  
Trifase: 220-277V/50Hz o 380-480V/50Hz e 220-277V/60Hz o 380-480V/60Hz con protezione da sovraccarico a cura dell'utente.
- POTENZA MOTORE: da 0,6 kW (0,8 HP) a 1,5 kW (2 HP) versione mono fase e trifase.  
da 2,2 kW (3 HP) a 3 kW (4 HP) solo versione trifase
- VERSIONI MONOFASI AUTOMATICHE fino a 1,1 kW (1,5 HP).
- VERSIONI MONOFASI da 1,5 kW (2 HP) solo manuali senza galleggiante.
- CAVO STANDARD:  
Monofase: 10 metri H07RN-F per versione normale (aut.-man.)  
5 metri H07RN-F solo per versione automatica  
Trifase: 10 metri H07RN-F
- SPECIALI VOLTAGGI E FREQUENZE A RICHIESTA.

**OPTIONAL:**

- SISTEMI DI DISCESA DN50-DN80 PER IMPIANTI FISSI (VEDERE PAGINA 100-101)

**DESIGN ENGINEERING**

- DOUBLE CHAMBER ELECTRIC PUMP (MOTOR, MECHANICAL SEAL).
- SINGLE CHAMBER ELECTRIC PUMP (ONLY FOR TIGER 400F).
- OIL BATH MOTOR (BIODEGRADABLE AND DIELECTRIC) FOR COOLING AND BEARING LUBRICATION.
- SEALING RING - ENGINE FACE
- OIL BATH MECHANICAL SEALS.
- DOUBLE MECHANICAL SEALS: ENGINE FACE: OIL BATH (ONLY TIGER 400F) PUMP FACE: WATER BATH
- PERMISSIBLE DRAUGHT OF WATER: 5 m
- IP 68 PROTECTION CLASS.
- CLASS "F" INSULATION.
- MAX. PUMPED LIQUID TEMPERATURE:  
25°C with PARTIALLY submerged pump.  
35°C with TOTALLY submerged pump.
- BY PASS SECTION: 35 mm. - TIGER 80F  
50 mm - TIGER 100F - 140F - 190F  
60 mm - TIGER 150F - 200F  
80 mm - TIGER 300F - 400F
- VERSIONS: Single Phase: 220-277V/50Hz or 220-277V/60 Hz with built in thermal protection and permanent capacitor.  
Three Phase : 220-277V/50 Hz or 380-480V/50Hz and 220-277V/60Hz or 380-480V/60Hz with overload protection care of the User.
- MOTOR POWER:  
From 0,6 kW (0,8 HP) to 1,5 kW (2,0 HP) single phase and three phase versions.  
From 2,2 kW (3,0 HP) to 3,0 kW (4,0 HP) only three phase versions
- AUTOMATIC SINGLE PHASE VERSIONS up to 1,1 kW (1,5 HP).
- SINGLE PHASE VERSIONS from 1,5 kW (2 HP) only manual, without floater.
- STANDARD CABLE FEATURES:  
Single Phase: 10 metres H07RN-F for the standard version (automatic-manual)  
5 metres H07RN-F only for the automatic version.  
Three Phase: 10 metres H07RN-F

CUSTOMISED VOLTAGE AND FREQUENCY RATING AVAILABLE ON DEMAND.

**OPTIONAL:**

- DOWN STROKE GUIDE RAIL SYSTEMS DN50-DN80 (SEE PAGE 100-101)

**TABELLA MATERIALI / MATERIALS TABLE:**

Pos.	Componente / Component	Materiale / Materials	
A	Carcassa esterna / External housing	ACCIAIO INOX AISI 304 - DIN 1.4301 STAINLESS STEEL	
B	Girante / Impeller		
C	Albero (lato pompa) / Shaft (pump side)	ACCIAIO INOX AISI 316 DIN 1.4401 STAINLESS STEEL	
D	Tenuta meccanica Mechanical Seal	Lato motore Motor face	TIGER 80F-100F-140F-150F-190F-200F-300F ANELLO DI TENUTA NBR / NBR SEAL RING
			TIGER 400F GRAFITE - CERAMICA / GRAPHITE - CERAMIC
		Lato pompa Pump face	TIGER 80F-100F-140F-190F GRAFITE - CERAMICA / GRAPHITE - CERAMIC
			TIGER 150F-200F-300F-400F CARBURO DI SILICIO - CERAMICA SILICON CARBIDE - CERAMIC
E	Oring	NBR	
H	Carcassa motore / Motor housing	ACCIAIO INOX AISI 304 - DIN 1.4301 STAINLESS STEEL	
I	Coperchio + maniglia / Cover + handle		
R	Flangia inferiore / Lower flange	GHISA (G.20) CAST IRON	
S	Flangia superiore / Upper flange		
P	Corpo pompa / Pump body		
N	Base d'appoggio / Base holder	ACCIAIO INOX AISI 304 - DIN 1.4301 STAINLESS STEEL	
T	Controflangia d'aspirazione / Suction counter-flange		

**TIGER 80F-100F-140F  
190F-150F-200F-300F**

**TIGER 400F**

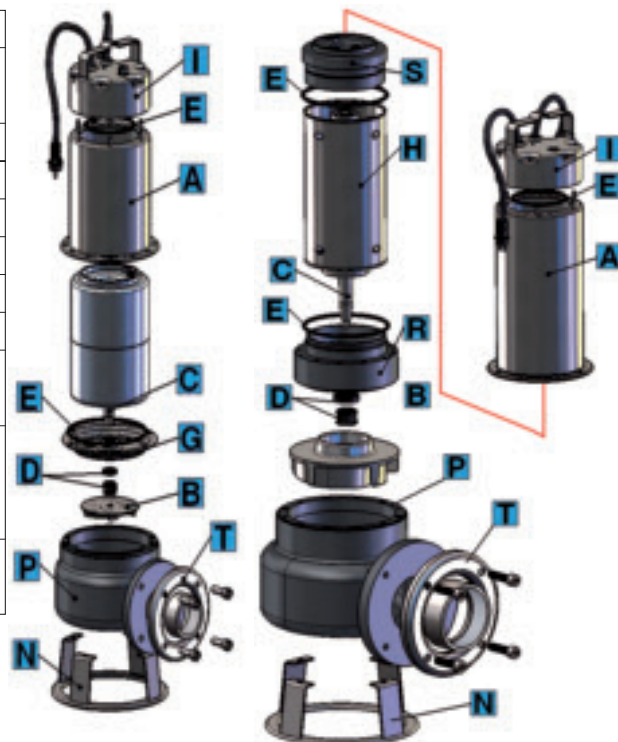

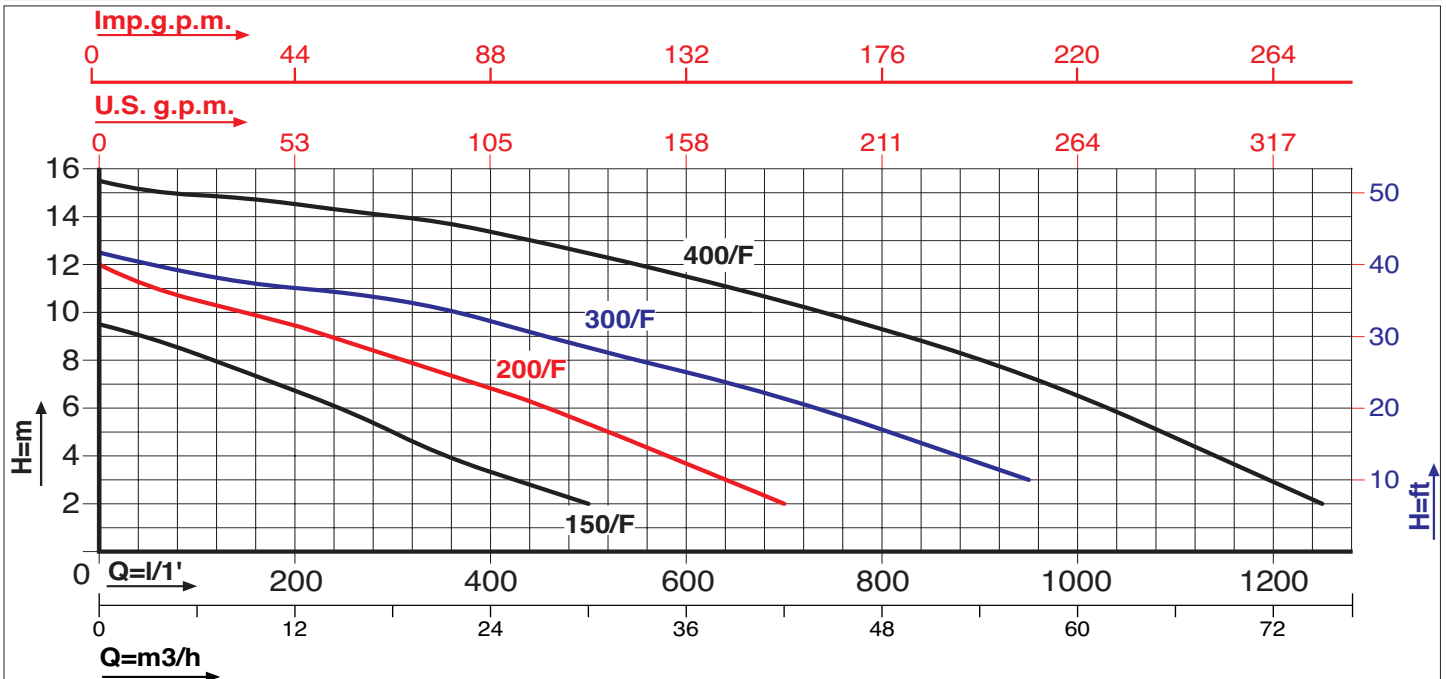
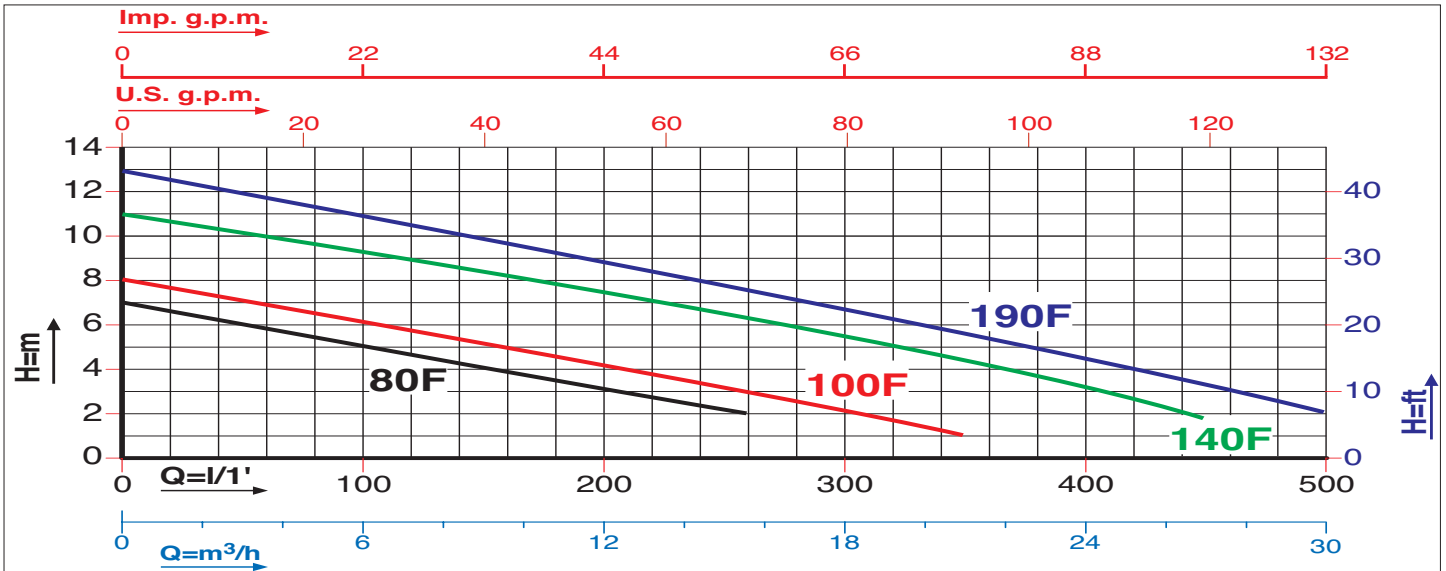

Caratteristiche di funzionamento a 2800 rpm 50Hz e 3450 rpm 60Hz - Performances at 2800 rpm 50 Hz and 3450 rpm 60 Hz  
 Le prestazioni valgono per liquidi con densità  $\rho = 1,0 \text{ kg/dm}^3$  ed una viscosità  $\nu = 1 \text{ mm}^2/\text{s}$  / The performance data holds true for liquids with a  $\rho = 1,0 \text{ kg/dm}^3$  density and a  $\nu = 1 \text{ mm}^2/\text{s}$  viscosity.

MODELLO MODEL	VOLTAGGIO VOLTAGE	DATI ELETTRICI / ELECTRICAL DATA						DATI IDRAULICI / HYDRAULIC DATA										
		P1 max kW	P2 nom. kW	HP	I max Ampere	Condensatore Capacitor		H (m)										
						µF	VC	0	9	15,6	21	27	30	42	54	75		
TIGER 80F M	1 x 220-230V	1,1	0,6	0,8	4,5	16,0	450	7,0	4,0	2,0	---	---	---	---	---	---	---	---
TIGER 80F T	3 x 380-440V	0,9	0,6	0,8	2,0	---	---	7,0	4,0	2,0	---	---	---	---	---	---	---	---
TIGER 100F M	1 x 220-230V	1,5	0,75	1,0	6,5	20,0	450	8,0	4,8	3,0	1,0	---	---	---	---	---	---	---
TIGER 100F T	3 x 380-440V	1,3	0,75	1,0	2,2	---	---	8,0	4,8	3,0	1,0	---	---	---	---	---	---	---
TIGER 140F M	1 x 220-230V	2,2	1,1	1,5	10,4	30,0	450	11,0	8,0	6,2	4,5	1,8	---	---	---	---	---	---
TIGER 140F T	3 x 380-440V	1,7	1,1	1,5	3,0	---	---	11,0	8,0	6,2	4,5	1,8	---	---	---	---	---	---
TIGER 190F M	1 x 220-230V	2,4	1,5	2,0	11,5	30,0	450	13,0	10,4	8,3	5,5	3,5	2,0	---	---	---	---	---
TIGER 190F T	3 x 380-440V	2,2	1,5	2,0	3,6	---	---	13,0	10,4	8,3	5,5	3,5	2,0	---	---	---	---	---
TIGER 150F M	1 x 220-230V	2,1	1,1	1,5	9,5	40,0	450	9,5	7,5	5,8	4,0	2,5	2,0	---	---	---	---	---
TIGER 150F T	3 x 380-440V	1,8	1,1	1,5	3,2	---	---	9,5	7,5	5,8	4,0	2,5	2,0	---	---	---	---	---
TIGER 200F M	1 x 220-230V	2,7	1,5	2,0	12,5	50,0	450	12,0	10,0	8,8	7,5	6,0	5,5	2,0	---	---	---	---
TIGER 200F T	3 x 380-440V	2,6	1,5	2,0	4,8	---	---	12,0	10,0	8,8	7,5	6,0	5,5	2,0	---	---	---	---
TIGER 300F T	3 x 380-440V	3,5	2,25	3,0	6,5	---	---	12,5	11,2	10,8	10,2	9,0	8,5	6,5	3,0	---	---	---
TIGER 400F T	3 x 380-440V	4,5	3,0	4,0	8,5	---	---	15,5	14,8	14,2	13,8	13,0	12,5	10,5	7,5	2,0	---	---

PREVALENZA TOTALE in METRI COLONNA ACQUA / TOTAL PUMP HEAD AND WATER COLUMN HEIGHT IN m.



**DIMENSIONI E PESI / SIZE AND WEIGHT DATA:**

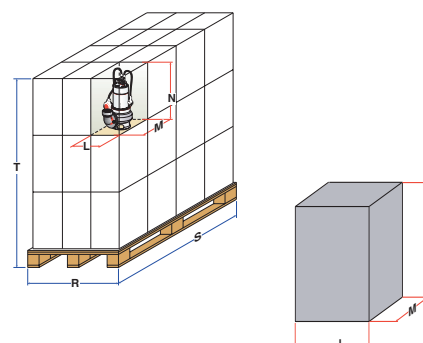
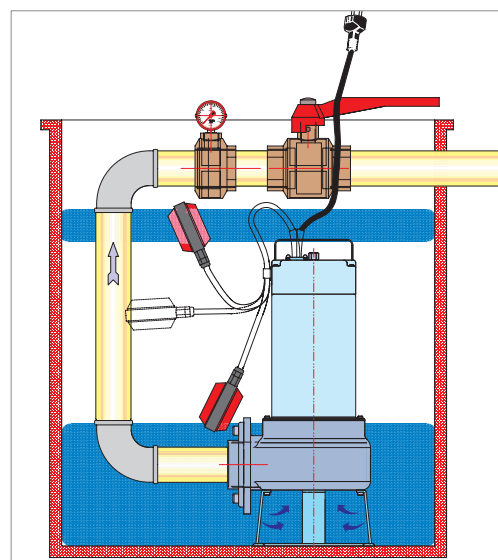
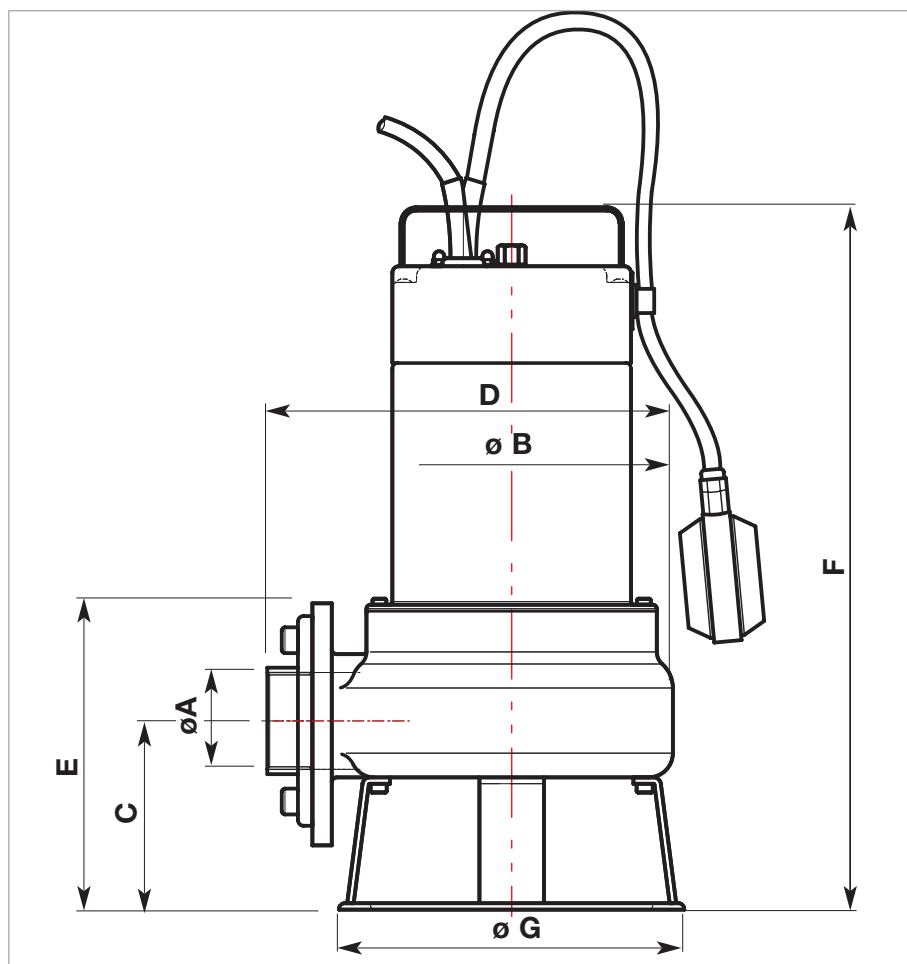

MODELLO / MODEL	DIMENSIONI POMPA in mm. / PUMP DIMENSIONS in mm.						
	A	B	C	D	E	F	G
TIGER 80F	2"	164	81,5	274	161,5	367	153
TIGER 100F	2"	164	81,5	274	161,5	367	153
TIGER 140F	2"	164	81,5	274	161,5	367	153
TIGER 190F	2"	164	81,5	274	161,5	367	153
TIGER 150F	2 1/2"	200	121	280,5	196	490	214
TIGER 200F	2 1/2"	200	121	280,5	196	490	214
TIGER 300F	3"	253	133	290	223	523,5	214
TIGER 400F	3"	253	133	290	223	523,5	214

MODELLO MODEL	DIMENSIONI SCATOLA / PACKING DIMENSIONS				DIMENSIONI PALLET / PALLET DIMENSIONS				
	L mm	M mm	N mm	Peso / Weight Kg	R mm	S mm	T mm	nr. scatole/cartons	Peso / Weight Kg
TIGER 80F	190	230	410	14,0	800	1200	1370	60	865
TIGER 100F	190	230	410	16,0	800	1200	1370	60	985
TIGER 140F	190	230	410	17,0	800	1200	1370	60	1045
TIGER 190F	190	230	410	17,5	800	1200	1370	60	1075
TIGER 150F	260	300	530	23,0	800	1200	1750	36	850
TIGER 200F	260	300	530	28,0	800	1200	1750	36	1030
TIGER 300F	260	300	550	32,0	800	1200	1810	36	1170
TIGER 400F	720	400	260	48,0	800	1200	900	9	460



# SKIPPER F



## **ELETTROPOMPE SOMMERGIBILI VORTEX PER ACQUE CARICHE, DOTATE DI CONTROFLANGIA SUBMERSIBLE VORTEX ELECTRIC PUMPS FOR WASTE WATER, FEATURING A COUNTER FLANGE**

**PREVALENZA** ..... : 7 mt. ÷ 15,5 mt.  
**PORTATA** ..... : 15,6 m<sup>3</sup>/h ÷ 75 m<sup>3</sup>/h  
**POTENZA NOMINALE** : 0,6 kW (0,8HP) ÷ 3,0 kW (4HP)  
**PASSAGGIO SOLIDI FINO A 80 mm.**

**PUMP HEAD** ..... : 7,0 mt ÷ 15,5 mt  
**DELIVERY** ..... : 15,6 m<sup>3</sup>/h ÷ 75,0 m<sup>3</sup>/h  
**RATED HORSEPOWER** : 0,6 kW (0,8HP) ÷ 3,0 kW (4,0HP)  
**SOLID MATTER BYPASS up to 80 mm**

### **APPLICAZIONI**

- SVUOTAMENTO DI FOSSE DI DECANTAZIONE, POZZI DI RACCOLTA LIQUAMI.
- POMPAGGIO DI ACQUE LURIDE ANCHE CON CORPI SOLIDI IN SOSPENSIONE.
- MOVIMENTAZIONE DI ACQUE LURIDE AD USO DOMESTICO ED INDUSTRIALE.

### **APPLICATIONS**

- DECANTATION PIT, SLURRY COLLECTION PIT PUMP OUT.
- PUMP OUT OF LAVATORY/FOUL WATER WITH POSSIBLE FLOATING SOLIDS CONTENTS.
- DOMESTIC AND INDUSTRIAL LAVATORY/BLACK WATER HANDLING SYSTEMS.

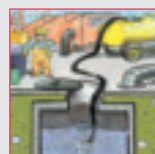
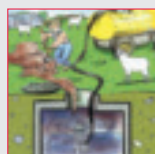
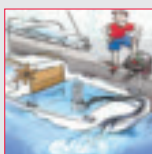
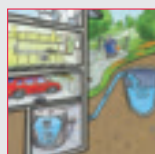

**AV ARVEN**

**CARATTERISTICHE DI COSTRUZIONE:**

- ELETTOPOMPA A DOPPIA CAMERA (MOTORE, TENUTA MECCANICA).
- ELETTOPOMPA A UNICA CAMERA (SOLO PER SKIPPER 400F ).
- MOTORE A BAGNO D'OLIO (BIODEGRADABILE E DIELETTRICO) PER RAFFREDDAMENTO E LUBRIFICAZIONE CUSCINETTI.
- ANELLO DI TENUTA LATO MOTORE.
- TENUTA MECCANICA A BAGNO D'OLIO.
- DOPPIA TENUTA MECCANICA: LATO MOTORE A BAGNO D'OLIO. (SOLO PER SKIPPER 400F) LATO POMPA A BAGNO D'ACQUA.
- IMMERSIONE MASSIMA: mt. 5 .
- GRADO DI PROTEZIONE IP 68 .
- CLASSE DI ISOLAMENTO: F
- TEMPERATURA MAX. LIQUIDO POMPATO:  
25°C con pompa PARZIALMENTE immersa.  
35°C con pompa TOTALMENTE immersa
- PASSAGGIO LIBERO: 45 mm - SKIPPER 80F - 100F - 140F -190F  
60 mm - SKIPPER 150F - 200F  
80 mm - SKIPPER 300F - 400F
- VERSIONI: Monofase: 220-277V/50Hz e 220-277V/60Hz con protettore termico incorporato e condensatore permanentemente inserito.  
Trifase: 220-277V/50Hz o 380-480V/50Hz e 220-277V/60Hz o 380-480V/60Hz con protezione da sovraccarico a cura dell'utente.
- POTENZA MOTORE: da 0,6 kW (0,8 HP) a 1,5 kW (2 HP) versione monofase e trifase.  
da 2,2 kW (3 HP) a 3 kW (4 HP) solo versione trifase
- VERSIONI MONOFASI AUTOMATICHE fino a 1,1 kW (1,5 HP).
- VERSIONI MONOFASI da 1,5 kW (2 HP) solo manuali senza galleggiante.
- CAVO STANDARD:  
Monofase: 10 metri H07RN-F per versione normale (aut.-man.)  
5 metri H07RN-F solo per versione automatica .  
Trifase: 10 metri H07RN-F

SPECIALI VOLTAGGI E FREQUENZE A RICHIESTA.

**OPTIONAL:**

- SISTEMI DI DISCESA DN50-DN80 PER IMPIANTI FISSI (VEDERE PAGINA 100-101)

**DESIGN ENGINEERING:**

- DOUBLE CHAMBER ELECTRIC PUMP (MOTOR, MECHANICAL SEAL).
- SINGLE CHAMBER ELECTRIC PUMP (ONLY FOR SKIPPER 400F ).
- OIL BATH MOTOR (BIODEGRADABLE AND DIELECTRIC) FOR COOLING AND BEARING LUBRICATION.
- SEALING RING - ENGINE FACE.
- OIL BATH MECHANICAL SEALS.
- DOUBLE MECHANICAL SEALS: ENGINE FACE: OIL BATH. (ONLY SKIPPER 400F) PUMP FACE: WATER BATH.
- PERMISSIBLE DRAUGHT OF WATER: 5 m
- IP 68 PROTECTION CLASS.
- CLASS "F" INSULATION.
- MAX. PUMPED LIQUID TEMPERATURE:  
25°C with PARTIALLY submerged pump.  
35°C with TOTALLY submerged pump.
- BY PASS SECTION: 45 mm - SKIPPER 80F - 100F - 140F - 190F  
60 mm - SKIPPER 150F - 200F  
80 mm - SKIPPER 300F - 400F
- VERSIONS: Single Phase: 220-277V/50Hz or 220-277V/60Hz with built in thermal protection and permanent capacitor.  
Three Phase: 220-277V/50Hz or 380-480V/50Hz and 220-277V/60Hz or 380-480V/60Hz with overload protection care of the User.
- MOTOR POWER: From 0,6 kW (0,8 HP) to 1,5 kW (2 HP) single phase and three phase versions.  
From 2,2 kW (3 HP) to 3 kW (4 HP) Only three phase versions
- AUTOMATIC SINGLE PHASE VERSIONS up to 1,1 kW (1,5 HP).
- SINGLE PHASE VERSIONS from 1,5 kW (2 HP) only manual, without floater
- STANDARD CABLE FEATURES:  
Single Phase: 10 metres H07RN-F for the standard version (automatic-manual)  
5 metres H07RN-F only for the automatic version.  
Three Phase: 10 metres H07RN-F

CUSTOMISED VOLTAGE AND FREQUENCY RATING AVAILABLE ON DEMAND.

**OPTIONAL:**

- DOWN STROKE GUIDE RAIL SYSTEMS DN50-DN80 FOR FIXED PLANTS (SEE PAGE 100-101)

**TABELLA MATERIALI / MATERIALS TABLE:**

Pos.	Componente / Component		Materiale / Materials
A	Carcassa esterna / External housing		ACCIAIO INOX AISI 304 - DIN 1.4301 STAINLESS STEEL
B	Girante / Impeller		
C	Albero (lato pompa) / Shaft (pump side)		ACCIAIO INOX AISI 316 DIN 1.4401 STAINLESS STEEL
D	Tenuta meccanica Mechanical Seal	Lato motore Motor face	SKIPPER 80F-100F 150F-200F-300F ANELLO DI TENUTA NBR / NBR SEAL RING
		Lato pompa Pump face	SKIPPER 400F GRAFITE - CERAMICA / GRAPHITE - CERAMIC
		SKIPPER 80F-100F GRAFITE - CERAMICA / GRAPHITE - CERAMIC	
		SKIPPER 150F-200F-300F-400F CARBURO DI SILICIO - CERAMICA SILICON CARBIDE - CERAMIC	
E	Oring		NBR
H	Carcassa motore / Motor housing		ACCIAIO INOX AISI 304 - DIN 1.4301 STAINLESS STEEL
I	Coperchio + maniglia / Cover + handle		
R	Flangia inferiore / Lower flange		GHISA (G.20) CAST IRON
S	Flangia superiore / Upper flange		
P	Corpo pompa / Pump body		ACCIAIO INOX AISI 304 - DIN 1.4301 STAINLESS STEEL
N	Base d'appoggio / Base holder		
T	Controflangia d'aspirazione / Suction counter-flange		

**SKIPPER  
80F-100F-150F-200F-300F**      **SKIPPER 400F**

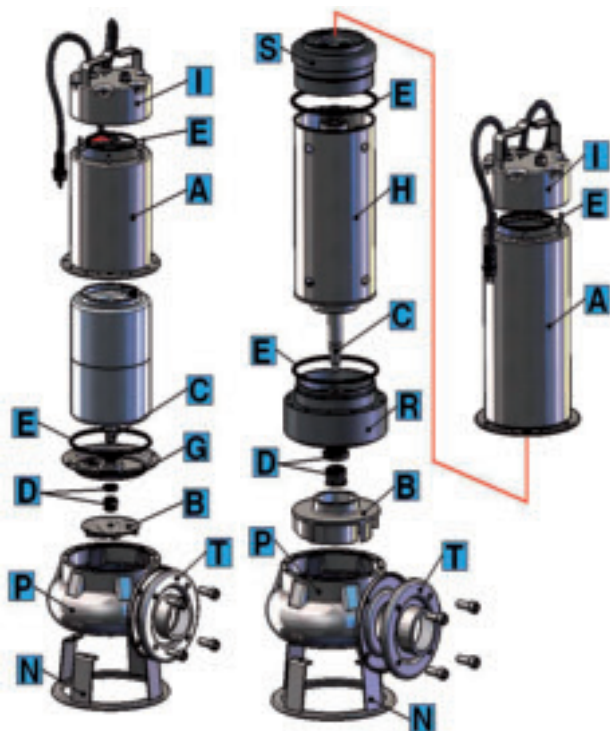

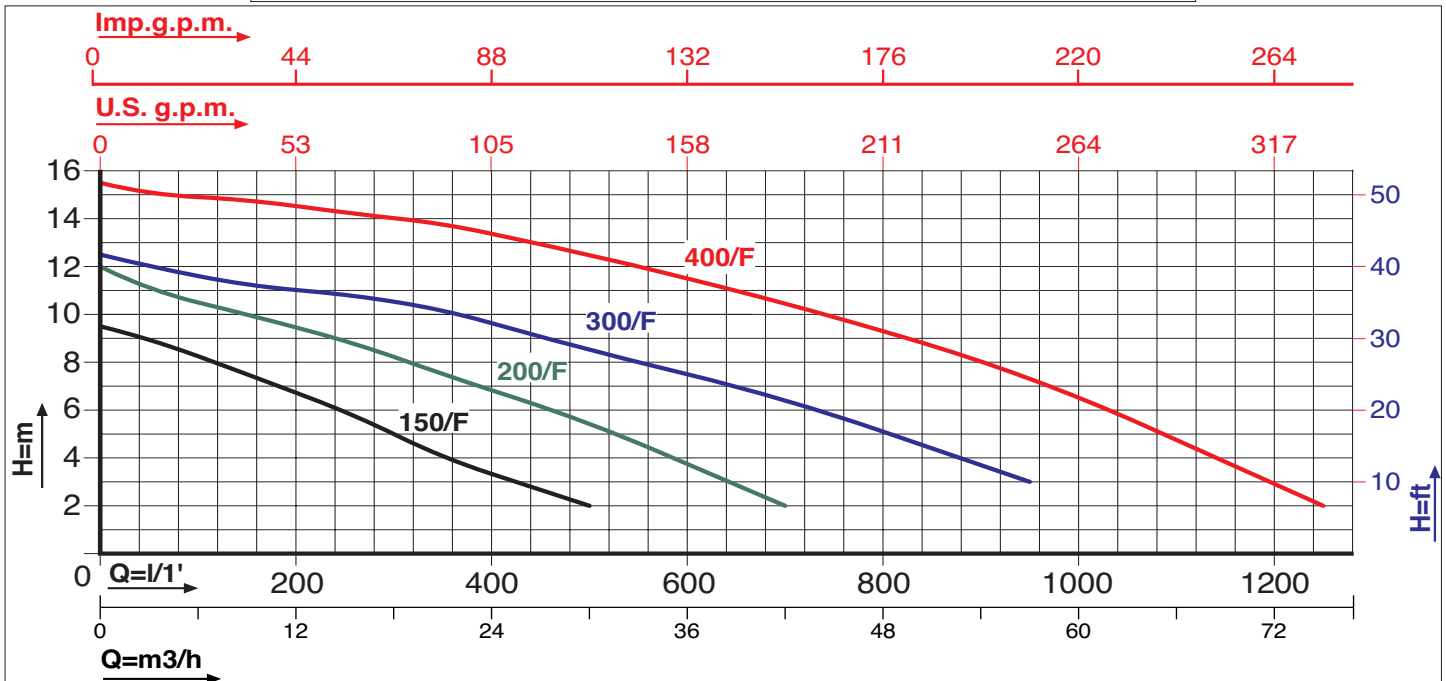
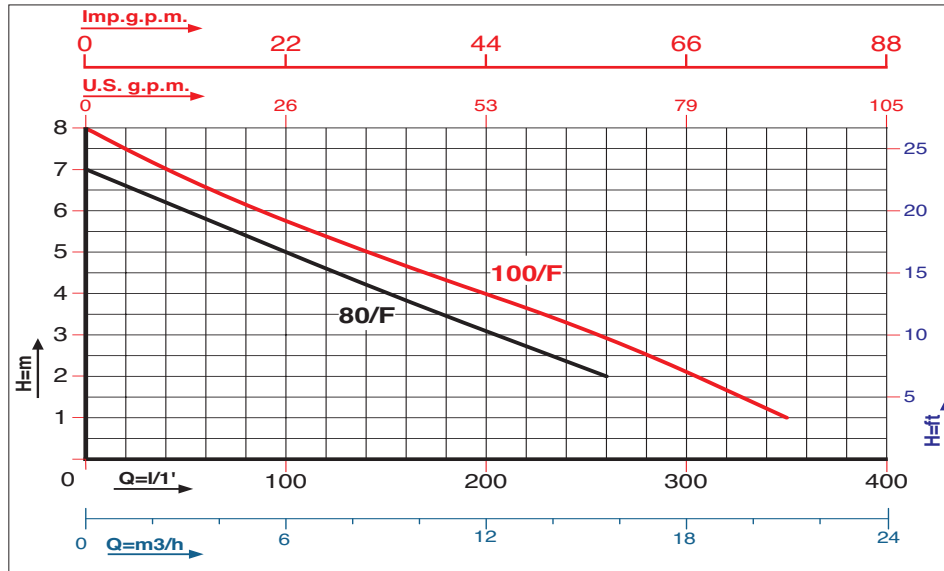

Caratteristiche di funzionamento a 2800 rpm 50Hz e 3450 rpm 60Hz - Performances at 2800 rpm 50 Hz and 3450 rpm 60 Hz  
 Le prestazioni valgono per liquidi con densità  $\rho = 1,0 \text{ kg/dm}^3$  ed una viscosità  $\nu = 1 \text{ mm}^2/\text{s}$  / The performance data holds true for liquids with a  $\rho = 1,0 \text{ kg/dm}^3$  density and a  $\nu = 1 \text{ mm}^2/\text{s}$  viscosity.

MODELLO MODEL	VOLTAGGIO VOLTAGE	DATI ELETTRICI / ELECTRICAL DATA						DATI IDRAULICI / HYDRAULIC DATA								
		P1max	P2 nom.	I max	Condensatore Capacitor		m³/h	0	3	9	15,6	21	30	42	54	75
					kW	HP										
	50 Hz						l/min.	0	50	150	260	350	500	700	900	1250
SKIPPER 80F M	1 x 220-230V	1,1	0,6	0,8	4,5	16,0	450	7,0	6,0	4,0	2,0	---	---	---	---	---
SKIPPER 80F T	3 x 380-440V	0,9	0,6	0,8	2,0	---	---	7,0	6,0	4,0	2,0	---	---	---	---	---
SKIPPER 100F M	1 x 220-230V	1,5	0,75	1,0	6,5	20,0	450	8,0	6,7	4,8	3,0	1,0	---	---	---	---
SKIPPER 100F T	3 x 380-440V	1,3	0,75	1,0	2,2	---	---	8,0	6,7	4,8	3,0	1,0	---	---	---	---
SKIPPER 150F M	1 x 220-230V	2,1	1,1	1,5	9,5	40,0	450	9,5	9,0	7,5	5,8	4,0	2,0	---	---	---
SKIPPER 150F T	3 x 380-440V	1,8	1,1	1,5	3,2	---	---	9,5	9,0	7,5	5,8	4,0	2,0	---	---	---
SKIPPER 200F M	1 x 220-230V	2,7	1,5	2,0	12,5	30,0	450	12,0	11,0	10,0	8,8	7,5	5,5	2,0	---	---
SKIPPER 200F T	3 x 380-440V	2,6	1,5	2,0	4,8	---	---	12,0	11,0	10,0	8,8	7,5	5,5	2,0	---	---
SKIPPER 300F T	3 x 380-440V	3,5	2,25	3,0	6,5	---	---	12,5	12,0	11,2	10,8	10,2	8,5	6,5	3,0	---
SKIPPER 400F T	3 x 380-440V	4,5	3,0	4,0	8,5	---	---	15,5	15,0	14,8	14,2	13,8	12,5	10,5	7,5	2,0

PREVALENZA TOTALE in METRI COLONNA ACQUA / TOTAL PUMP HEAD AND WATER COLUMN HEIGHT IN m.

**DIMENSIONI e PESI / SIZE AND WEIGHT DATA:**

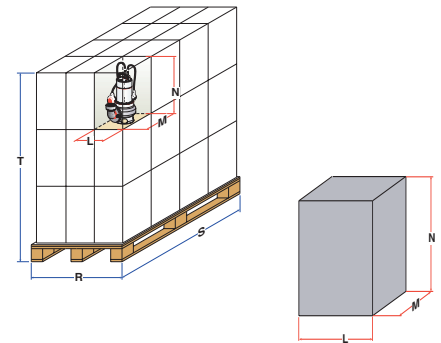
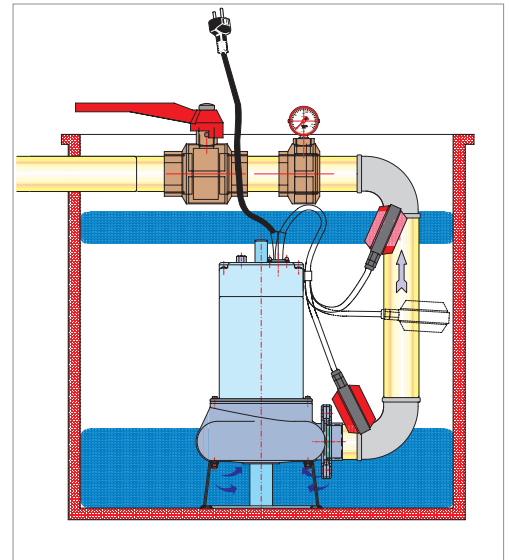
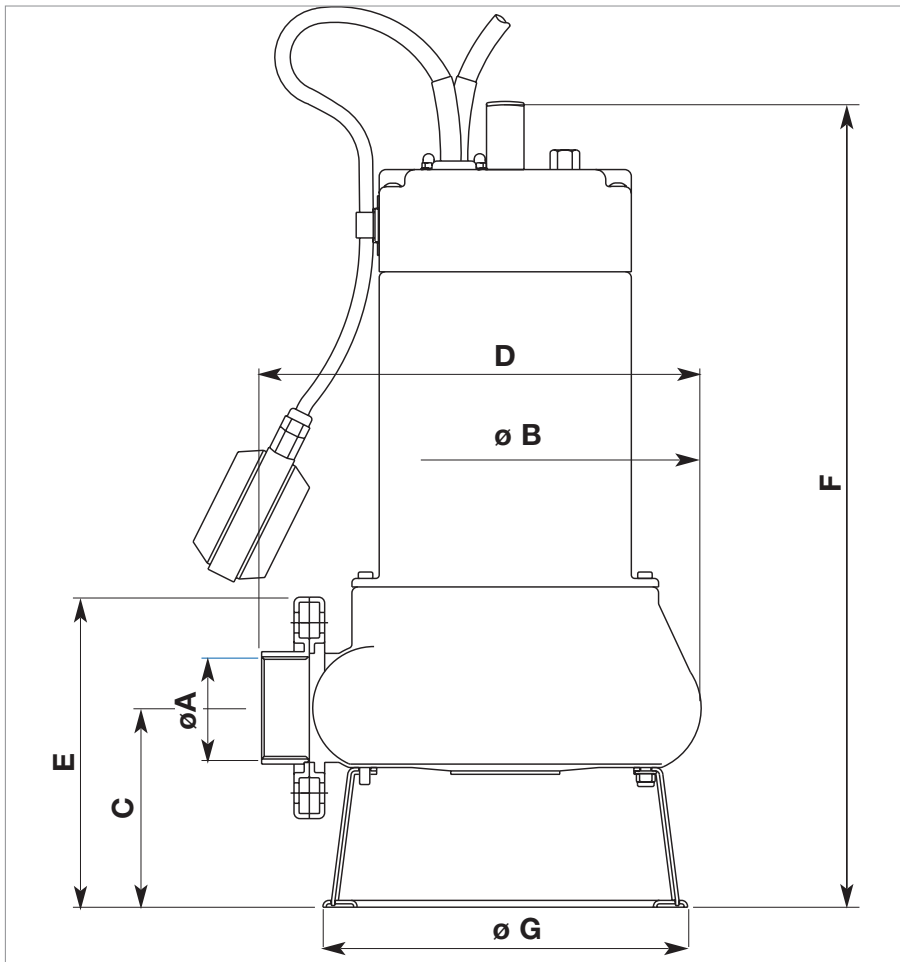

MODELLO / MODEL	DIMENSIONI POMPA in mm. / PUMP DIMENSIONS in mm.						
	A	B	C	D	E	F	G
SKIPPER 80F	2"	164	108	217	155	381	180
SKIPPER 100F	2"	164	108	217	155	381	180
SKIPPER 150F	2 1/2"	253	116,5	260	192	473	214
SKIPPER 200F	2 1/2"	253	116,5	260	192	473	214
SKIPPER 300F	3"	253	127	278	217	515	214
SKIPPER 400F	3"	253	127	278	217	641	214

MODELLO MODEL	DIMENSIONI SCATOLA / PACKING DIMENSIONS				DIMENSIONI PALLET / PALLET DIMENSIONS				
	L mm	M mm	N mm	Peso / Weight Kg	R mm	S mm	T mm	nr. scatole/cartons	Peso / Weight Kg
SKIPPER 80F	190	230	410	10,5	800	1200	1370	60	655
SKIPPER 100F	190	230	410	11,5	800	1200	1370	60	715
SKIPPER 150F	260	300	530	19,0	800	1200	1750	36	709
SKIPPER 200F	260	300	530	22,5	800	1200	1750	36	835
SKIPPER 300F	260	300	550	23,0	800	1200	1810	36	850
SKIPPER 400F	720	400	260	39,0	800	1200	900	9	380



# SKIPPER



## **ELETTROPOMPE SOMMERSIBILI VORTEX PER ACQUE CARICHE SUBMERSIBLE VORTEX ELECTRIC PUMPS FOR WASTEWATER**

**PREVALENZA** ..... : 7,5 mt. ÷ 13,0 mt.  
**PORTATA** ..... : 15,6 m<sup>3</sup>/h ÷ 30,0 m<sup>3</sup>/h  
**POTENZA NOMINALE** : 0,6 kW (0,8HP) ÷ 1,5 kW (2,0HP)  
**PASSAGGIO SOLIDI FINO A 50 mm.**

### **APPLICAZIONI**

- SVUOTAMENTO DI FOSSE DI DECANTAZIONE, POZZI NERI, POZZI DI RACCOLTA LIQUAMI.
- POMPAGGIO DI ACQUE LURIDE ANCHE CON CORPI SOLIDI IN SOSPENSIONE.
- MOVIMENTAZIONE DI ACQUE LURIDE AD USO DOMESTICO ED INDUSTRIALE.

**PUMP HEAD** ..... : 7,5 mt ÷ 13,0 mt  
**DELIVERY** ..... : 15,6 m<sup>3</sup>/h ÷ 30,0 m<sup>3</sup>/h  
**RATED HORSEPOWER** : 0,6 kW (0,8HP) ÷ 1,5 kW (2,0HP)  
**SOLID MATTER BYPASS up to 50 mm**

### **APPLICATIONS**

- DECANTATION PIT, SEWAGE PIT AND SLURRY COLLECTION PIT PUMP OUT.
- PUMP OUT OF LAVATORY/FOUL WATER WITH POSSIBLE FLOATING SOLIDS CONTENTS.
- DOMESTIC AND INDUSTRIAL LAVATORY/BLACK WATER HANDLING SYSTEMS.

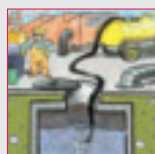
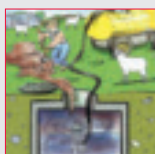
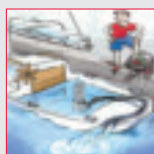
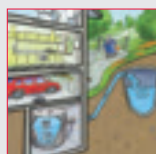

**AV ARVEN**

**CARATTERISTICHE DI COSTRUZIONE:**

- ELETTOPOMPA A DOPPIA CAMERA (MOTORE, TENUTA MECCANICA).
  - MOTORE A BAGNO D'OLIO (BIODEGRADABILE E DIELETRICO) PER RAFFREDDAMENTO E LUBRIFICAZIONE CUSCINETTI.
  - ANELLO DI TENUTA LATO MOTORE.
  - TENUTA MECCANICA A BAGNO D'OLIO.
  - IMMERSIONE MASSIMA: mt. 5.
  - GRADO DI PROTEZIONE IP 68.
  - CLASSE DI ISOLAMENTO: F.
  - TEMPERATURA MAX. LIQUIDO POMPATO:  
25°C con pompa PARZIALMENTE immersa.  
35°C con pompa TOTALMENTE immersa.
  - PASSAGGIO LIBERO: 35 mm - SKIPPER 80.  
50 mm - SKIPPER 100 - 150 - 200.
  - VERSIONI: Monofase: 220-277V/50Hz e 220-277V/60Hz con protettore termico incorporato e condensatore permanentemente inserito.  
Trifase: 220-277V/50Hz o 380-480V/50Hz e 220-277V/60Hz o 380-480V/60Hz con protezione da sovraccarico a cura dell'utente.
  - VERSIONI MONOFASI AUTOMATICHE CON GALLEGGIANTE O MANUALI SENZA GALLEGGIANTE.
  - CAVO STANDARD:  
Monofase: 10 metri H07RN-F per versione normale (aut.-man.).  
Trifase: 10 metri H07RN-F.
- SPECIALI VOLTAGGI E FREQUENZE A RICHIESTA.

**DESIGN ENGINEERING:**

- DOUBLE CHAMBER ELECTRIC PUMP (MOTOR, MECHANICAL SEAL).
  - OIL BATH MOTOR (BIODEGRADABLE AND DIELECTRIC) FOR COOLING AND BEARING LUBRICATION.
  - SEALING RING - ENGINE FACE.
  - OIL BATH MECHANICAL SEALS.
  - PERMISSIBLE DRAUGHT OF WATER: 5 m.
  - IP 68 PROTECTION CLASS.
  - CLASS "F" INSULATION.
  - MAX. PUMPED LIQUID TEMPERATURE:  
25°C with PARTIALLY submerged pump.  
35°C with TOTALLY submerged pump.
  - BY PASS SECTION: 35 mm - SKIPPER 80.  
50 mm - SKIPPER 100 - 150 - 200.
  - VERSIONS: Single Phase: 220-277V/50Hz or 220-277V/60 Hz with built in thermal protection and permanent capacitor.  
Three Phase :220-277V/50Hz or 380-480V/50Hz and 220-277V/60Hz or 380-480V/60Hz with overload protection care of the User
  - AUTOMATIC SINGLE PHASE VERSIONS WITH FLOATER OR MANUAL SINGLE PHASE VERSIONS, WITHOUT FLOATER.
  - STANDARD CABLE FEATURES:  
Single Phase: 10 metres H07RN-F for the standard version (automatic-manual).  
Three Phase: 10 metres H07RN-F.
- CUSTOMISED VOLTAGE AND FREQUENCY RATING AVAILABLE ON DEMAND.

**TABELLA MATERIALI / MATERIALS TABLE:**

Pos.	Componente / Component	Materiale / Materials	
A	Carcassa esterna / External housing	ACCIAIO INOX AISI 304 - DIN 1.4301 STAINLESS STEEL	
B	Girante / Impeller		
C	Albero (lato pompa) / Shaft (pump side)	ACCIAIO INOX AISI 316 - DIN 1.4401 STAINLESS STEEL	
D	Tenuta meccanica Mechanical seal	Lato pompa / Pump side	GRAFITE-CERAMICA GRAPHITE-CERAMIC
		Lato motore / Motor side	ANELLO DI TENUTA NBR NBR SEAL RING
E	O-ring	NBR	
G	Porta motore / Motor holder	ACCIAIO INOX AISI 304 - DIN 1.4301 STAINLESS STEEL	
I	Coperchio + maniglia / Cover + handle		
N	Base d'appoggio / Base holder		
P	Corpo pompa / Pump body		

**SKIPPER 80 - 100 - 150 - 200**

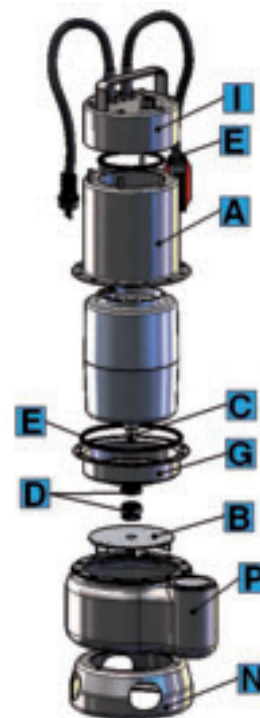



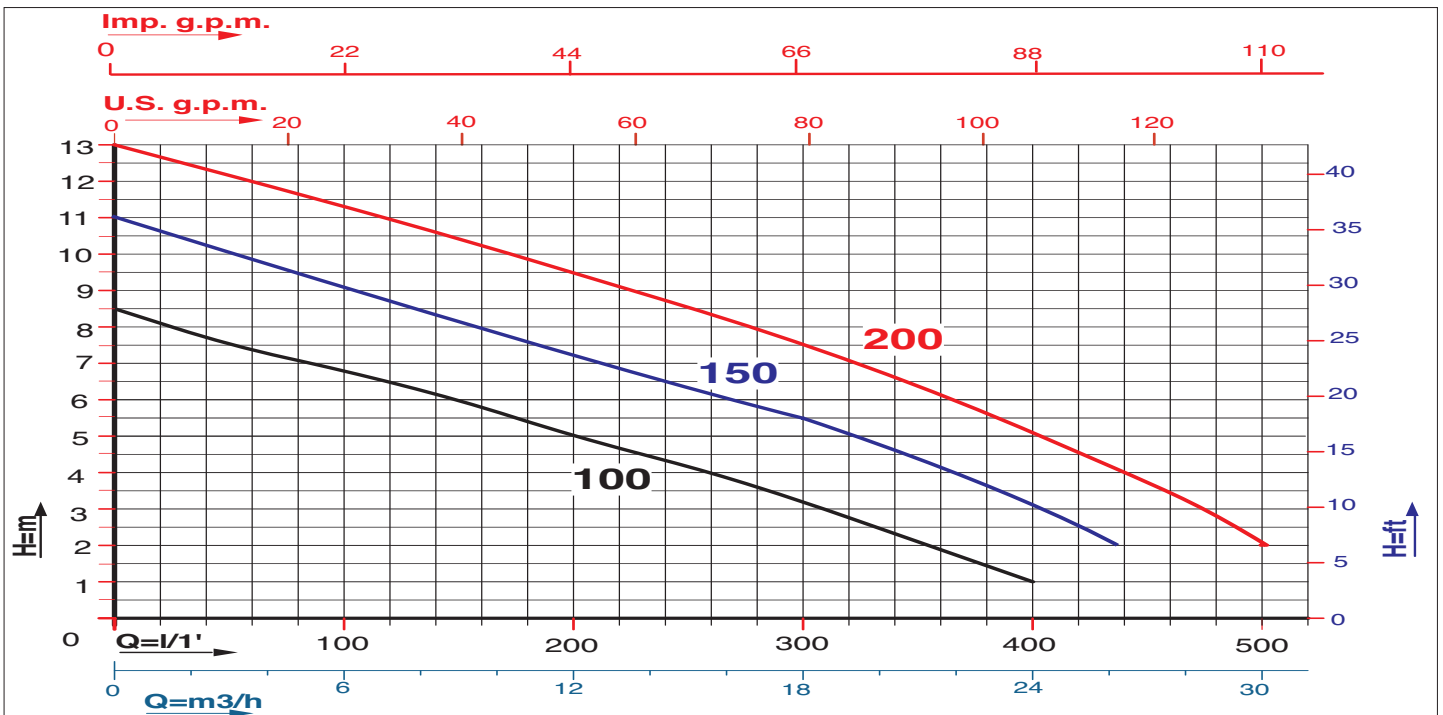
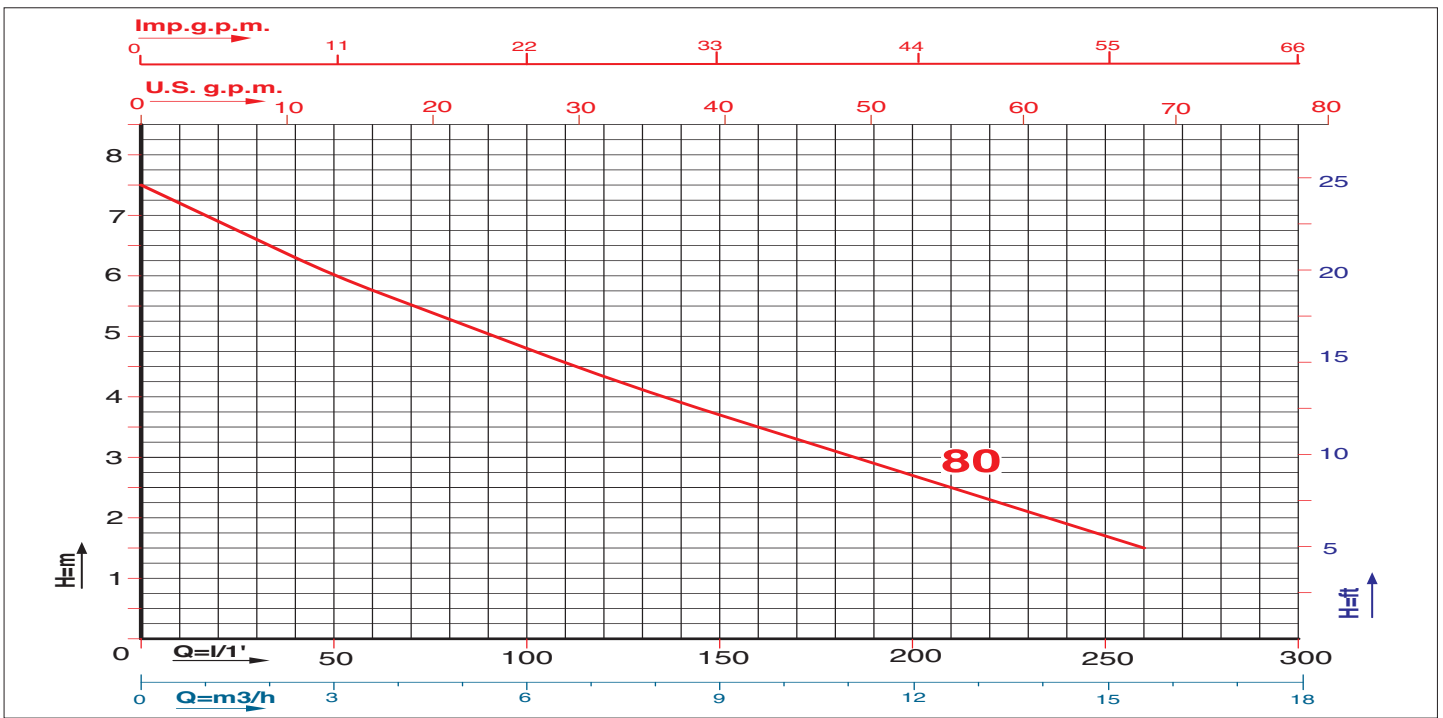

Caratteristiche di funzionamento a 2800 rpm 50Hz e 3450 rpm 60Hz - Performances at 2800 rpm 50 Hz and 3450 rpm 60 Hz  
 Le prestazioni valgono per liquidi con densità  $\rho = 1,0 \text{ kg/dm}^3$  ed una viscosità  $\nu = 1 \text{ mm}^2/\text{s}$  / The performance data holds true for liquids with a  $\rho = 1,0 \text{ kg/dm}^3$  density and a  $\nu = 1 \text{ mm}^2/\text{s}$  viscosity.

MODELLO MODEL	VOLTAGGIO VOLTAGE	DATI ELETTRICI / ELECTRICAL DATA						DATI IDRAULICI / HYDRAULIC DATA																			
		P1 <sub>max</sub>	P2 nom.		I <sub>max</sub>	Condensatore Capacitor		m³/h		H (m)																	
50 Hz		kW	kW	HP	Ampere	µF	VC	0	3	6	9	12	15,6	18	24	27	30	0	50	100	150	200	260	300	400	450	500
SKIPPER 80 M	1 x 220-230V	1,1	0,6	0,8	5,0	16,0	450	7,5	6,0	4,8	3,7	2,7	1,5	---	---	---	---	7,5	6,0	4,8	3,7	2,7	1,5	---	---	---	---
SKIPPER 80 T	3 x 380-440V	0,9	0,6	0,8	2,0	---	---	8,5	7,5	6,8	6,0	5,0	4,0	3,2	1,0	---	---	8,5	7,5	6,8	6,0	5,0	4,0	3,2	1,0	---	---
SKIPPER 100 M	1 x 220-230V	1,5	0,75	1,0	6,5	20,0	450	11,0	9,8	9,0	8,0	7,3	6,2	5,6	3,2	1,8	---	11,0	9,8	9,0	8,0	7,3	6,2	5,6	3,2	1,8	---
SKIPPER 100 T	3 x 380-440V	1,3	0,75	1,0	2,4	---	---	13,0	12,2	11,2	10,4	9,5	8,3	7,5	5,2	3,0	2,0	13,0	12,2	11,2	10,4	9,5	8,3	7,5	5,2	3,0	2,0
SKIPPER 150 M	1 x 220-230V	2,2	1,1	1,5	10,4	30,0	450	13,0	12,2	11,2	10,4	9,5	8,3	7,5	5,2	3,0	2,0	13,0	12,2	11,2	10,4	9,5	8,3	7,5	5,2	3,0	2,0
SKIPPER 150 T	3 x 380-440V	1,7	1,1	1,5	3,0	---	---	---	---	---	---	---	---	---	---	---	---	---	---	---	---	---	---	---	---	---	---
SKIPPER 200 M	1 x 220-230V	2,4	1,5	2,0	11,5	30,0	450	---	---	---	---	---	---	---	---	---	---	---	---	---	---	---	---	---	---	---	---
SKIPPER 200 T	3 x 380-440V	2,2	1,5	2,0	3,6	---	---	---	---	---	---	---	---	---	---	---	---	---	---	---	---	---	---	---	---	---	---

PREVALENZA TOTALE in METRI COLONNA ACQUA / TOTAL PUMP HEAD AND WATER COLUMN HEIGHT IN m.

**DIMENSIONI E PESI / SIZE AND WEIGHT DATA:**

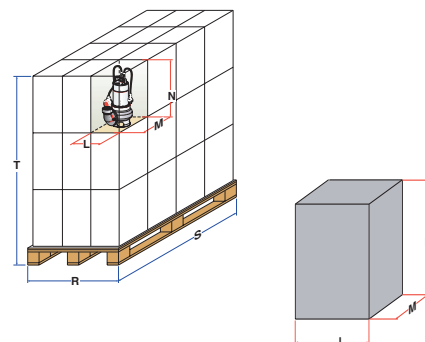
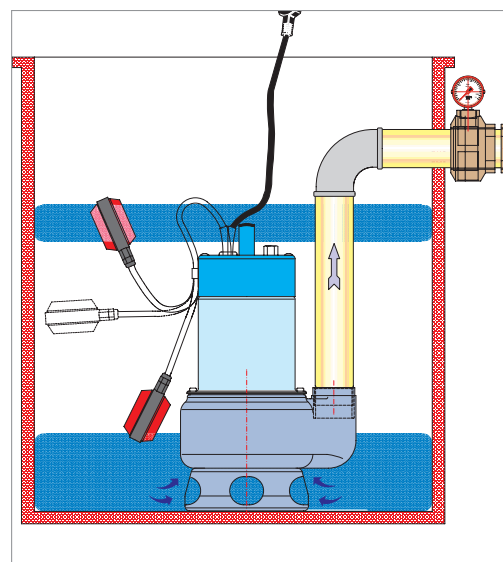
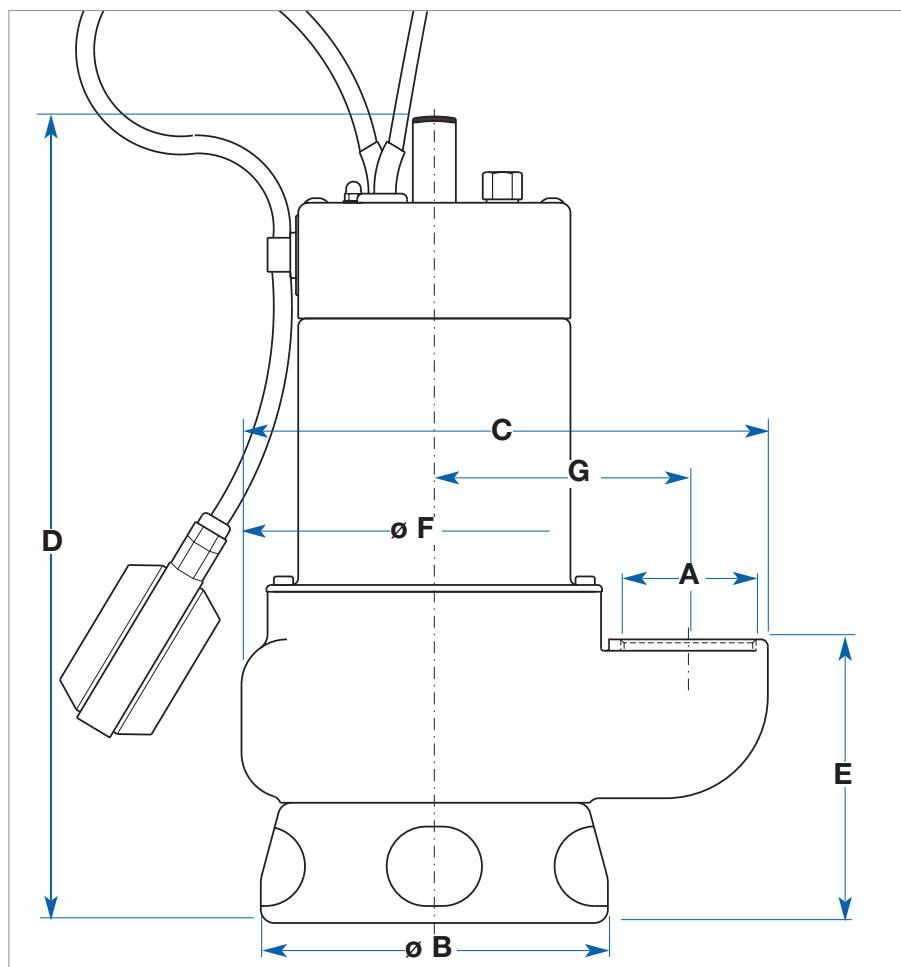

MODELLO / MODEL	DIMENSIONI POMPA in mm. / PUMP DIMENSIONS in mm.						
	A	B	C	D	E	F	G
SKIPPER 80	1" 1/2	164	217	355	153	164	108
SKIPPER 100	1" 1/2	164	217	355	153	164	108
SKIPPER 150	2"	164	221	395	178	164	108
SKIPPER 200	2"	164	221	395	178	164	108

MODELLO MODEL	DIMENSIONI SCATOLA / PACKING DIMENSIONS				DIMENSIONI PALLET / PALLET DIMENSIONS				
	L mm	M mm	N mm	Peso / Weight Kg	R mm	S mm	T mm	nr. scatole/cartons	Peso / Weight Kg
SKIPPER 80	190	230	410	10,5	800	1200	1360	60	650
SKIPPER 100	190	230	410	11,5	800	1200	1360	60	715
SKIPPER 150	190	230	410	13,5	800	1200	1360	60	835
SKIPPER 200	190	230	410	13,5	800	1200	1360	60	835

# ARVEX/S aisi 316



## **ELETTROPOMPE SOMMERSIBILI VORTEX E BICANALI PER ACQUE CARICHE E LIQUIDI AGGRESSIVI SUBMERSIBLE VORTEX AND BICANAL ELECTRIC PUMPS FOR WASTEWATER AND AGGRESSIVE LIQUIDS**

**PREVALENZA** ..... : 10,5 m ÷ 16,0 m  
**PORTATA** ..... : 13,8 m<sup>3</sup>/h ÷ 42 m<sup>3</sup>/h  
**POTENZA NOMINALE** : 0,6 kW (0,8HP) ÷ 2,2 kW (2HP)  
**PASSAGGIO SOLIDI FINO A 50 mm.**

**PUMP HEAD** ..... : 10,5 mt ÷ 16,0 mt  
**DELIVERY** ..... : 13,8 m<sup>3</sup>/h ÷ 42,0 m<sup>3</sup>/h  
**RATED HORSEPOWER** : 0,6 kW (0,8HP) ÷ 2,2 kW (2,0HP)  
**SOLID MATTER BYPASS up to 50 mm.**

### **APPLICAZIONI**

- SVUOTAMENTO DI FOSSE DI DECANTAZIONE, POZZI NERI, POZZI DI RACCOLTA LIQUAMI.
- POMPAGGIO DI ACQUE LURIDE ANCHE CON CORPI SOLIDI IN SOSPENSIONE.
- MOVIMENTAZIONE DI ACQUE LURIDE AD USO DOMESTICO ED INDUSTRIALE.
- POMPAGGIO DI LIQUIDI AGGRESSIVI

### **APPLICATIONS**

- DECANTATION PIT, SEWAGE PIT AND SLURRY COLLECTION PIT PUMP OUT.
- PUMP OUT OF LAVATORY/FOUL WATER WITH POSSIBLE FLOATING SOLIDS CONTENTS.
- DOMESTIC AND INDUSTRIAL LAVATORY/BLACK WATER HANDLING SYSTEMS.
- PUMPING OF AGGRESSIVE MEDIA.

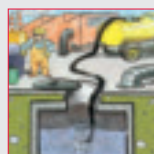
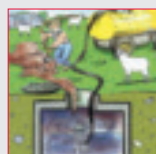
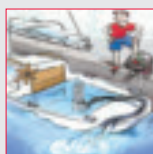
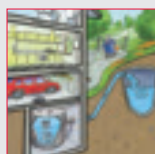

**ARVEN**

**CARATTERISTICHE DI COSTRUZIONE:**

- ELETTOPOMPA A DOPPIA CAMERA (MOTORE, TENUTA MECCANICA).
  - MOTORE A BAGNO D'OLIO (BIODEGRADABILE E DIELETTRICO) PER RAFFREDDAMENTO E LUBRIFICAZIONE CUSCINETTI.
  - ANELLO DI TENUTA LATO MOTORE.
  - TENUTA MECCANICA A BAGNO D'OLIO.
  - IMMERSIONE MASSIMA: mt. 5 .
  - GRADO DI PROTEZIONE IP 68 .
  - CLASSE DI ISOLAMENTO: F
  - TEMPERATURA MAX. LIQUIDO POMPATO:  
25°C con pompa PARZIALMENTE immersa.  
35°C con pompa TOTALMENTE immersa.
  - PASSAGGIO LIBERO: 30 mm - ARVEX 80 S.  
50 mm - ARVEX 100 S - 150 S.
  - VERSIONI:  
Monofase: 220-277V/50Hz o 220-277V/60Hz con protettore termico incorporato e condensatore permanentemente inserito.  
Trifase: 220-277V/50Hz o 380-480V/50Hz e 220-277V/60Hz o 380-480V/60Hz con protezione da sovraccarico a cura dell'utente.
  - VERSIONI MONOFASI AUTOMATICHE CON GALLEGGIANTE O MANUALI SENZA GALLEGGIANTE.
  - CAVO STANDARD:  
Monofase: 10 metri H05VV-F per versione normale (aut.-man.).  
Trifase: 10 metri H05VV-F.
- SPECIALI VOLTAGGI E FREQUENZE A RICHIESTA.

**DESIGN ENGINEERING**

- DOUBLE CHAMBER ELECTRIC PUMP (MOTOR, MECHANICAL SEAL).
  - OIL BATH MOTOR (BIODEGRADABLE AND DIELECTRIC) FOR COOLING AND BEARING LUBRICATION.
  - SEALING RING - ENGINE FACE
  - OIL BATH MECHANICAL SEALS.
  - PERMISSIBLE DRAUGHT OF WATER: 5 m.
  - IP 68 PROTECTION CLASS.
  - CLASS "F" INSULATION.
  - MAX. PUMPED LIQUID TEMPERATURE:  
25°C with PARTIALLY submerged pump.  
35°C with TOTALLY submerged pump.
  - BY PASS SECTION: 30 mm - ARVEX 80 S.  
50 mm - ARVEX 100 S - 150 S.
  - VERSIONS:  
Single Phase: 220-277V/50Hz or 220-277V/60 Hz with built in thermal protection and permanent capacitor.  
Three Phase: 220-277V/50Hz or 380-480V/50Hz and 220-277V/60Hz or 380-480V/60Hz with overload protection care of the User.
  - AUTOMATIC SINGLE PHASE VERSIONS WITH FLOATER OR MANUAL WITHOUT FLOATER.
  - STANDARD CABLE FEATURES:  
Single Phase: 10 metres H05VV-F for the standard version (automatic-manual).  
Three Phase: 10 metres H05VV-F.
- CUSTOMISED VOLTAGE AND FREQUENCY RATING AVAILABLE ON DEMAND.

**TABELLA MATERIALI / MATERIALS TABLE:**

Pos.	Componente / Component		Materiale / Materials
A	Carcassa esterna / External housing		ACCIAIO INOX AISI 316 DIN 1.4401 STAINLESS STEEL
B	Girante / Impeller		
C	Albero (lato pompa) / Shaft (pump side)		
D	Tenuta meccanica Mechanical seal	Lato pompa / Pump face	CARBURO DI SILICIO-VITON SILICON CARBIDE-VITON
		Lato motore / Motor face	ANELLO DI TENUTA NBR NBR SEAL RING
E	O-ring		VITON
G	Porta motore / Motor holder		ACCIAIO INOX AISI 316 DIN 1.4401 STAINLESS STEEL
I	Coperchio + maniglia / Cover + handle		
N	Base d'appoggio / Base holder		
P	Corpo pompa / Pump body		

**ARVEX 80/S - 100/S - 150/S**

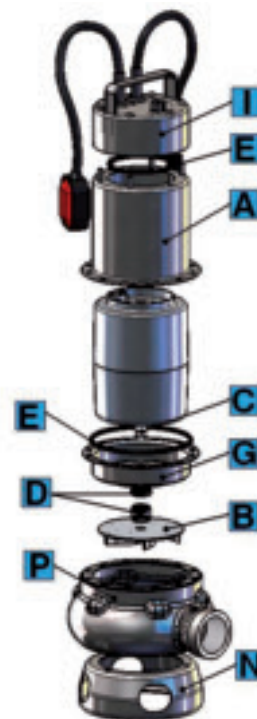

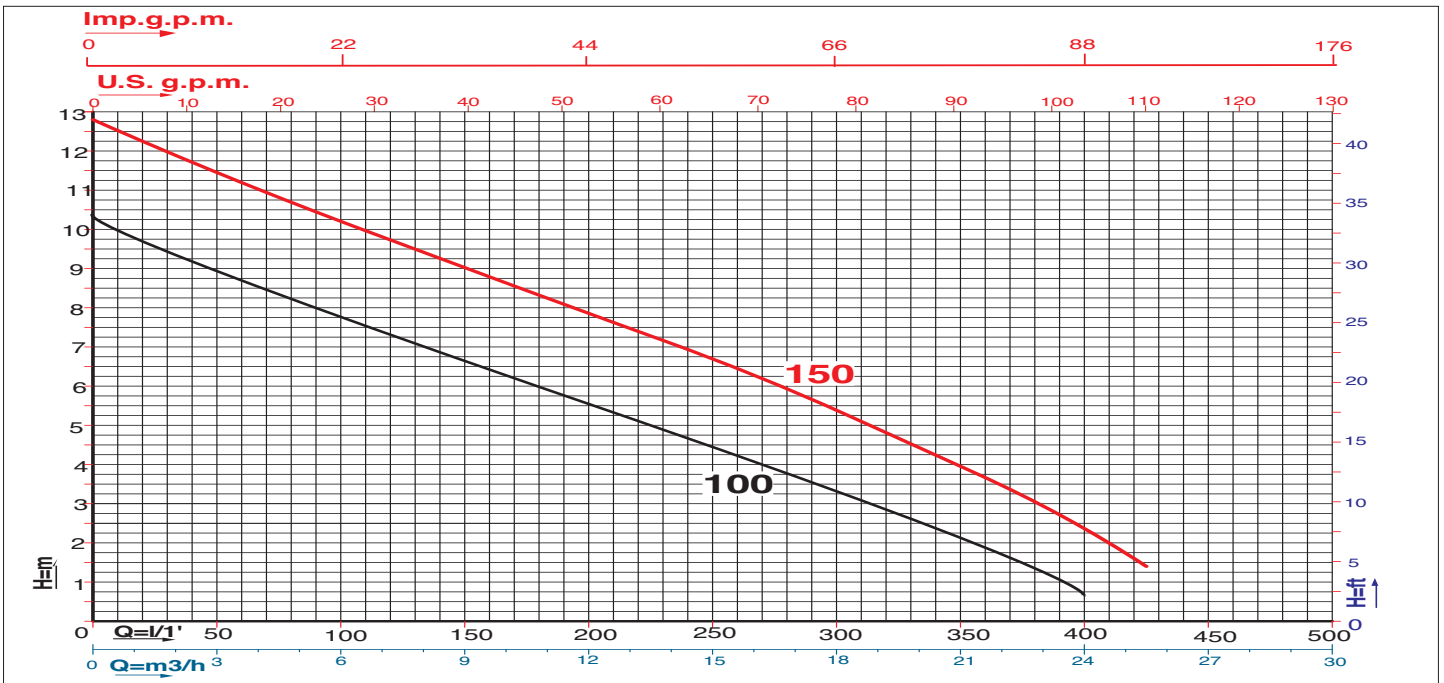
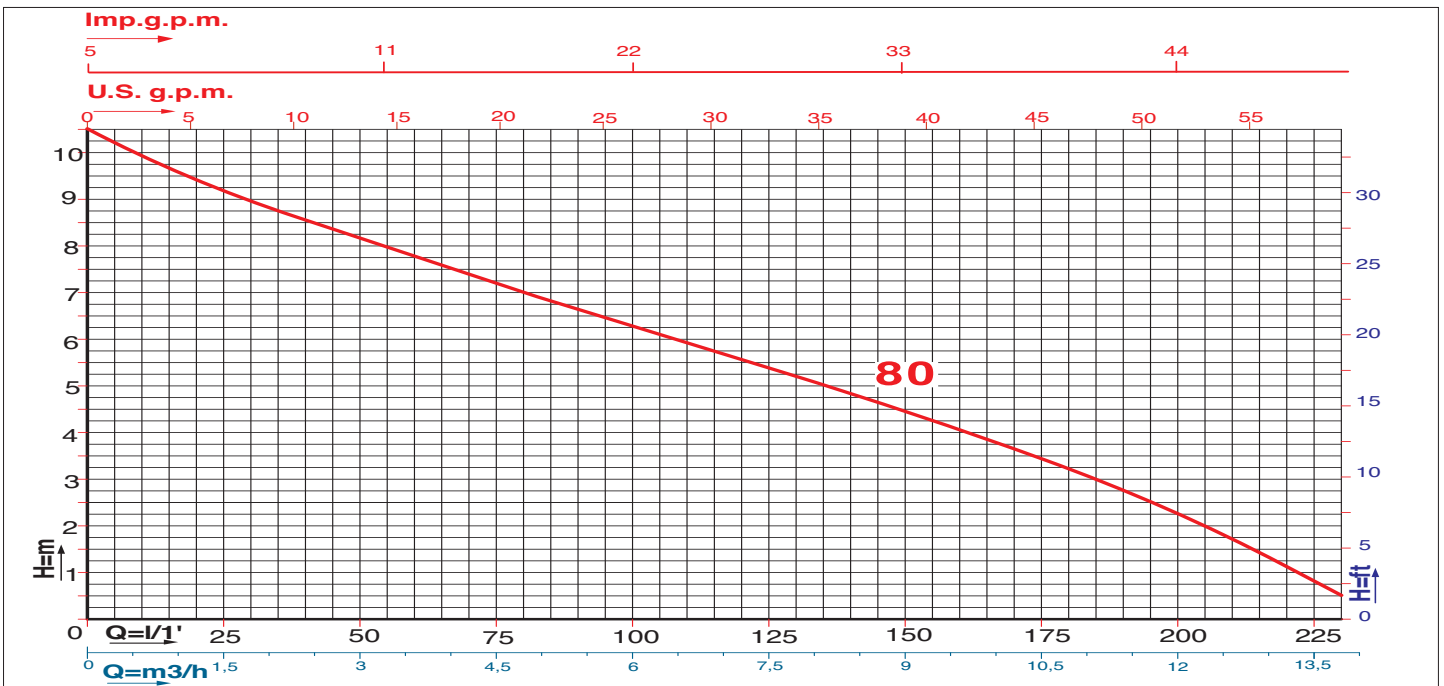

Caratteristiche di funzionamento a 2800 rpm 50Hz e 3450 rpm 60Hz - Performances at 2800 rpm 50 Hz and 3450 rpm 60 Hz  
 Le prestazioni valgono per liquidi con densità  $\rho = 1,0 \text{ kg/dm}^3$  ed una viscosità  $\nu = 1 \text{ mm}^2/\text{s}$  / The performance data holds true for liquids with a  $\rho = 1,0 \text{ kg/dm}^3$  density and a  $\nu = 1 \text{ mm}^2/\text{s}$  viscosity.

MODELLO MODEL	VOLTAGGIO VOLTAGE 50Hz	DATI ELETTRICI / ELECTRICAL DATA						DATI IDRAULICI / HYDRAULIC DATA									
		P1 max kW	P2 nom. kW	I max HP	I max Ampere	Condensatore Capacitor		m³/h	0	3	6	9	12	13,8	18	24	25,5
						µF	VC										
ARVEX/S 80 M	1 x 220-230V	1,1	0,6	0,8	5,0	16	450	H (m)	10,5	8,2	6,3	4,5	2,3	0,6			
ARVEX/S 80 T	3 x 220V or 380V	0,9	0,6	0,8	2,1	---	---		10,5	8,2	6,3	4,5	2,3	0,6			
ARVEX/S 100 M	1 x 220-230V	1,5	0,75	1,0	6,5	20	450		10,5	8,6	7,6	6,6	5,4	4,4	3,2	0,6	
ARVEX/S 100 T	3 x 220V or 380V	1,3	0,75	1,0	2,6	---	---		10,5	8,6	7,6	6,6	5,4	4,4	3,2	0,6	
ARVEX/S 150 M	1 x 220-230V	2,2	1,1	1,5	9,4	30	450		13,0	11,4	10,4	9,4	8,4	7,0	5,4	2,5	1,6
ARVEX/S 150 T	3 x 220V or 380V	1,9	1,1	1,5	3,4	---	---		13,0	11,4	10,4	9,4	8,4	7,0	5,4	2,5	1,6

PREVALENZA TOTALE IN METRI COLONNA ACQUA / TOTAL PUMP HEAD AND WATER COLUMN HEIGHT IN M.



**CARATTERISTICHE DI COSTRUZIONE:**

- ELETTOPOMPA A DOPPIA CAMERA (MOTORE, TENUTA MECCANICA).
  - MOTORE A BAGNO D'OLIO (BIODEGRADABILE E DIELETTRICO) PER RAFFREDDAMENTO E LUBRIFICAZIONE CUSCINETTI.
  - ANELLO DI TENUTA LATO MOTORE.
  - TENUTA MECCANICA A BAGNO D'OLIO.
  - IMMERSIONE MASSIMA: mt. 5.
  - GRADO DI PROTEZIONE IP 68.
  - CLASSE DI ISOLAMENTO: F
  - TEMPERATURA MAX. LIQUIDO POMPATO:  
25°C con pompa PARZIALMENTE immersa.  
35°C con pompa TOTALMENTE immersa.
  - PASSAGGIO LIBERO: 50 mm.
  - VERSIONI:  
Monofase: 220-277V/50Hz o 220-277V/60 Hz con protettore termico incorporato e condensatore permanentemente inserito.  
Trifase: 220-277V/50Hz o 380-480V/50Hz e 220-277V/60Hz o 380-480V/60Hz con protezione da sovraccarico a cura dell'utente.
  - VERSIONI MONOFASI AUTOMATICHE CON GALLEGGIANTE O MANUALI SENZA GALLEGGIANTE.
  - CAVO STANDARD:  
Monofase: 10 metri H05VV-F per versione normale (aut.-man.).  
Trifase: 10 metri H05VV-F
- SPECIALI VOLTAGGI E FREQUENZE A RICHIESTA.

**DESIGN ENGINEERING**

- DOUBLE CHAMBER ELECTRIC PUMP (MOTOR, MECHANICAL SEAL).
  - OIL BATH MOTOR (BIODEGRADABLE AND DIELECTRIC) FOR COOLING AND BEARING LUBRICATION.
  - SEALING RING - ENGINE FACE.
  - OIL BATH MECHANICAL SEALS.
  - PERMISSIBLE DRAUGHT OF WATER: 5 m.
  - IP 68 PROTECTION CLASS.
  - CLASS "F" INSULATION.
  - MAX. PUMPED LIQUID TEMPERATURE:  
25°C with PARTIALLY submerged pump.  
35°C with TOTALLY submerged pump.
  - BY PASS SECTION: 50 mm.
  - VERSIONS:  
Single Phase: 220-277V/50Hz or 220-277V/60 Hz with built in thermal protection and permanent capacitor.  
Three Phase: 220-277V/50Hz or 380-480V/50Hz and 220-277V/60Hz or 380-480V/60Hz with overload protection care of the User.
  - AUTOMATIC SINGLE PHASE VERSIONS WITH FLOATER OR MANUAL WITHOUT FLOATER.
  - STANDARD CABLE FEATURES:  
Single Phase: 10 metres H05VV-F for the standard version (automatic-manual).  
Three Phase: 10 metres H05VV-F
- CUSTOMISED VOLTAGE AND FREQUENCY RATING AVAILABLE ON DEMAND.

**TABELLA MATERIALI / MATERIALS TABLE:**

Pos.	Componente / Component		Materiale / Materials
A	Carcassa esterna / External housing		ACCIAIO INOX AISI 316 DIN 1.4401 STAINLESS STEEL
B	Girante / Impeller		
C	Albero (lato pompa) / Shaft (pump side)		
D	Tenuta meccanica Mechanical seal	Lato pompa / Pump face	CARBURO DI SILICIO-VITON SILICON CARBIDE-VITON
		Lato motore / Motor face	ANELLO DI TENUTA NBR NBR SEAL RING
E	O-ring		VITON
G	Porta motore / Motor holder		ACCIAIO INOX AISI 316 DIN 1.4401 STAINLESS STEEL
I	Coperchio + maniglia / Cover + handle		
N	Base d'appoggio / Base holder		
P	Corpo pompa / Pump body		

**ARVEX BC 100/S - 150/S - 200/S**

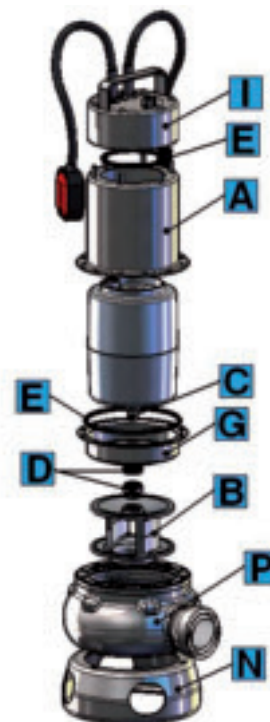



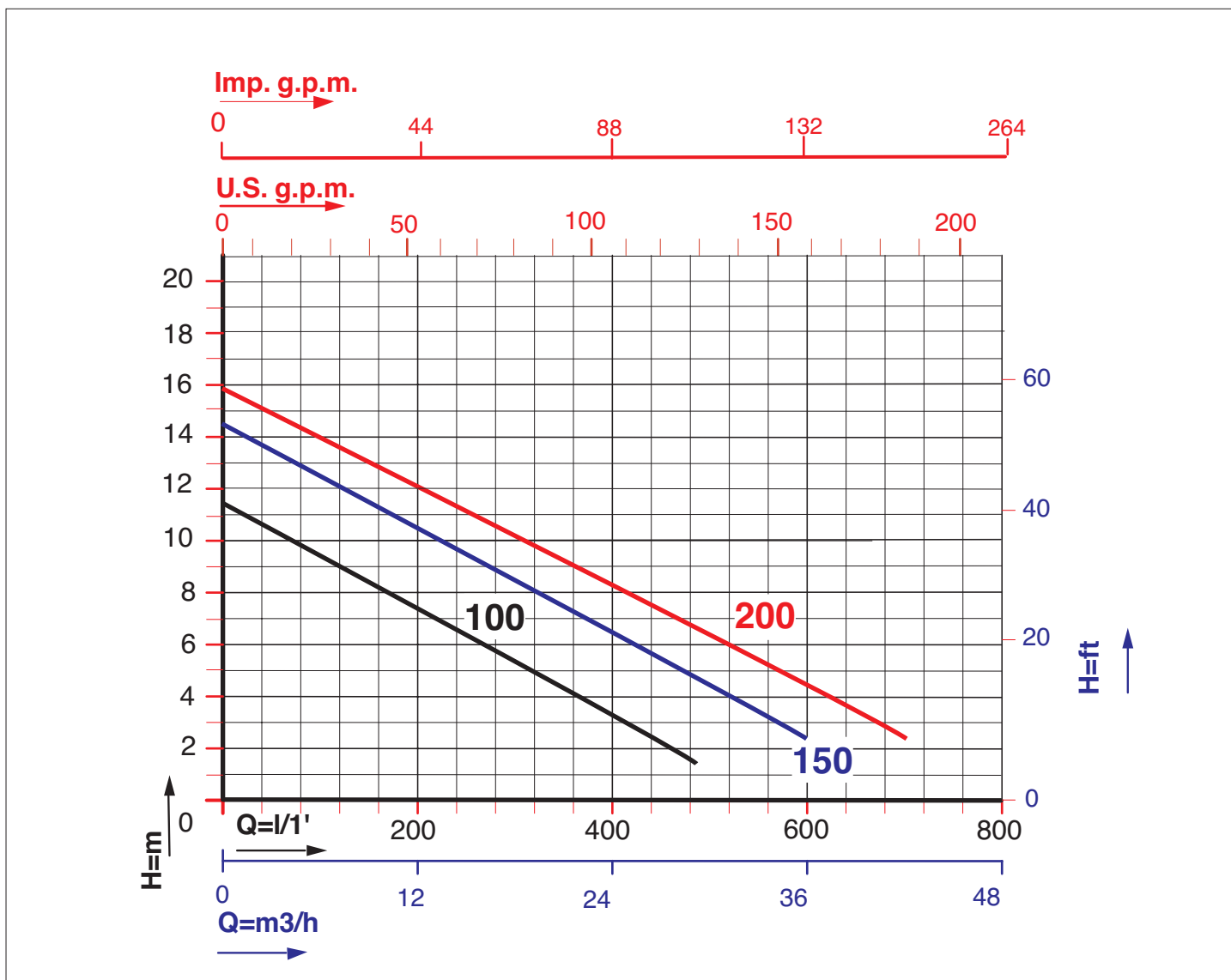

Caratteristiche di funzionamento a 2800 rpm 50Hz e 3450 rpm 60Hz - Performances at 2800 rpm 50 Hz and 3450 rpm 60 Hz  
 Le prestazioni valgono per liquidi con densità  $\rho = 1,0 \text{ kg/dm}^3$  ed una viscosità  $\nu = 1 \text{ mm}^2/\text{s}$  / The performance data holds true for liquids with a  $\rho = 1,0 \text{ kg/dm}^3$  density and a  $\nu = 1 \text{ mm}^2/\text{s}$  viscosity.

MODELLO MODEL	VOLTAGGIO VOLTAGE	DATI ELETTRICI / ELECTRICAL DATA						DATI IDRAULICI / HYDRAULIC DATA										
		P1max	P2 nom.	I max	Condensatore Capacitor		m³/h	0	3	6	12	18	24	30	36	42		
50Hz		kW	kW	HP	Ampere	µF	VC	l/min.	0	50	100	200	300	400	500	600	700	
ARVEX/S BC 100 M	1 x 220-230V	1,5	0,75	1,0	7,0	20	450	H (m)	11,5	10,5	9,5	7,5	5,5	3,5	1,5			
ARVEX/S BC 100 T	3 x 380V - 400V	1,3	0,75	1,0	3,2	---	---		11,5	10,5	9,5	7,5	5,5	3,5	1,5			
ARVEX/S BC 150 M	1 x 220-230V	2,2	1,1	1,5	11,5	30	450		14,5	13,5	12,5	10,5	8,5	6,5	4,5	2,5		
ARVEX/S BC 150 T	3 x 380V - 400V	1,7	1,1	1,5	4,5	---	---		14,5	13,5	12,5	10,5	8,5	6,5	4,5	2,5		
ARVEX/S BC 200 T	3 x 380V - 400V	2,2	1,5	2,0	4,8	---	---		16,0	14,8	14,0	12,0	10,5	8,2	6,5	4,3	2,5	

PREVALENZA TOTALE in METRI COLONNA  
ACQUA / TOTAL PUMP HEAD AND WATER  
COLUMN HEIGHT IN m.

**DIMENSIONI E PESI / SIZE AND WEIGHT DATA:**

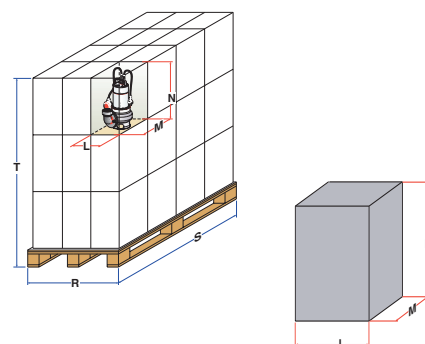
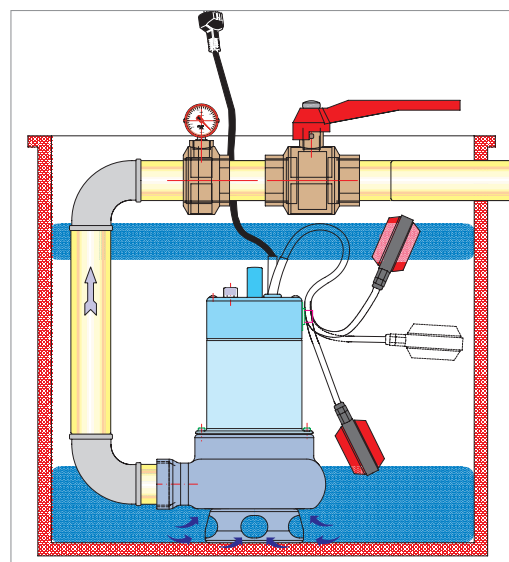
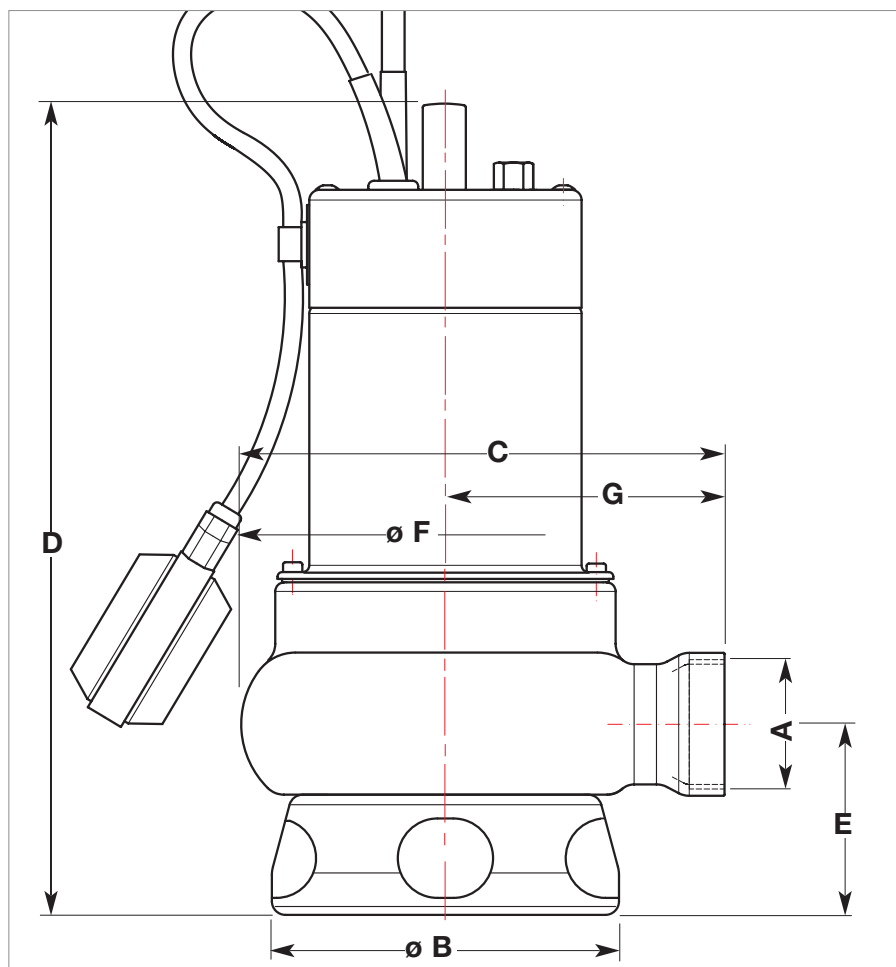

MODELLO MODEL	DIMENSIONI POMPA in mm. / PUMP DIMENSIONS in mm.						
	A	B	C	D	E	F	G
ARVEX/S 80 M	2"	176	214	358	88	180	124
ARVEX/S 80 T	2"	176	214	358	88	180	124
ARVEX/S 100 M	2"	176	214	358	88	180	124
ARVEX/S 100 T	2"	176	214	358	88	180	124
ARVEX/S 150 M	2"	176	214	398	88	180	124
ARVEX/S 150 T	2"	176	214	398	88	180	124
ARVEX/S BC 100	2"	176	214	369	88	180	124
ARVEX/S BC 150	2"	176	214	409	88	180	124
ARVEX/S BC 200	2"	176	214	409	88	180	124

MODELLO MODEL	DIMENSIONI SCATOLA / PACKING DIMENSIONS				DIMENSIONI PALLET / PALLET DIMENSIONS				
	L mm.	M mm.	N mm.	Peso / Weight Kg.	R mm.	S mm.	T mm.	nr. scatole/cartons	Peso / Weight Kg.
ARVEX/S 80 M	190	230	410	10,5	800	1200	1360	60	650
ARVEX/S 80 T	190	230	410	10,5	800	1200	1360	60	650
ARVEX/S 100 M	190	230	410	11,5	800	1200	1360	60	715
ARVEX/S 100 T	190	230	410	11,5	800	1200	1360	60	715
ARVEX/S 150 M	190	230	410	13,5	800	1200	1360	60	835
ARVEX/S 150 T	190	230	410	13,5	800	1200	1360	60	835
ARVEX/S BC 100	190	230	480	12,5	800	1200	1570	60	775
ARVEX/S BC 150	190	230	480	14,5	800	1200	1570	60	895
ARVEX/S BC 200	190	230	480	14,5	800	1200	1570	60	895

# ARVEX aisi 304



## **ELETTROPOMPE SOMMERGIBILI VORTEX E BICANALI PER ACQUE CARICHE SUBMERSIBLE VORTEX AND BICANAL ELECTRIC PUMPS FOR WASTEWATER**

**PREVALENZA** ..... : 9,5 m ÷ 16,0 m  
**PORTATA** ..... : 18,0 m<sup>3</sup>/h ÷ 42 m<sup>3</sup>/h  
**POTENZA NOMINALE** : 0,75 kW (1,0HP) ÷ 1,5 kW (2,0HP)  
**PASSAGGIO SOLIDI FINO A 50 mm.**

### **APPLICAZIONI**

- SVUOTAMENTO DI FOSSE DI DECANTAZIONE, POZZI NERI, POZZI DI RACCOLTA LIQUAMI.
- POMPAGGIO DI ACQUE LURIDE ANCHE CON CORPI SOLIDI IN SOSPENSIONE.
- MOVIMENTAZIONE DI ACQUE LURIDE AD USO DOMESTICO ED INDUSTRIALE.

**PUMP HEAD** ..... : 9,5 mt ÷ 16,0 mt  
**DELIVERY** ..... : 18,0 m<sup>3</sup>/h ÷ 42,0 m<sup>3</sup>/h  
**RATED HORSEPOWER** : 0,75 kW (1,0HP) ÷ 1,5 kW (2,0HP)  
**SOLID MATTER BYPASS up to 50 mm.**

### **APPLICATIONS**

- DECANTATION PIT, SEWAGE PIT AND SLURRY COLLECTION PIT PUMP OUT.
- PUMP OUT OF LAVATORY/FOUL WATER WITH POSSIBLE FLOATING SOLIDS CONTENTS.
- DOMESTIC AND INDUSTRIAL LAVATORY/BLACK WATER HANDLING SYSTEMS.

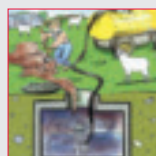
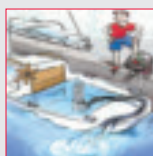
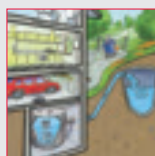

**ARVEN**

**CARATTERISTICHE DI COSTRUZIONE:**

- ELETTOPOMPA A DOPPIA CAMERA (MOTORE, TENUTA MECCANICA).
- MOTORE A BAGNO D'OLIO (BIODEGRADABILE E DIELETTRICO) PER RAFFREDDAMENTO E LUBRIFICAZIONE CUSCINETTI.
- ANELLO DI TENUTA LATO MOTORE.
- TENUTA MECCANICA A BAGNO D'OLIO.
- IMMERSIONE MASSIMA: mt. 5 .
- GRADO DI PROTEZIONE IP 68 .
- CLASSE DI ISOLAMENTO: F
- TEMPERATURA MAX. LIQUIDO POMPATO:  
25°C con pompa PARZIALMENTE immersa.  
35°C con pompa TOTALMENTE immersa.
- PASSAGGIO LIBERO: 40mm ARVEX 80  
50mm ARVEX 100-150-200
- VERSIONI:  
Monofase: 220-277V/50Hz o 220-277V/60Hz con protettore termico incorporato e condensatore permanentemente inserito.  
Trifase: 220-277V/50Hz o 380-480V/50Hz e 220-277V/60Hz o 380-480V/60Hz con protezione da sovraccarico a cura dell'utente.
- VERSIONI MONOFASI AUTOMATICHE CON GALLEGGIANTE O MANUALI SENZA GALLEGGIANTE.
- CAVO STANDARD:  
Monofase: 5 e 10 metri H07RN-F (aut.-man.).  
Trifase: 10 metri H07RN-F
- SPECIALI VOLTAGGI E FREQUENZE A RICHIESTA.

**OPTIONAL:**

- SISTEMI DI DISCESA (DN50) PER IMPIANTI FISSI (VEDERE PAGINA 100-101)

**DESIGN ENGINEERING:**

- DOUBLE CHAMBER ELECTRIC PUMP (MOTOR, MECHANICAL SEAL).
- OIL BATH MOTOR (BIODEGRADABLE AND DIELECTRIC) FOR COOLING AND BEARING LUBRICATION.
- SEALING RING - ENGINE FACE.
- OIL BATH MECHANICAL SEALS.
- PERMISSIBLE DRAUGHT OF WATER: 5 m
- IP 68 PROTECTION CLASS.
- CLASS "F" INSULATION.
- MAX. PUMPED LIQUID TEMPERATURE:  
25°C with PARTIALLY submerged pump.  
35°C with TOTALLY submerged pump.
- BY PASS SECTION: 40mm ARVEX 80  
50mm ARVEX 100-150-200
- VERSIONS:  
Single Phase: 220-277V/50Hz or 220-277V/60Hz with built in thermal protection and permanent capacitor.  
Three Phase: 220-277V/50Hz or 380-480V/50Hz and 220-277V/60Hz or 380-480V/60Hz with overload protection care of the User.
- AUTOMATIC SINGLE PHASE VERSIONS WITH FLOATER OR MANUAL WITHOUT FLOATER.
- STANDARD CABLE FEATURES:  
Single Phase: 5 and 10 metres H07RN-F for the standard version (automatic-manual).  
Three Phase: 10 metres H07RN-F
- CUSTOMISED VOLTAGE AND FREQUENCY RATING AVAILABLE ON DEMAND.

**OPTIONAL:**

- DOWN STROKE GUIDE RAIL SYSTEMS (DN50) FOR FIXED PLANTS (SEE PAGE 100-101)

**TABELLA MATERIALI / MATERIALS TABLE:**

Pos.	Componente / Component		Materiale / Materials
A	Carcassa esterna / External housing		ACCIAIO INOX AISI 304 DIN 1.4301 STAINLESS STEEL
B	Girante / Impeller		
C	Albero (lato pompa) / Shaft (pump side)		ACCIAIO INOX AISI 316 DIN 1.4401 STAINLESS STEEL
D	Tenuta meccanica Mechanical seal	Lato pompa/ Pump side	GRAFITE-CERAMICA GRAPHITE-CERAMIC
		Lato motore/ motor side	ANELLO DI TENUTA NBR NBR SEAL RING
E	O-ring		NBR
G	Porta motore / Motor holder		ACCIAIO INOX AISI 304 DIN 1.4301 STAINLESS STEEL
I	Coperchio + maniglia / Cover + handle		
N	Base d'appoggio / Base holder		
P	Corpo pompa / Pump body		

**ARVEX 80- 100 - 150 - 200**

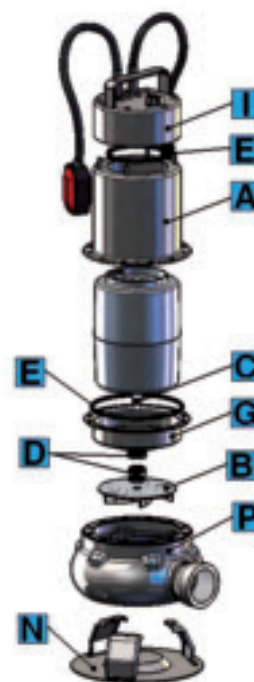

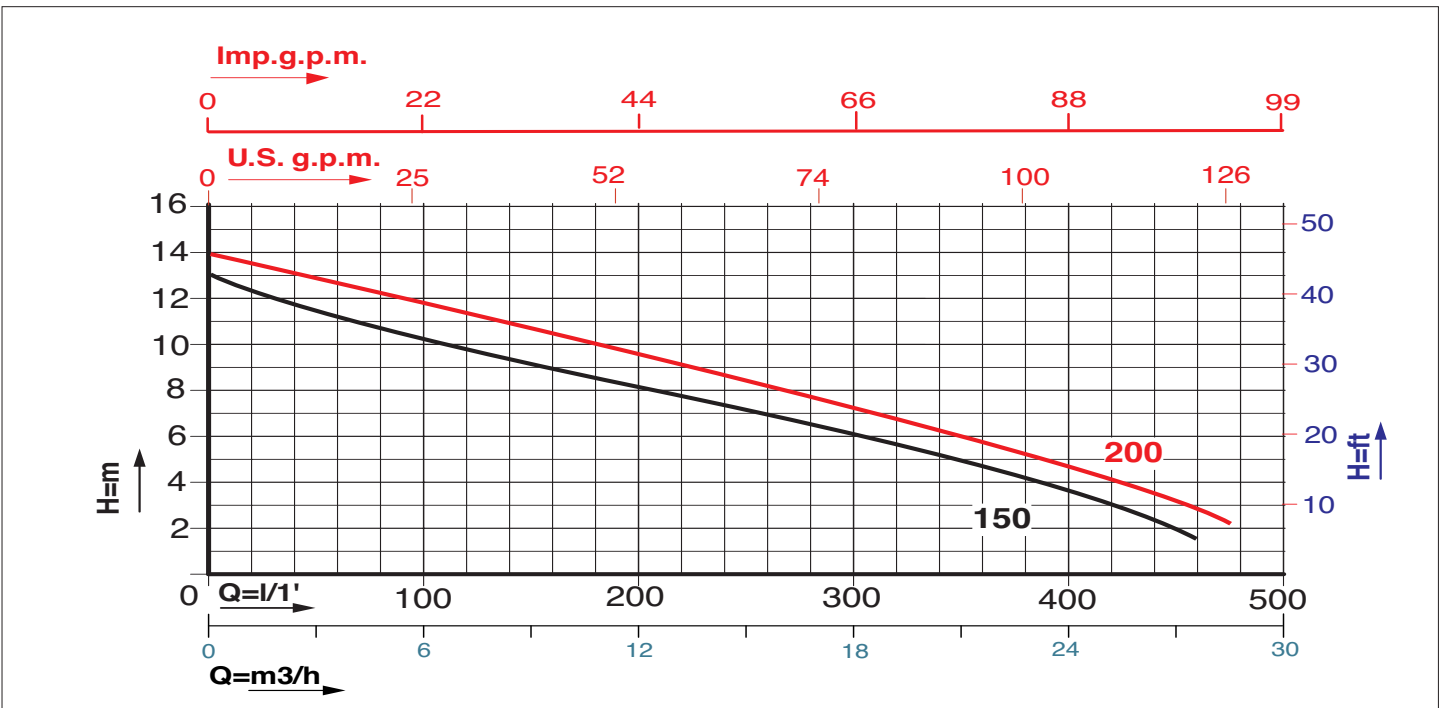
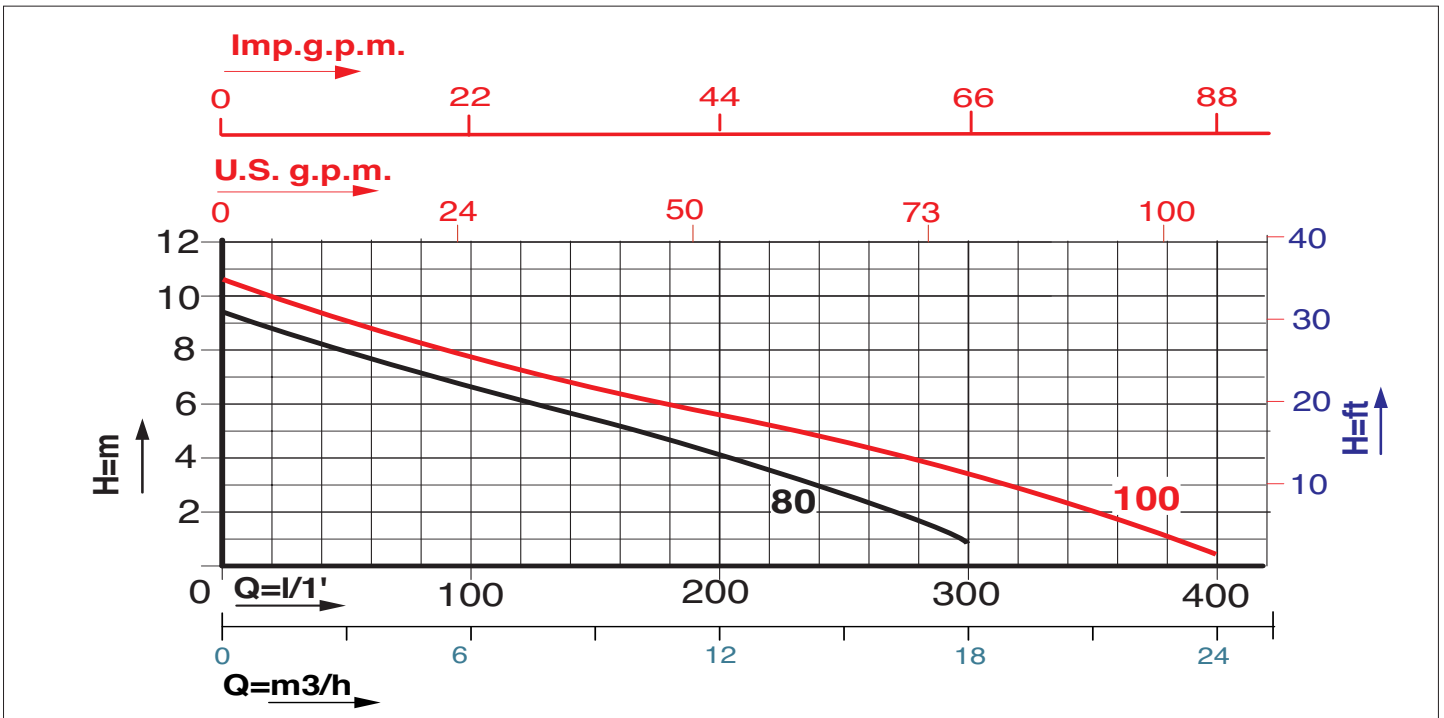

Caratteristiche di funzionamento a 2800 rpm 50Hz e 3450 rpm 60Hz - Performances at 2800 rpm 50 Hz and 3450 rpm 60 Hz  
 Le prestazioni valgono per liquidi con densità  $\rho = 1,0 \text{ kg/dm}^3$  ed una viscosità  $\nu = 1 \text{ mm}^2/\text{s}$  / The performance data holds true for liquids with a  $\rho = 1,0 \text{ kg/dm}^3$  density and a  $\nu = 1 \text{ mm}^2/\text{s}$  viscosity.

MODELLO MODEL	VOLTAGGIO VOLTAGE 50Hz	DATI ELETTRICI / ELECTRICAL DATA						DATI IDRAULICI / HYDRAULIC DATA										
		P1max kW	P2 nom. kW	HP	I max Ampere	Condensatore Capacitor $\mu\text{F}$	VC	m <sup>3</sup> /h	0	3	6	9	12	15,6	18	24	25,5	27,0
ARVEX 80 M	1 x 220-240V	1,1	0,6	0,8	5,1	16	450	l/min.	0	50	100	150	200	260	300	400	425	450
ARVEX 80 T	3 x 380V - 400V	0,9	0,6	0,8	2,1	---	---	H (m)	9,5	8,0	6,7	5,5	4,2	2,4	0,6			
ARVEX 100 M	1 x 220-240V	1,5	0,75	1,0	6,5	20	450	PRELIEVO TOTALE IN METRI COLONNA ACQUA / TOTAL PUMP HEAD AND WATER COLUMN HEIGHT IN m.	10,5	8,6	7,6	6,6	5,4	4,4	3,2	0,6		
ARVEX 100 T	3 x 380V - 400V	1,3	0,75	1,0	2,6	---	---		10,5	8,6	7,6	6,6	5,4	4,4	3,2	0,6		
ARVEX 150 M	1 x 220-240V	2,2	1,1	1,5	10,4	30	---		13,0	11,4	10,4	9,4	8,4	7,0	5,4	2,5	1,6	
ARVEX 150 T	3 x 380V - 400V	1,7	1,1	1,5	3,3	---	---		13,0	11,4	10,4	9,4	8,4	7,0	5,4	2,5	1,6	
ARVEX 200 M	1 x 220V - 240V	2,4	1,5	2,0	11,5	30	450		14,0	13,0	12,0	10,8	9,8	8,4	7,4	4,0	3,4	2,4
ARVEX 200 T	3 x 380V - 400V	2,2	1,5	2,0	3,7	---	---		14,0	13,0	12,0	10,8	9,8	8,4	7,4	4,0	3,4	2,4



**CARATTERISTICHE DI COSTRUZIONE:**

- ELETTOPOMPA A DOPPIA CAMERA (MOTORE, TENUTA MECCANICA).
- MOTORE A BAGNO D'OLIO (BIODEGRADABILE E DIELETTRICO) PER RAFFREDDAMENTO E LUBRIFICAZIONE CUSCINETTI.
- ANELLO DI TENUTA LATO MOTORE.
- TENUTA MECCANICA A BAGNO D'OLIO.
- IMMERSIONE MASSIMA: mt. 5 .
- GRADO DI PROTEZIONE IP 68 .
- CLASSE DI ISOLAMENTO: F
- TEMPERATURA MAX. LIQUIDO POMPATO:  
25°C con pompa PARZIALMENTE immersa.  
35°C con pompa TOTALMENTE immersa.
- PASSAGGIO LIBERO: 50 mm
- VERSIONI:  
Monofase: 220-277V / 50Hz o 220 - 277V/ 60Hz con protettore termico incorporato e condensatore permanentemente inserito.  
Trifase: 220 - 277V/ 50Hz o 380-480V/50 Hz e 220 - 277V/ 60Hz o 380 - 480V/ 60Hz con protezione da sovraccarico a cura dell'utente.
- VERSIONI MONOFASI AUTOMATICHE CON GALLEGGIANTE O MANUALI SENZA GALLEGGIANTE.
- CAVO STANDARD:  
Monofase: 10 metri H07RN-F (automatico - manuale).  
Trifase: 10 metri H07RN-F
- SPECIALI VOLTAGGI E FREQUENZE A RICHIESTA

**OPTIONAL:**

- SISTEMI DI DISCESA DN50 PER IMPIANTI FISSI (VEDERE PAGINA 100)

**DESIGN ENGINEERING:**

- DOUBLE CHAMBER ELECTRIC PUMP (MOTOR, MECHANICAL SEAL).
- OIL BATH MOTOR (BIODEGRADABLE AND DIELECTRIC) FOR COOLING AND BEARING LUBRICATION.
- SEALING RING - ENGINE FACE
- OIL BATH MECHANICAL SEALS.
- PERMISSIBLE DRAUGHT OF WATER: 5 m
- IP 68 PROTECTION CLASS.
- CLASS "F" INSULATION.
- MAX. PUMPED LIQUID TEMPERATURE:  
25°C with PARTIALLY submerged pump.  
35°C with TOTALLY submerged pump.
- BY PASS SECTION: 50 mm
- VERSIONS:  
Single Phase: 220 – 277V / 50Hz or 220 – 277V / 60 Hz with built in thermal protection and permanent capacitor.  
Three Phase: 220-277V/50 Hz or 380 – 480V / 50Hz and 220- 277V or 380 - 480V / 60Hz with overload protection care of the User.
- AUTOMATIC SINGLE PHASE VERSIONS WITH FLOATER OR MANUAL WITHOUT FLOATER.
- STANDARD CABLE FEATURES:  
Single Phase: 10 metres H07RN-F (automatic-manual).  
Three Phase: 10 metres H07RN-F
- CUSTOMISED VOLTAGE AND FREQUENCY RATING AVAILABLE ON DEMAND.

**OPTIONAL:**

- DOWN STROKE GUIDE RAIL SYSTEMS DN50 FOR FIXED PLANTS (SEE PAGE 100)

**TABELLA MATERIALI / MATERIALS TABLE:**

Pos.	Componente / Component		Materiale / Materials
A	Carcassa esterna / External housing		ACCIAIO INOX AISI 304 DIN 1.4301 STAINLESS STEEL
B	Girante / Impeller		ACCIAIO INOX AISI 316 DIN 1.4401 STAINLESS STEEL
C	Albero (lato pompa) / Shaft (pump side)		
D	Tenuta meccanica Mechanical seal	Lato pompa/ Pump side	GRAFITE - CERAMICA GRAPHITE - CERAMIC
		Lato motore/ motor side	ANELLO DI TENUTA NBR NBR SEAL RING
E	O-ring		NBR
G	Porta motore / Motor holder		ACCIAIO INOX AISI 304 DIN 1.4301 STAINLESS STEEL
I	Coperchio + maniglia / Cover + handle		
N	Base d'appoggio / Base holder		
P	Corpo pompa / Pump body		

ARVEX - BC 100 - 150 - 200

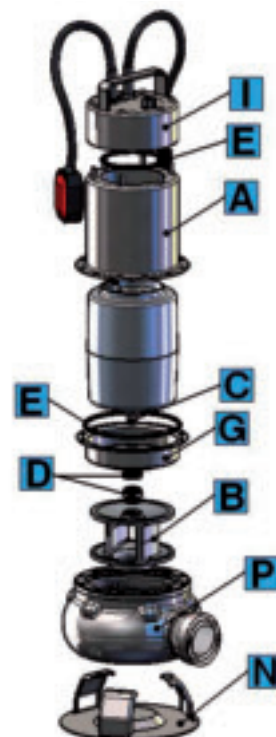

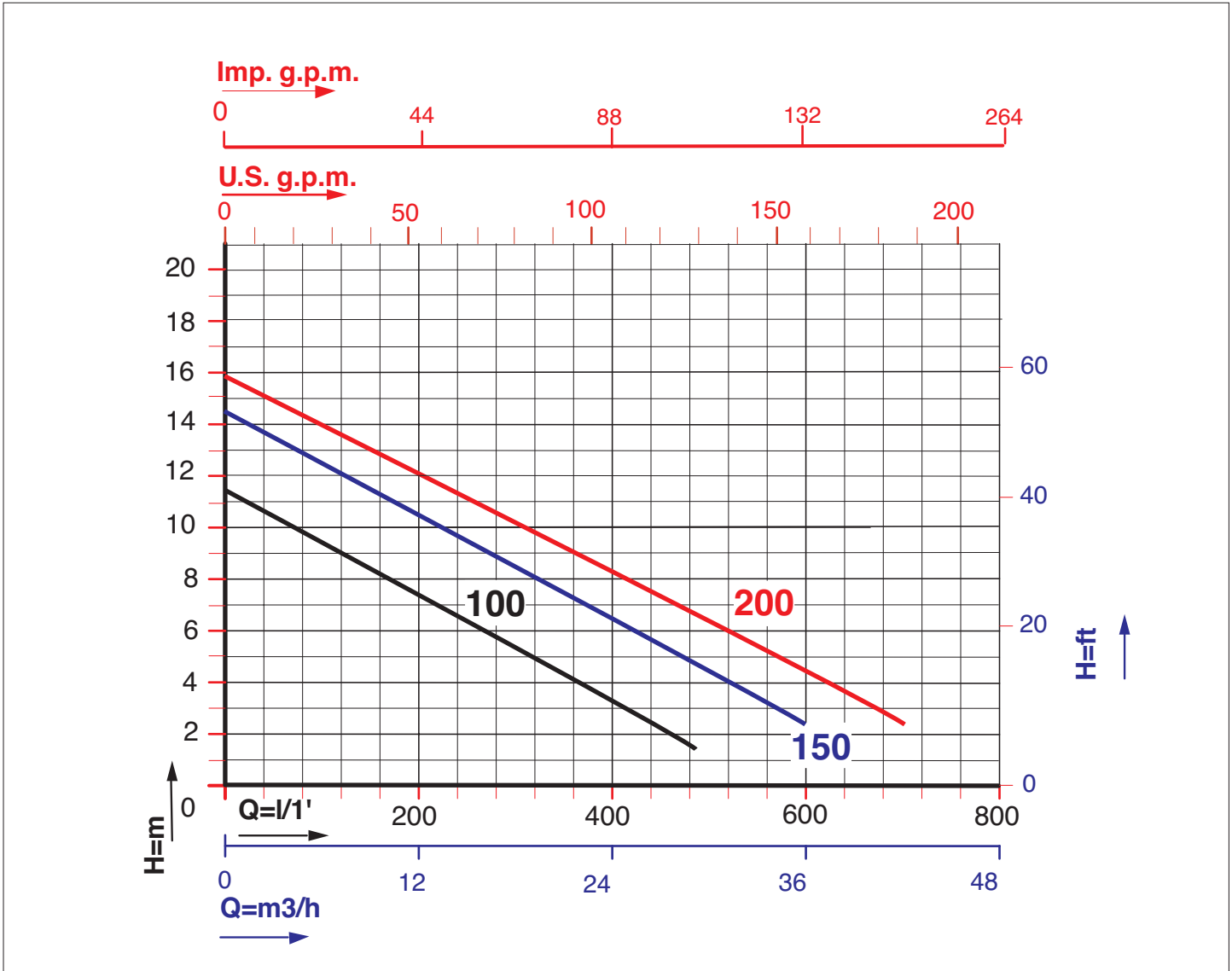

Caratteristiche di funzionamento a 2800 rpm 50Hz e 3450 rpm 60Hz - Performances at 2800 rpm 50 Hz and 3450 rpm 60 Hz  
 Le prestazioni valgono per liquidi con densità  $\rho = 1,0 \text{ kg/dm}^3$  ed una viscosità  $\nu = 1 \text{ mm}^2/\text{s}$  / The performance data holds true for liquids with a  $\rho = 1,0 \text{ kg/dm}^3$  density and a  $\nu = 1 \text{ mm}^2/\text{s}$  viscosity.

MODELLO MODEL	VOLTAGGIO VOLTAGE	DATI ELETTRICI / ELECTRICAL DATA						DATI IDRAULICI / HYDRAULIC DATA										
		P1 max	P2 nom.	I max	Condensatore Capacitor		m³/h	0	3	6	12	18	24	30	36	42		
50Hz		kW	kW	HP	Ampere	µF	VC	l/min.	0	50	100	200	300	400	500	600	700	
ARVEX BC 100 M	1 x 220-230V	1,5	0,75	1,0	7,0	20	450	H (m)	11,5	10,5	9,5	7,5	5,5	3,5	1,5			
ARVEX BC 100 T	3 x 380V - 400V	1,3	0,75	1,0	3,2	---	---		11,5	10,5	9,5	7,5	5,5	3,5	1,5			
ARVEX BC 150 M	1 x 220-230V	2,2	1,1	1,5	11,5	30	450		14,5	13,5	12,5	10,5	8,5	6,5	4,5	2,5		
ARVEX BC 150 T	3 x 380V - 400V	1,7	1,1	1,5	4,5	---	---		14,5	13,5	12,5	10,5	8,5	6,5	4,5	2,5		
ARVEX BC 200 T	3 x 380V - 400V	2,2	1,5	2,0	4,8	---	---		16,0	14,8	14,0	12,0	10,5	8,2	6,5	4,3	2,5	

PREVALENZA TOTALE in METRI COLONNA ACQUA / TOTAL PUMP HEAD AND WATER COLUMN HEIGHT IN m.

**DIMENSIONI e PESI / SIZE AND WEIGHT DATA:**

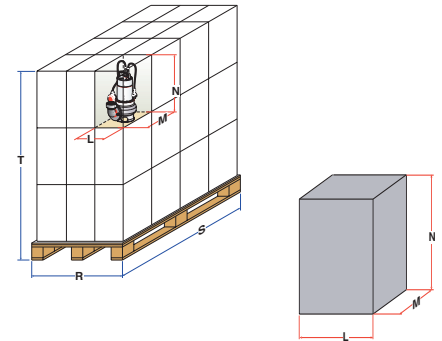
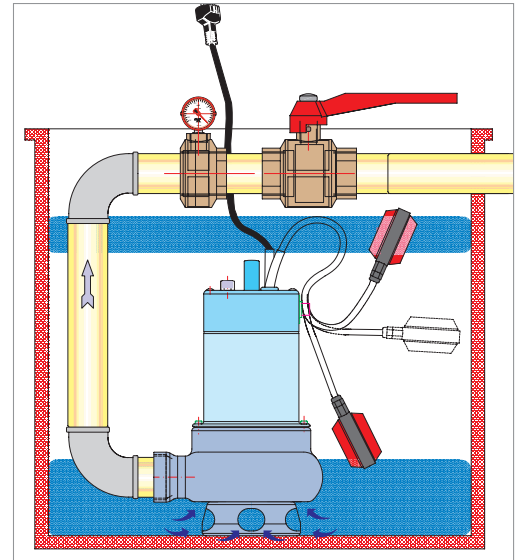
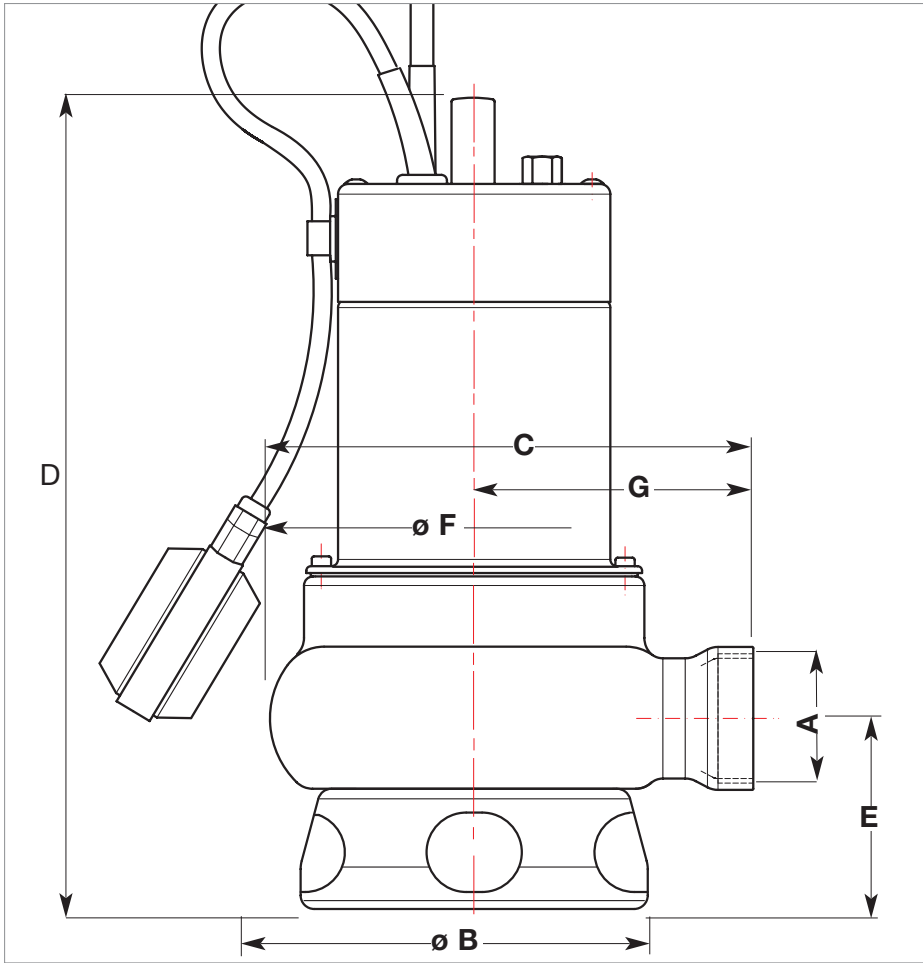

MODELLO MODEL	DIMENSIONI POMPA in mm. / PUMP DIMENSIONS in mm.						
	A	B	C	D	E	F	G
ARVEX 80	1" 1/2	180	214	358	88	180	124
ARVEX 100	2"	180	214	358	88	180	124
ARVEX 150	2"	180	214	398	88	180	124
ARVEX 200	2"	180	214	398	88	180	124
ARVEX BC 100	2"	180	214	369	88	180	124
ARVEX BC 150	2"	180	214	409	88	180	124
ARVEX BC 200	2"	180	214	409	88	180	124

MODELLO MODEL	DIMENSIONI SCATOLA / PACKING DIMENSIONS				DIMENSIONI PALLET / PALLET DIMENSIONS				
	L mm.	M mm.	N mm.	Peso / Weight Kg.	R mm.	S mm.	T mm.	nr. scatole/cartons	Peso / Weight Kg.
ARVEX 80	190	230	410	10,5	800	1200	1360	60	650
ARVEX 100	190	230	410	11,5	800	1200	1360	60	715
ARVEX 150	190	230	480	13,5	800	1200	1570	60	835
ARVEX 200	190	230	480	13,5	800	1200	1570	60	835
ARVEX BC 100	190	230	480	12,5	800	1200	1570	60	775
ARVEX BC 150	190	230	480	14,5	800	1200	1570	60	895
ARVEX BC 200	190	230	480	14,5	800	1200	1570	60	895

# RIVER



## **ELETTROPOMPE SOMMERSIBILI MONOCANALI PER ACQUE CARICHE DOTATE DI CONTROFLANGIA SUBMERSIBLE SINGLE CHANNEL ELECTRIC PUMP FOR VERY FOUL WASTE WATER, FEATURING A COUNTER FLANGE**

**PREVALENZA** ..... : 10,5 mt. ÷ 30,5 mt.  
**PORTATA** ..... : 30 m<sup>3</sup>/h ÷ 96 m<sup>3</sup>/h  
**POTENZA NOMINALE** : 1,1 kW (1,5HP) ÷ 4,5 kW (6,0HP)  
**PASSAGGIO SOLIDI FINO A 60 mm.**

**PUMP HEAD** ..... : 10,5 mt ÷ 30,5 mt  
**DELIVERY** ..... : 30,0 m<sup>3</sup>/h ÷ 96,0 m<sup>3</sup>/h  
**RATED HORSEPOWER** : 1,1 kW (1,5HP) ÷ 4,5 kW (6,0HP)  
**SOLID MATTER BYPASS up to 60 mm**

### **APPLICAZIONI**

- SVUOTAMENTO DI FOSSE DI DECANTAZIONE, POZZI DI RACCOLTA LIQUAMI.
- POMPAGGIO DI ACQUE LURIDE ANCHE CON CORPI SOLIDI E PARTI FIBROSE IN SOSPENSIONE.
- MOVIMENTAZIONE DI ACQUE LURIDE AD USO DOMESTICO E INDUSTRIALE

### **APPLICATIONS**

- DECANTATION PIT, SLURRY COLLECTION PIT PUMP OUT.
- LAVATORY/FOUL WATER WITH FLOATING/NON-FLOATING SOLIDS AND FIBRE SUSPENSIDS PUMP OUT.
- DOMESTIC AND INDUSTRIAL LAVATORY/BLACK WATER HANDLING SYSTEMS.

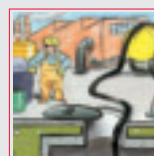
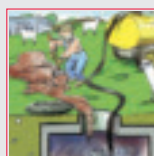
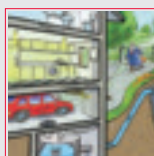

**AV ARVEN**

**CARATTERISTICHE DI COSTRUZIONE:**

- ELETTOPOMPA A DOPPIA CAMERA (MOTORE TENUTA MECCANICA).
- ELETTOPOMPA A UNICA CAMERA (SOLO PER RIVER 300F - 600F)
- MOTORE A BAGNO D'OLIO (BIODEGRADABILE E DIELETTRICO) PER RAFFREDDAMENTO E LUBRIFICAZIONE CUSCINETTI.
- ANELLO DI TENUTA LATO MOTORE.
- TENUTA MECCANICA A BAGNO D'OLIO.
- DOPPIA TENUTA MECCANICA (SOLO RIVER 300F - 600F):  
LATO MOTORE A BAGNO D'OLIO  
LATO POMPA IN BAGNO D'ACQUA

- IMMERSIONE MASSIMA: mt. 5.
- GRADO DI PROTEZIONE IP 68.
- CLASSE DI ISOLAMENTO: F
- TEMPERATURA MAX. LIQUIDO POMPATO:  
25°C con pompa PARZIALMENTE immersa.  
35°C con pompa TOTALMENTE immersa.

- PASSAGGIO LIBERO: 50 mm - RIVER 150F **a** (monocanale aperta)  
60 mm - RIVER 200F **a** (monocanale aperta)  
50 mm - RIVER 300F **c** (monocanale chiusa)  
50 mm - RIVER 400F **c** (monocanale chiusa)  
50 mm - RIVER 600F **c** (monocanale chiusa)

- VERSIONI: Monofase: 220-277V/50Hz o 220-277V/60Hz con protettore termico incorporato e condensatore permanentemente inserito.  
Trifase: 220-277V/50Hz o 220-277V/60Hz e 380-480V/50Hz con protezione da sovraccarico a cura dell'utente.
- POTENZA MOTORE: DA 1,5 Hp a 2 Hp VERSIONI MONOFASE E TRIFASE.  
DA 3 Hp a 6 Hp solo VERSIONI TRIFASE.
- VERSIONI MONOFASI AUTOMATICHE CON GALLEGGIANTE fino a 1,5 HP.  
VERSIONI MONOFASI da 2 Hp solo MANUALI SENZA GALLEGGIANTE.
- CAVO STANDARD: Monofase: 10 metri H07RN-F per versione normale (aut.-man).  
Trifase: 10 metri H07RN-F

SPECIALI VOLTAGGI E FREQUENZE A RICHIESTA.

**OPTIONAL:**

- SISTEMI DI DISCESA DN80 PER IMPIANTI FISSI (VEDERE PAGINA 100-101)

**DESIGN ENGINEERING:**

- DOUBLE CHAMBER ELECTRIC PUMP (MOTOR, MECHANICAL SEAL).
- SINGLE CHAMBER ELECTRIC PUMP (ONLY FOR RIVER 300F - 600F)
- OIL BATH MOTOR (BIODEGRADABLE AND DIELECTRIC) FOR COOLING AND BEARING LUBRICATION.
- SEALING RING - ENGINE FACE.
- OIL BATH MECHANICAL SEALS.
- DOUBLE MECHANICAL SEALS (ONLY FOR RIVER 300F - 600F):  
ENGINE FACE: OIL BATH  
PUMP FACE: WATER BATH.

- PERMISSIBLE DRAUGHT OF WATER: 5 m
- IP 68 PROTECTION CLASS.
- CLASS "F" INSULATION.
- MAX. PUMPED LIQUID TEMPERATURE:  
25°C with PARTIALLY submerged pump.  
35°C with TOTALLY submerged pump.

- BY PASS SECTION: 50 mm - RIVER 150F **a** (open single channel)  
60 mm - RIVER 200F **a** (open single channel)  
50 mm - RIVER 300F **c** (close single channel)  
50 mm - RIVER 400F **c** ((close single channel)  
50 mm - RIVER 600F **c** (close single channel)

- VERSIONS: Single Phase: 220-277V/50Hz with built in thermal protection and permanent capacitor.  
Three Phase: 220-277V/50Hz or 220-277V/60Hz and 380-480V/50Hz with overload protection care of the User.
- MOTOR POWER: From 1,5HP to 2HP SINGLE PHASE & THREE PHASE VERSIONS  
From 3HP to 6HP Only THREE PHASE VERSIONS.
- AUTOMATIC SINGLE PHASE VERSIONS up to 1,5 HP.  
SINGLE PHASE VERSIONS from 2 HP only manual, without floater.
- STANDARD CABLE FEATURES:  
Single Phase: 10 metres H07RN-F for the standard version (automatic-manual).  
Three Phase: 10 metres H07RN-F

CUSTOMISED VOLTAGE AND FREQUENCY RATING AVAILABLE ON DEMAND

**OPTIONAL:**

- DOWN STROKE GUIDE RAIL SYSTEMS DN80 FOR FIXED PLANTS (SEE PAGE 100-101 )

**TABELLA MATERIALI / MATERIALS TABLE:**

Pos.	Componente / Component	Materiale / Materials	
A	Carcassa esterna / External housing	ACCIAIO INOX AISI 304 DIN 1.4301 / STAINLESS STEEL	
B	Girante / Impeller	GHISA (G20)/CAST IRON	
C	Albero (lato pompa) / Pump body	ACCIAIO INOX AISI 316 DIN 1.4401 STAINLESS STEEL	
D	Tenuta meccanica Mechanical seal	Lato pompa / Pump side	CARBURO DI SILICIO-CERAMICA SILICON CARBIDE - CERAMIC
		Lato motore per Motor side for	RIVER 300F-600F GRAFITE-CERAMICA CARBIDE-CERAMIC
		RIVER 150F-200F ANELLO DI TENUTA NBR NBR SEAL RING	
E	O-ring	NBR	
G	Porta motore / Motor holder	RIVER 150F-200F	
H	Carcassa motore / Motor housing	RIVER 300F-600F	
I	Coperchio + maniglia / Cover + handle	ACCIAIO INOX AISI 304 DIN 1.4301 STAINLESS STEEL	
N	Base d'appoggio / Grid holder		
P	Corpo pompa / Pump body		
R	Flangia portamotore inferiore / Lower motor-flange	GHISA (G20) CAST IRON	
S	Flangia portamotore superiore / Upper motor-flange		
T	Controflangia d'aspirazione / Suction counter-flange	ACCIAIO INOX AISI 304 DIN 1.4301 STAINLESS STEEL	

RIVER 150F ÷ 200F

RIVER 300F ÷ 600F

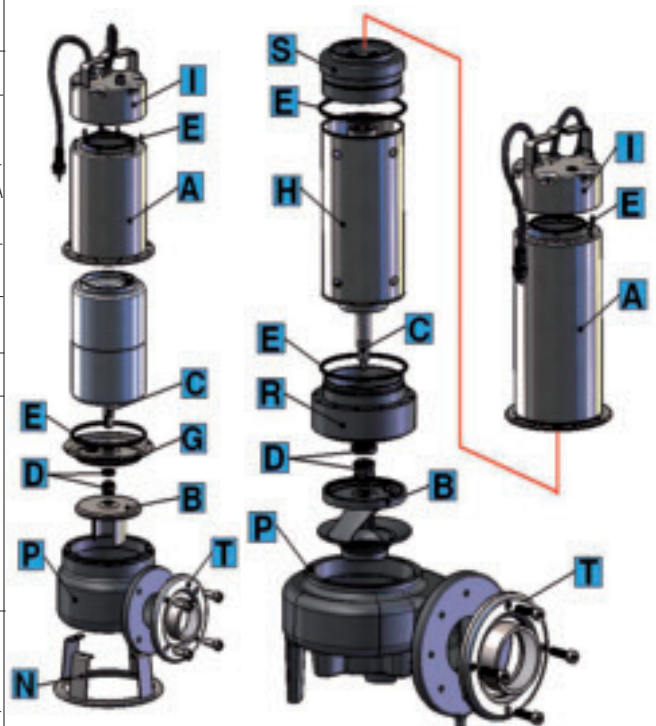



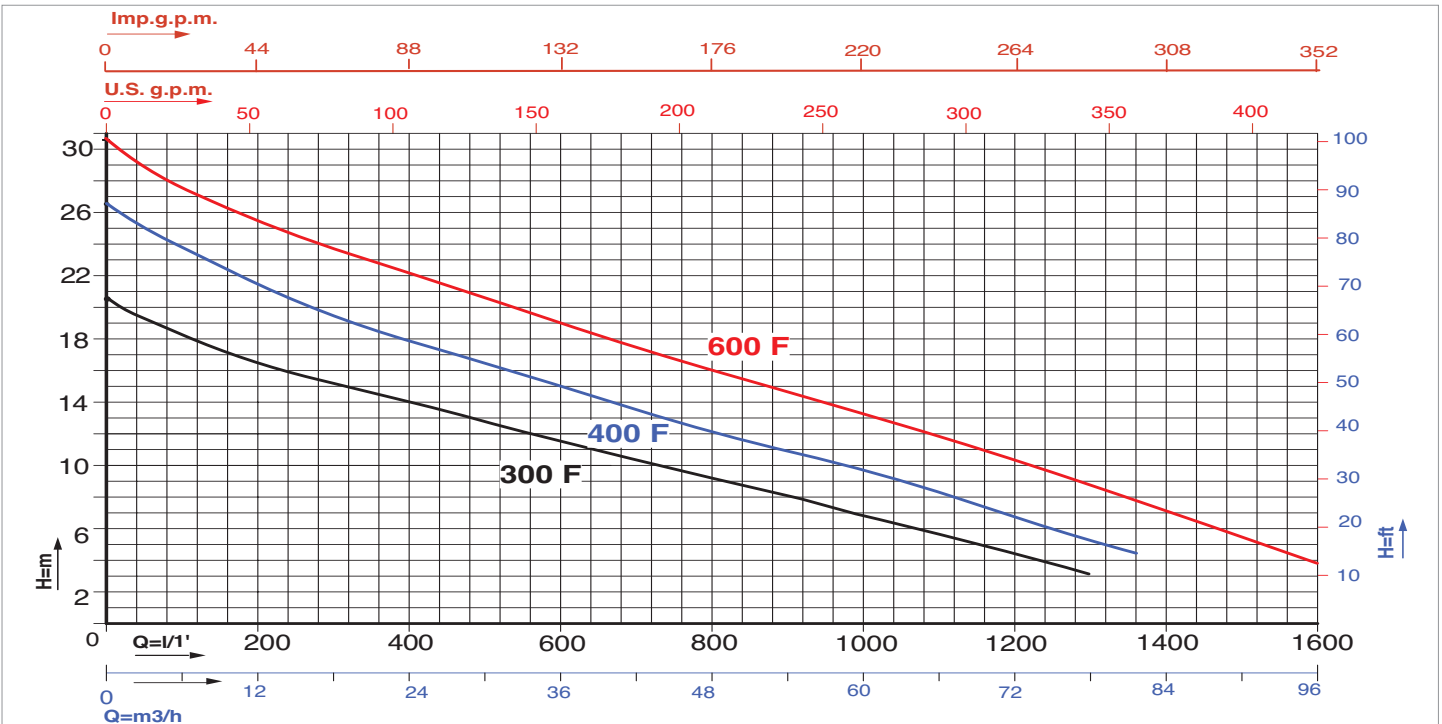
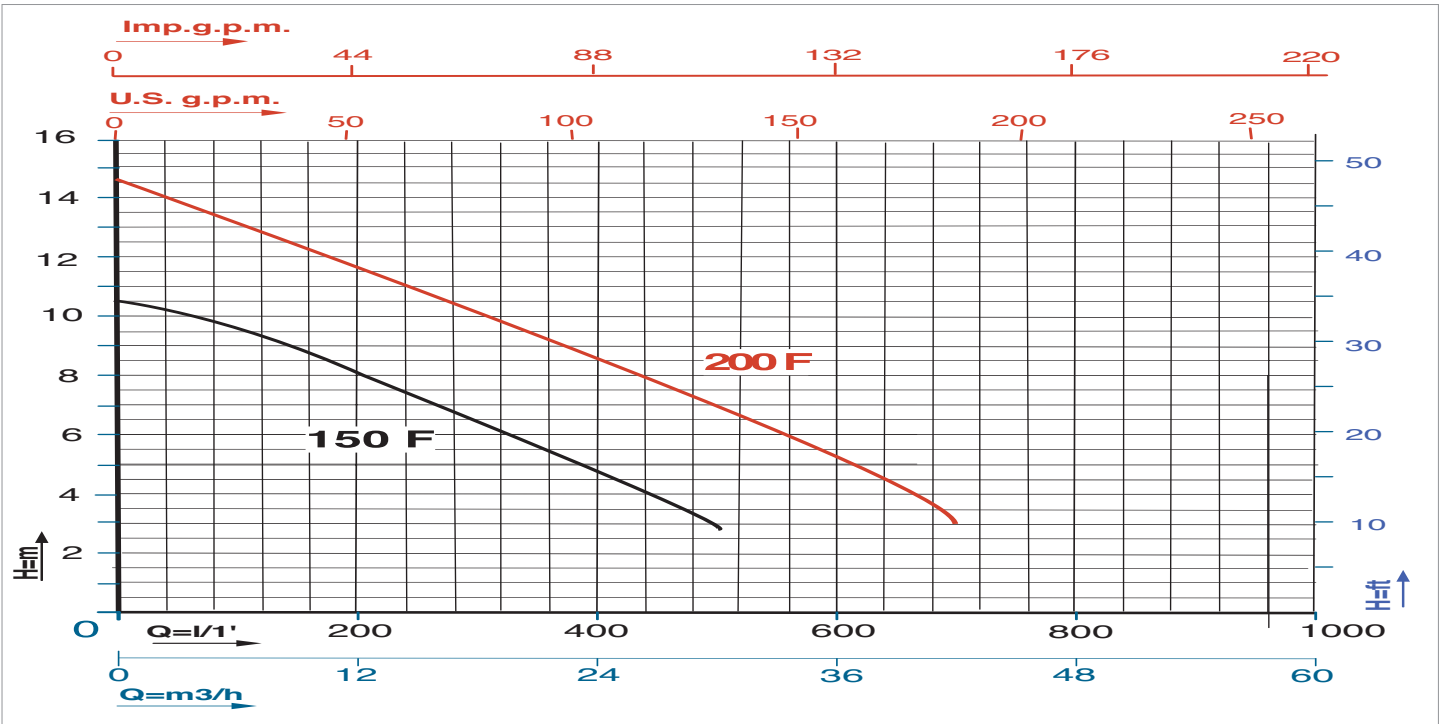

Caratteristiche di funzionamento a 2800 rpm 50Hz e 3450 rpm 60Hz - Performances at 2800 rpm 50 Hz and 3450 rpm 60 Hz  
 Le prestazioni valgono per liquidi con densità  $\rho = 1,0 \text{ kg/dm}^3$  ed una viscosità  $\nu = 1 \text{ mm}^2/\text{s}$  / The performance data holds true for liquids with a  $\rho = 1,0 \text{ kg/dm}^3$  density and a  $\nu = 1 \text{ mm}^2/\text{s}$  viscosity.

MODELLO MODEL	VOLTAGGIO VOLTAGE	DATI ELETTRICI / ELECTRICAL DATA						DATI IDRAULICI / HYDRAULIC DATA													
		P1 max kW	P2 nom. kW	I max HP	I max Ampere	Condensatore Capacitor		m³/h l/min.	H (m)												
						µF	VC		0	3	15	30	39	57	75	81	96				
RIVER 150F a M	1 x 220 - 240V	2,1	1,1	1,5	9,0	40	450	10,5	9,7	6,6	2,8										
RIVER 150F a T	3 x 380V - 400V	1,8	1,1	1,5	3,2	---	---	10,5	9,7	6,6	2,8										
RIVER 200F a M	1 x 220 - 240V	2,9	1,5	2,0	13,0	50	450	14,6	13,7	10,2	5,7	3,0									
RIVER 200F a T	3 x 380V - 400V	2,6	1,5	2,0	4,6	---	---	14,6	13,7	10,2	5,7	3,0									
RIVER 300F c T	3 x 380V - 400V	3,4	2,25	3,0	6,9	---	---	20,5	18,6	15,2	12,2	10,5	6,9	3,8							
RIVER 400F c T	3 x 380V - 400V	4,0	3,0	4,0	8,1	---	---	26,5	25,0	20,5	16,5	14,3	10,4	6,0	4,6						
RIVER 600F c T	3 x 380V - 400V	5,5	4,5	6,0	9,5	---	---	30,5	28,7	24,4	20,4	18,0	13,8	9,4	7,8	3,7					

**DIMENSIONI e PESI / SIZE AND WEIGHT DATA:**

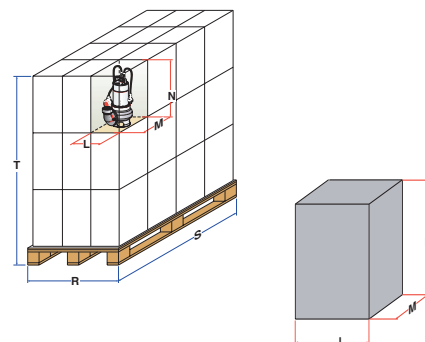
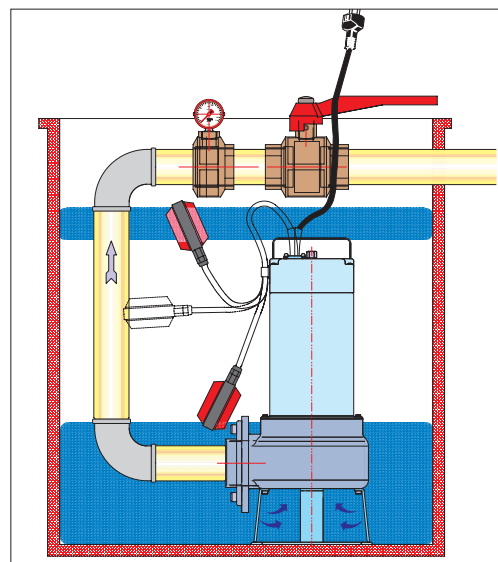
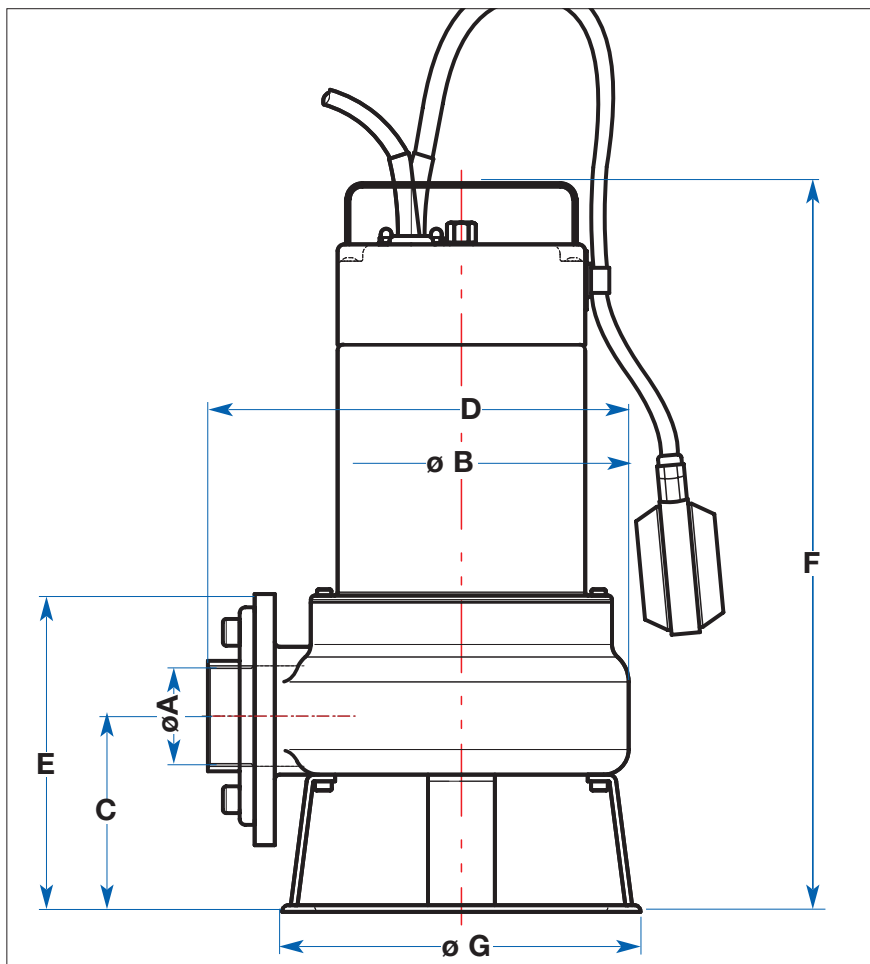

MODELLO MODEL	DIMENSIONI POMPA in mm. / PUMP DIMENSIONS in mm.						
	A	B	C	D	E	F	G
RIVER 150 F <b>a</b> M	2" 1/2	100	121	280,5	196	490	214
RIVER 150 F <b>a</b> T	2" 1/2	100	121	280,5	196	490	214
RIVER 200 F <b>a</b> M	2" 1/2	100	121	280,5	196	490	214
RIVER 200 F <b>a</b> T	2" 1/2	100	121	280,5	196	490	214
RIVER 300 F <b>c</b> T	3"	128	121	390	216	647	---
RIVER 400 F <b>c</b> T	3"	128	121	390	216	647	---
RIVER 600 F <b>c</b> T	3"	128	121	390	216	647	---

\*..c Monocanale chiusa / Close single channel

\*..a Monocanale aperta / Open single channel

MODELLO MODEL	DIMENSIONI SCATOLA / PACKING DIMENSIONS				DIMENSIONI PALLET / PALLET DIMENSIONS				
	L mm.	M mm.	N mm.	Peso / Weight Kg.	R mm.	S mm.	T mm.	nr. scatole/cartons	Peso / Weight Kg.
RIVER 150F M	260	300	530	23	800	1200	1750	36	850
RIVER 150F T	260	300	530	23	800	1200	1750	36	850
RIVER 200F M	260	300	530	28	800	1200	1750	36	1030
RIVER 200F T	260	300	530	28	800	1200	1750	36	1030
RIVER 300F T	720	400	260	53	800	1200	900	9	500
RIVER 400F T	720	400	260	54	800	1200	900	9	510
RIVER 600F T	720	400	260	55	800	1200	900	9	515

# TENAX



## **ELETTROPOMPE SOMMERSIBILI MONOCANALI PER ACQUE CARICHE DOTATE DI CONTROFLANGIA SUBMERSIBLE SINGLE CHANNEL ELECTRIC PUMP FOR VERY FOUL WASTE WATER, FEATURING A COUNTER FLANGE**

**PREVALENZA** ..... : 10,5 mt. ÷ 30,5 mt.  
**PORTATA** ..... : 30 m<sup>3</sup>/h ÷ 96 m<sup>3</sup>/h  
**POTENZA NOMINALE** : 1,1 kW (1,5HP) ÷ 4,5 kW (6HP)  
**PASSAGGIO SOLIDI FINO A 60 mm.**

**PUMP HEAD** ..... : 10,5 mt ÷ 30,5 mt  
**DELIVERY** ..... : 30,0 m<sup>3</sup>/h ÷ 96,0 m<sup>3</sup>/h  
**RATED HORSEPOWER** : 1,1 kW (1,5HP) ÷ 4,5 kW (6,0HP)  
**SOLID MATTER BYPASS up to 60 mm**

### **APPLICAZIONI**

- SVUOTAMENTO DI FOSSE DI DECANTAZIONE, POZZI DI RACCOLTA LIQUAMI.
- POMPAGGIO DI ACQUE LURIDE ANCHE CON CORPI SOLIDI E PARTI FIBROSE IN SOSPENSIONE.
- MOVIMENTAZIONE DI ACQUE LURIDE AD USO DOMESTICO E INDUSTRIALE.

### **APPLICATIONS**

- DECANTATION PIT, SLURRY COLLECTION PIT PUMP OUT.
- LAVATORY/FOUL WATER WITH FLOATING/NON-FLOATING SOLIDS AND FIBRE SUSPENSIDS PUMP OUT.
- DOMESTIC AND INDUSTRIAL LAVATORY/BLACK WATER HANDLING SYSTEMS.

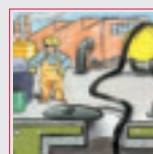
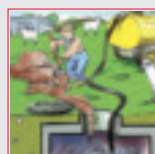
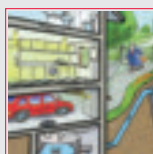

**AV ARVEN**

**CARATTERISTICHE DI COSTRUZIONE**

- ELETTOPOMPA A DOPPIA CAMERA (MOTORE, TENUTA MECCANICA).
- ELETTOPOMPA A UNICA CAMERA (SOLO PER TENAX 400F - 600F)
- MOTORE A BAGNO D'OLIO (BIODEGRADABILE E DIELETTRICO) PER RAFFREDDAMENTO E LUBRIFICAZIONE CUSCINETTI.
- ANELLO DI TENUTA LATO MOTORE.
- TENUTA MECCANICA A BAGNO D'OLIO.
- DOPPIA TENUTA MECCANICA (SOLO PER TENAX 400F - 600F):  
LATO MOTORE A BAGNO D'OLIO  
LATO POMPA A BAGNO D'ACQUA
- IMMERSIONE MASSIMA: mt. 5.
- GRADO DI PROTEZIONE IP 68.
- CLASSE DI ISOLAMENTO: F
- TEMPERATURA MAX. LIQUIDO POMPATO:  
25°C con pompa PARZIALMENTE immersa.  
35°C con pompa TOTALMENTE immersa.
- PASSAGGIO LIBERO: 50 mm - TENAX 150 F **a**  
60 mm - TENAX 200F **a**  
50 mm - TENAX 300F **c**  
50 mm - TENAX 400F **c**  
50 mm - TENAX 600F **c**
- VERSIONI: Monofase: 220-277V/50Hz o 220-277V/60 Hz con protettore termico incorporato e condensatore permanentemente inserito.  
Trifase: 220-277V/50Hz o 380-480V/50Hz e 220-277V/60Hz o 380-480V/60Hz con protezione da sovraccarico a cura dell'utente.
- POTENZA MOTORE: DA 1,5 Hp a 2 Hp VERSIONI MONOFASE E TRIFASE.  
DA 3 Hp a 6 Hp solo VERSIONI TRIFASE.
- VERSIONI MONOFASI AUTOMATICHE CON GALLEGGIANTE fino a 1,5 HP.  
VERSIONI MONOFASI da 2 Hp solo MANUALI SENZA GALLEGGIANTE.
- CAVO STANDARD:  
Monofase: 10 metri H07RN-F per versione normale (aut.-man).  
Trifase: 10 metri H07RN-F

SPECIALI VOLTAGGI E FREQUENZE A RICHIESTA.

**OPTIONAL:**

- SISTEMI DI DISCESA DN80 PER IMPIANTI FISSI (VEDERE PAGINA 100-101)

**DESIGN ENGINEERING**

- DOUBLE CHAMBER ELECTRIC PUMP (MOTOR, MECHANICAL SEAL).
  - SINGLE CHAMBER ELECTRIC PUMP (ONLY FOR TENAX 400F - 600F)
  - OIL BATH MOTOR (BIODEGRADABLE AND DIELECTRIC) FOR COOLING AND BEARING LUBRICATION.
  - SEALING RING - ENGINE FACE.
  - OIL BATH MECHANICAL SEALS.
  - DOUBLE MECHANICAL SEALS (ONLY FOR TENAX 300F):  
ENGINE FACE: OIL BATH  
PUMP FACE: WATER BATH
  - PERMISSIBLE DRAUGHT OF WATER: 5 m
  - IP 68 PROTECTION CLASS.
  - CLASS "F" INSULATION.
  - MAX. PUMPED LIQUID TEMPERATURE:  
25°C with PARTIALLY submerged pump.  
35°C with TOTALLY submerged pump.
  - BY PASS SECTION: 50 mm - TENAX 150 F **a**  
60 mm - TENAX 200F **a**  
50 mm - TENAX 300F **c**  
50 mm - TENAX 400F **c**  
50 mm - TENAX 600F **c**
  - VERSIONS: Single Phase: 220-277V/50Hz or 220-277V/60Hz with built in thermal protection and permanent capacitor.  
Three Phase: 220-277V/50Hz or 380-480V/50Hz and 220-277V/60Hz or 380-480V/60Hz with overload protection care of the User.
  - MOTOR POWER: From 1,5 HP to 2 HP single phase and three phase versions.  
3 HP Only three phase versions.
  - AUTOMATIC SINGLE PHASE VERSIONS up to 1,1 kW (1,5 HP).  
SINGLE PHASE VERSIONS from 1.5 kW (2 HP) only manual, without floater.
  - STANDARD CABLE FEATURES:  
Single Phase: 10 metres H07RN-F for the standard version (automatic-manual).  
Three Phase: 10 metres H07RN-F
- CUSTOMISED VOLTAGE AND FREQUENCY RATING AVAILABLE ON DEMAND.

**OPTIONAL:**

- DOWN STROKE GUIDE RAIL SYSTEMS DN80 FOR FIXED PLANTS (SEE PAGE 100-101)

**TABELLA MATERIALI / MATERIALS TABLE:**

Pos.	Componente / Component		Materiale / Materials
A	Carcassa esterna / External housing		ACCIAIO INOX AISI 304 - DIN 1.4301 STAINLESS STEEL
B	TENAX 150F-200F	Girante / Impeller	ACCIAIO INOX AISI 316 - DIN 1.4401 STAINLESS STEEL
	TENAX 300F-600F		
C	Albero (lato pompa) / Shaft (pump side)		CARBURO DI SILICIO-CERAMICA SILICON CARBIDE - CERAMIC
D	Tenuta meccanica Mechanical seal	Lato pompa / Pump face	
		Lato motore Motor face	
E	O-Ring		NBR
G	Porta motore / Motor holder	TENAX 150F-200F	ACCIAIO INOX AISI 304 - DIN 1.4301 STAINLESS STEEL
H	Cassa motore / Motor housing		
I	Coperchio + maniglia / Cover + Handle		
N	Base d'appoggio / Grid holder		
P	Corpo pompa / Pump body		
R	Flangia portamotore inferiore / Lower motor-flange		GHISA (G20) CAST IRON
S	Flangia portamotore superiore / Upper motor flange		
T	Controflangia aspirazione / Suction counter-flange		ACCIAIO INOX AISI 304 - DIN 1.4301 STAINLESS STEEL

TENAX 150F - 200F

TENAX 300F - 400F - 600F

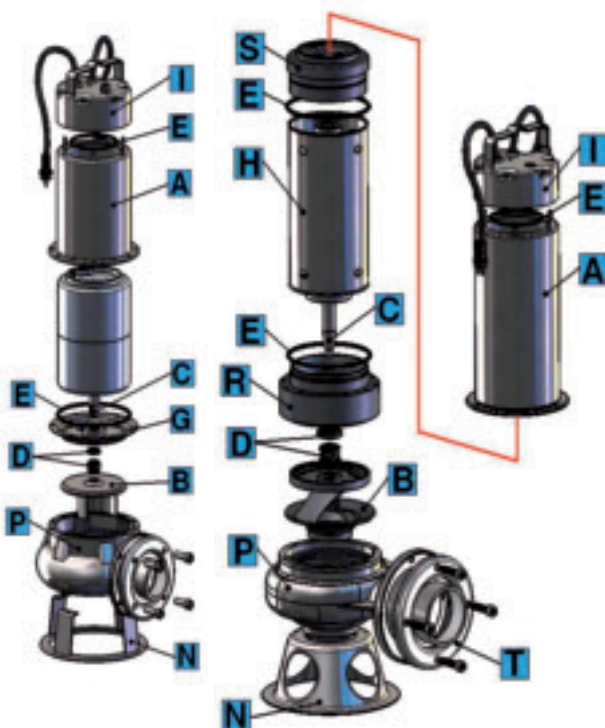

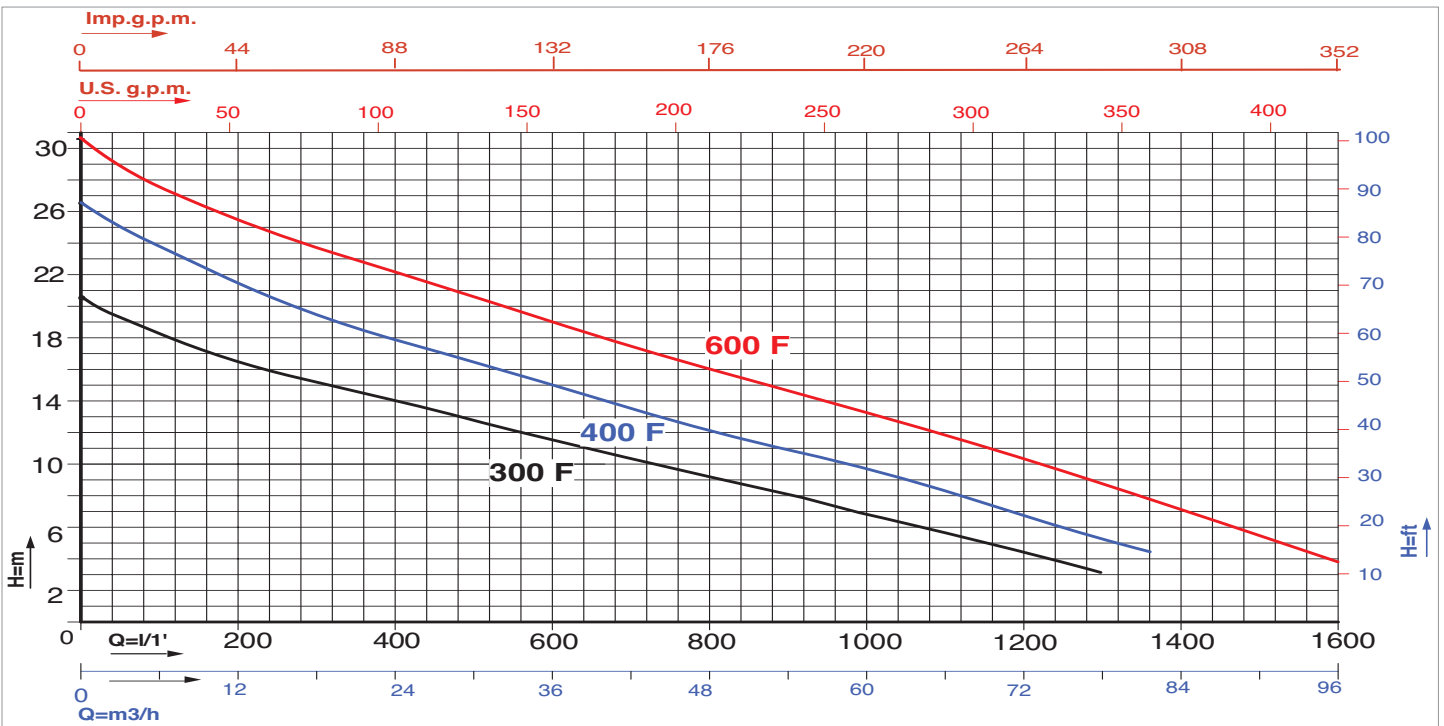
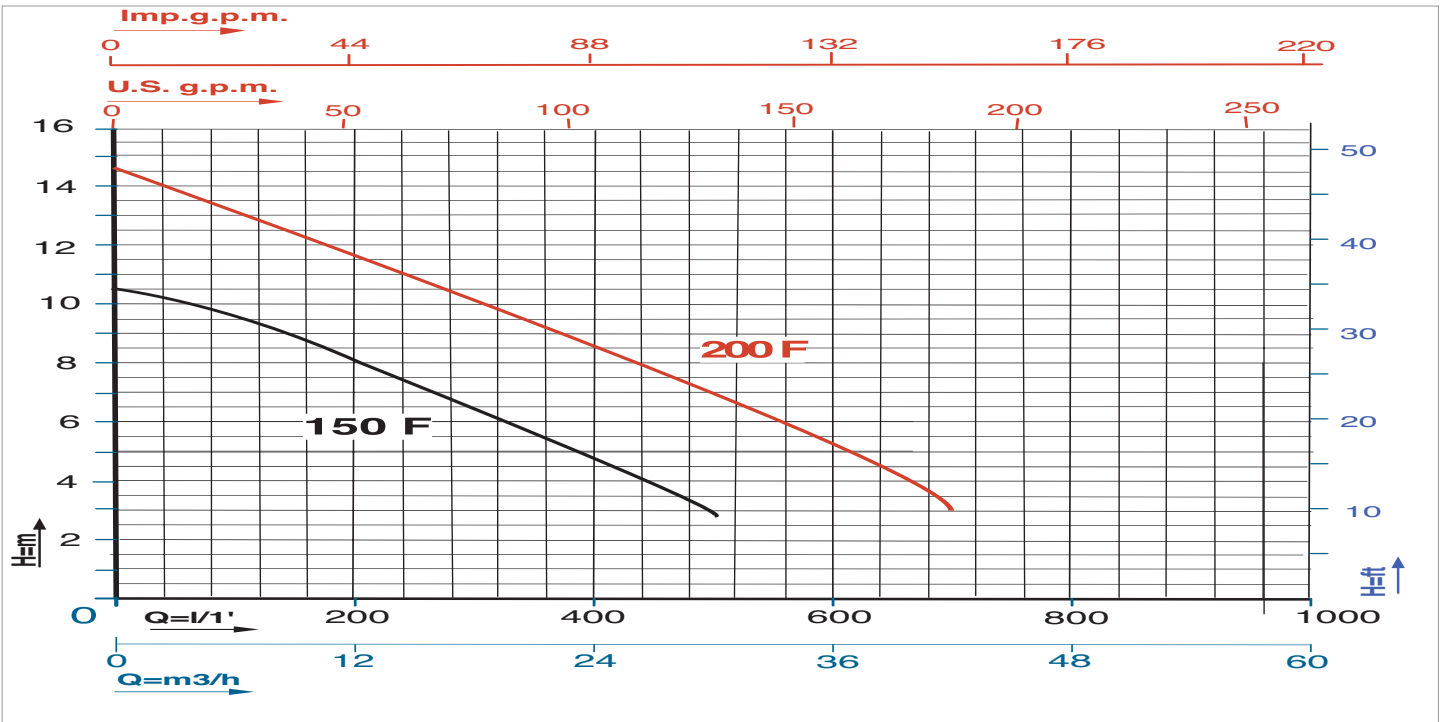

Caratteristiche di funzionamento a 2800 rpm 50Hz e 3450 rpm 60Hz - Performances at 2800 rpm 50 Hz and 3450 rpm 60 Hz  
 Le prestazioni valgono per liquidi con densità  $\rho = 1,0 \text{ kg/dm}^3$  ed una viscosità  $\nu = 1 \text{ mm}^2/\text{s}$  / The performance data holds true for liquids with a  $\rho = 1,0 \text{ kg/dm}^3$  density and a  $\nu = 1 \text{ mm}^2/\text{s}$  viscosity.

Modello MODEL	VOLTAGGIO VOLTAGE 50Hz	DATI ELETTRICI / ELECTRICAL DATA						DATI IDRAULICI / HYDRAULIC DATA									
		P1max		P2 nom.		I max	Condensatore Capacitor	PREVALENZA TOTALE IN METRI COLONNA ACQUA / TOTAL PUMP HEAD AND WATER COLUMN HEIGHT IN m.									
		kW	kW	HP	Ampere	$\mu\text{F}$		VC	m³/h	0	3	15	30	39	57	72	81
TENAX 150F a M	1 x 220-240V	2,1	1,1	1,5	9,0	40	450	l/min.	0	50	250	500	650	950	1200	1350	1600
TENAX 150F a T	3 x 380 - 400V	1,8	1,1	1,5	3,2	---	---	H (m)	10,5	9,7	6,6	2,8					
TENAX 200F a M	1 x 220-240V	2,9	1,5	2,0	13	40	450		10,5	9,7	6,6	2,8					
TENAX 200F a T	3 x 380 - 400V	2,6	1,5	2,0	4,6	---	---		14,5	13,7	10,2	5,7	3,0				
TENAX 300F c T	3 x 380 - 400V	3,4	2,25	3,0	6,9	---	---		14,5	13,7	10,2	5,7	3,0				
TENAX 400F c T	3 x 380 - 400V	4,0	3,0	4,0	8,1	---	---		20,5	18,6	15,2	12,2	10,5	6,9	3,8		
TENAX 600F c T	3 x 380 - 400V	5,5	4,5	6,0	9,5	---	---		26,5	25,0	20,5	16,5	14,3	10,4	6,0	4,6	
									30,5	28,7	24,4	20,4	18,0	13,8	9,4	7,8	3,7



**DIMENSIONI e PESI / SIZE AND WEIGHT DATA:**

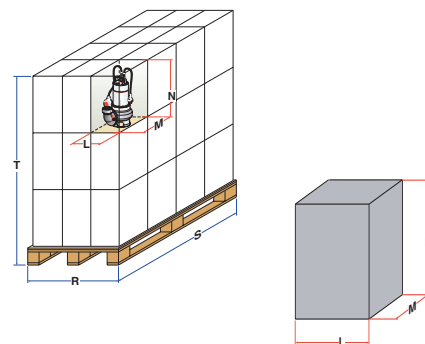
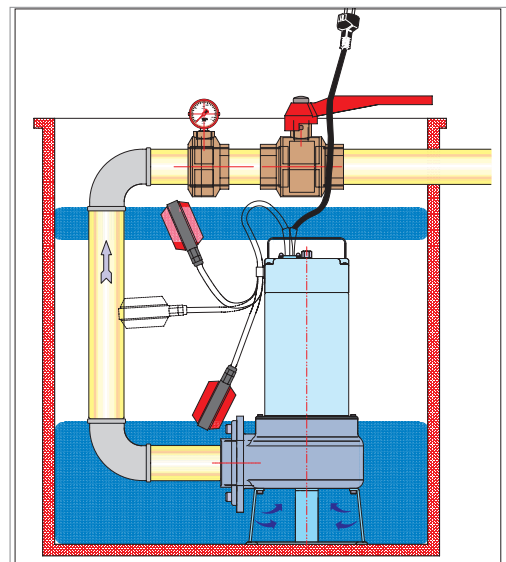
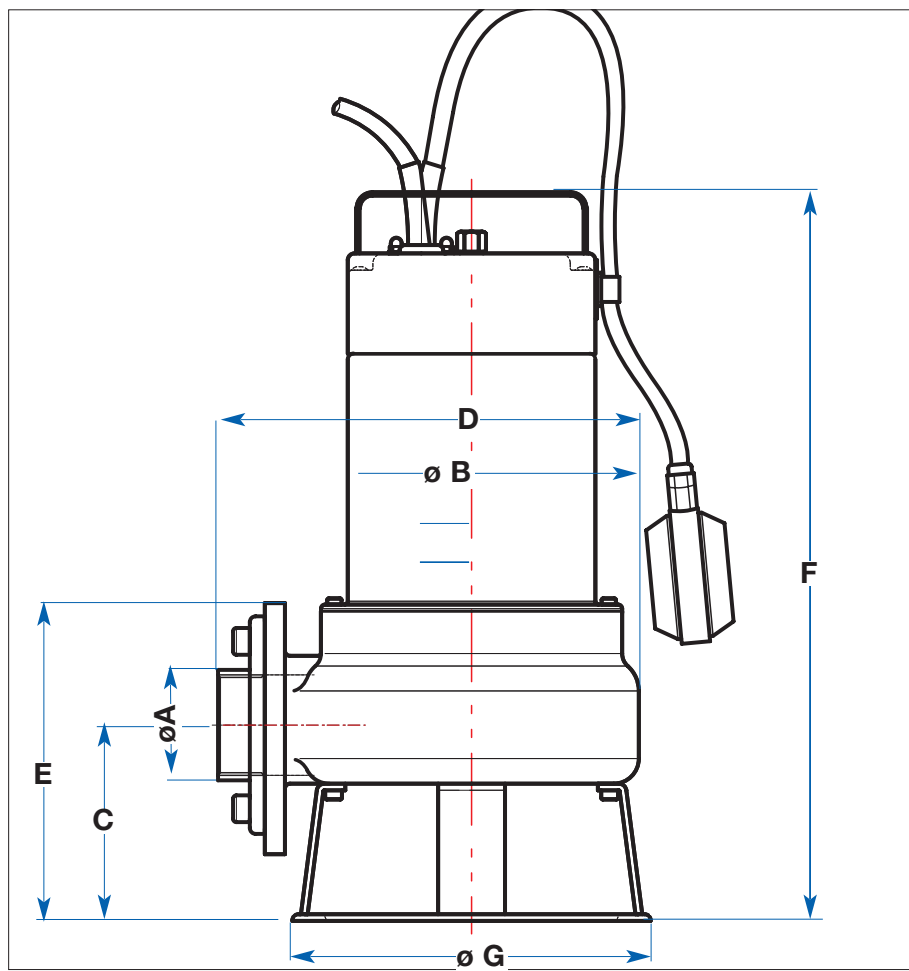

MODELLO MODEL	DIMENSIONI POMPA in mm. / PUMP DIMENSIONS in mm.						
	A	B	C	D	E	F	G
TENAX 150F <b>a</b> M	2" 1/2	115	116,5	260	192	473	214
TENAX 150F <b>a</b> T	2" 1/2	115	116,5	260	192	473	214
TENAX 200F <b>a</b> M	2" 1/2	115	116,5	260	192	473	214
TENAX 200F <b>a</b> T	2" 1/2	115	116,5	260	192	473	214
TENAX 300F <b>c</b> T	3"	119	190	390	285	662	279
TENAX 400F <b>c</b> T	3"	119	190	390	285	662	279
TENAX 600F <b>c</b> T	3"	119	190	390	285	662	279

\* **..c** Monocanale chiusa / Close single channel

\* **..a** Monocanale aperta / Open single channel

MODELLO MODEL	DIMENSIONI SCATOLA / PACKING DIMENSIONS				DIMENSIONI PALLET / PALLET DIMENSIONS				
	L mm.	M mm.	N mm.	Peso / Weight Kg.	R mm.	S mm.	T mm.	nr. scatole/cartons	Peso / Weight Kg.
TENAX 150F <b>a</b> M	260	300	530	19	800	1200	1750	36	709
TENAX 150F <b>a</b> T	260	300	530	19	800	1200	1750	36	709
TENAX 200F <b>a</b> M	260	300	530	22,5	800	1200	1750	36	835
TENAX 200F <b>a</b> T	260	300	530	22,5	800	1200	1750	36	835
TENAX 300F <b>c</b> T	720	400	260	28	800	1200	900	9	280
TENAX 400F <b>c</b> T	720	400	260	33	800	1200	900	9	325
TENAX 600F <b>c</b> T	720	400	260	37	800	1200	900	9	360

# CUTTER



## **ELETTROPOMPE SOMMERSIBILI TRITURATRICI PER ACQUE SPORCHE E CARICHE SUBMERSIBLE ELECTRIC GRINDER PUMPS FOR FOUL AND HEAVY WASTE WATER**

**PREVALENZA** ..... : 16,5 mt. ÷ 23,5 mt.  
**PORTATA** ..... : 9 m<sup>3</sup>/h ÷ 21 m<sup>3</sup>/h  
**POTENZA NOMINALE** : 1,1 kW (1,5HP) ÷ 2,25 kW (3HP)

**PUMP HEAD** ..... : 16,5 mt ÷ 23,5 mt  
**DELIVERY** ..... : 9,0 m<sup>3</sup>/h ÷ 21,0 m<sup>3</sup>/h  
**RATED HORSEPOWER** : 1,1 kW (1,5HP) ÷ 2,25 kW (3,0HP)

### **APPLICAZIONI**

- POMPAGGIO E TRITURAZIONE DI ACQUE LURIDE CON CORPI SOLIDI E PARTI FIBROSE
- SVUOTAMENTO DI FOSSE DI DECANTAZIONE POZZI NERI POZZI DI RACCOLTA LIQUAMI
- MOVIMENTAZIONE DI ACQUE LURIDE AD USO DOMESTICO E INDUSTRIALE

### **APPLICATIONS**

- GRINDING AND PUMP OUT OF LAVATORY/FOUL WATER WITH FLOATING SOLIDS AND FIBRE SUSPENSIDS .
- DECANTATION PIT, SEWAGE PIT AND SLURRY COLLECTION PIT PUMP OUT
- DOMESTIC AND INDUSTRIAL LAVATORY/BLACK WATER HANDLING SYSTEMS.

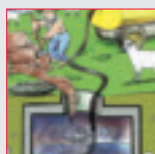
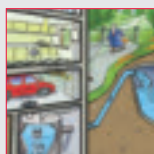

**AV ARVEN**

**CARATTERISTICHE DI COSTRUZIONE**

- ELETTRICITÀ A DOPPIA CAMERA (MOTORE, TENUTA MECCANICA).
- MOTORE A BAGNO D'OLIO (BIODEGRADABILE E DIELETTRICO) PER RAFFREDDAMENTO E LUBRIFICAZIONE CUSCINETTI.
- ANELLO DI TENUTA LATO MOTORE.
- DOPPIA TENUTA MECCANICA: LATO MOTORE A BAGNO D'OLIO. (ESCLUSA CUTTER 140)

LATO POMPA A BAGNO D'ACQUA.

- IMMERSIONE MASSIMA: mt. 5.
- GRADO DI PROTEZIONE IP 68.
- CLASSE DI ISOLAMENTO: F
- TEMPERATURA MAX. LIQUIDO POMPATO: 25°C PARZIALMENTE immersa  
35°C TOTALMENTE immersa

- VERSIONI: Monofase: 220-277V/50Hz o 220-277V/60Hz con protettore termico incorporato e condensatore permanentemente inserito. (CUTTER 140)  
Trifase: 220-277V/50Hz o 380-480V/50Hz e 220-277V/60Hz o 380-480V/60Hz con protezione da sovraccarico a cura dell'utente.

- POTENZA MOTORE: DA 1,5 Hp a 2 Hp VERSIONI MONOFASE E TRIFASE.  
DA 3 Hp solo VERSIONI TRIFASE.

- VERSIONI MONOFASI AUTOMATICHE SOLO FINO A 1,5 HP.

- CAVO STANDARD:  
Monofase: 10 metri H07RN-F completa di quadro elettrico con spezzone 0,7metri senza spina.  
Trifase: 10 metri H07RN-F.

SPECIALI VOLTAGGI E FREQUENZE A RICHIESTA.

**OPTIONAL:**

- SISTEMI DI DISCESA DN50 PER IMPIANTI FISSI (VEDERE PAGINA 100)

**DESIGN ENGINEERING**

- DOUBLE CHAMBER ELECTRIC PUMP (MOTOR, MECHANICAL SEAL).
- OIL BATH MOTOR (BIODEGRADABLE AND DIELECTRIC) FOR COOLING AND BEARING LUBRICATION.
- SEALING RING - ENGINE FACE.
- DOUBLE MECHANICAL SEALS: ENGINE FACE: OIL BATH. (ESCLUDED CUTTER 140)

PUMP FACE: WATER BATH.

- PERMISSIBLE DRAUGHT OF WATER: 5 m
- IP 68 PROTECTION CLASS.
- CLASS "F" INSULATION.
- MAX. PUMPED LIQUID TEMPERATURE:  
25°C with PARTIALLY submerged pump.  
35°C with TOTALLY submerged pump.

- VERSIONS: Single Phase: 220-277V/50Hz or 220-277V/60Hz with built in thermal protection and permanent capacitor. (CUTTER 140)  
Three Phase: 22-277V/50Hz or 380-480V/50Hz and 220-277V/60Hz or 380-480V/60Hz with overload protection care of the User.

- MOTOR POWER: From 1,5 HP to 2 HP single phase and three phase versions.  
From 3 HP only three phase versions.

- AUTOMATIC SINGLE PHASE VERSIONS ONLY UP TO 1.5 HP.

- STANDARD CABLE FEATURES:  
Single Phase: 10 metres H07RN-F complete with power supply box 0,7m cable section, without connection plug.  
Three Phase: 10 metres H07RN-F.

CUSTOMISED VOLTAGE AND FREQUENCY RATING AVAILABLE ON DEMAND.

**OPTIONAL:**

- DOWN STROKE GUIDE RAIL SYSTEMS DN50 FOR FIXED PLANTS (SEE PAGE 100)

**TABELLA MATERIALI / MATERIALS TABLE:**

Pos.	Componente / Component		Materiale / Materials
A	Carcassa esterna / External housing		ACCIAIO INOX AISI 304 - DIN 1.4301 STAINLESS STEEL
B	Girante / Impeller		GHISA G20 / CAST IRON
C	Albero (lato pompa) / Shaft (pump side)		ACCIAIO INOX AISI 316 - DIN 1.4401 STAINLESS STEEL
D	Tenuta meccanica Mechanical seal	Lato pompa / Pump face	CARBURO DI SILICIO-CERAMICA SILICON CARBIDE-CERAMIC
		Lato motore Motor face	CUTTER 140 ANELLO DI TENUTA NBR NBR SEAL RING CUTTER 150-200-300 GRAFITE - CERAMICA GRAPHITE - CERAMIC
E	O-Ring		NBR
I	Coperchio + maniglia / Cover + handle		ACCIAIO INOX AISI 304 - DIN 1.4301 STAINLESS STEEL
L	Diffusore / Pump body		GHISA (G20) CAST IRON
P	Corpo pompa / Pump body		
N	Base d'appoggio / Grid holder		ACCIAIO INOX AISI 304 - DIN 1.4301 STAINLESS STEEL
Z	Sistema trituratore / Grinder system		ACCIAIO INOX AISI 440C - DIN 1.4125 STAINLESS STEEL

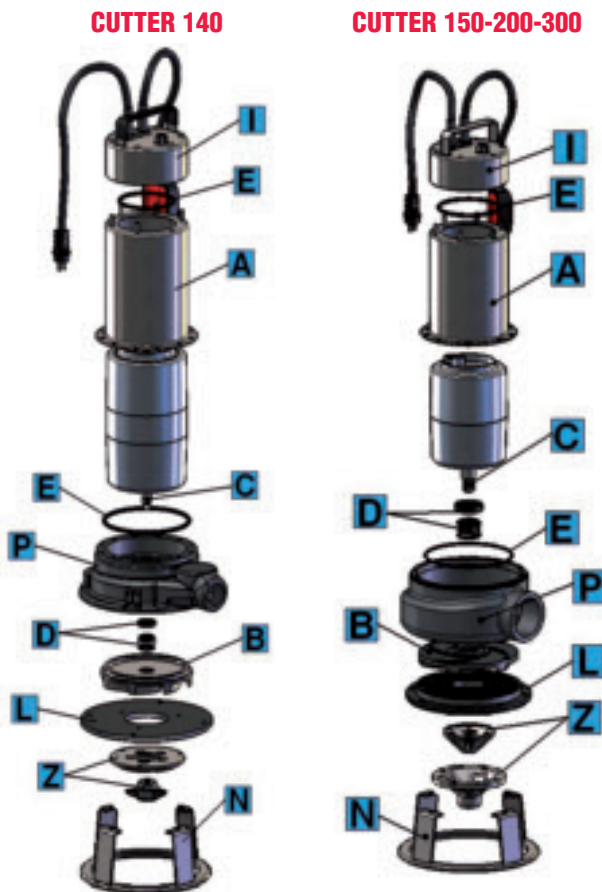

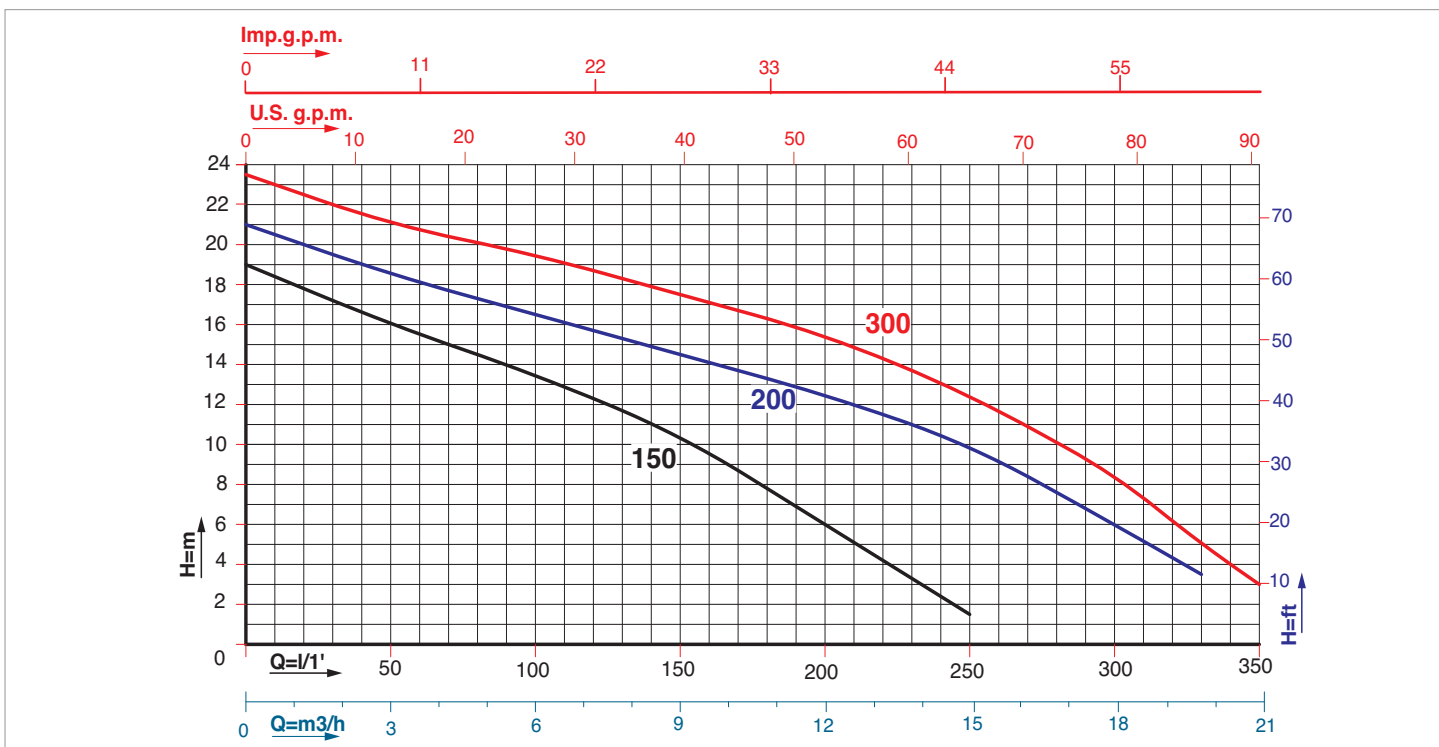
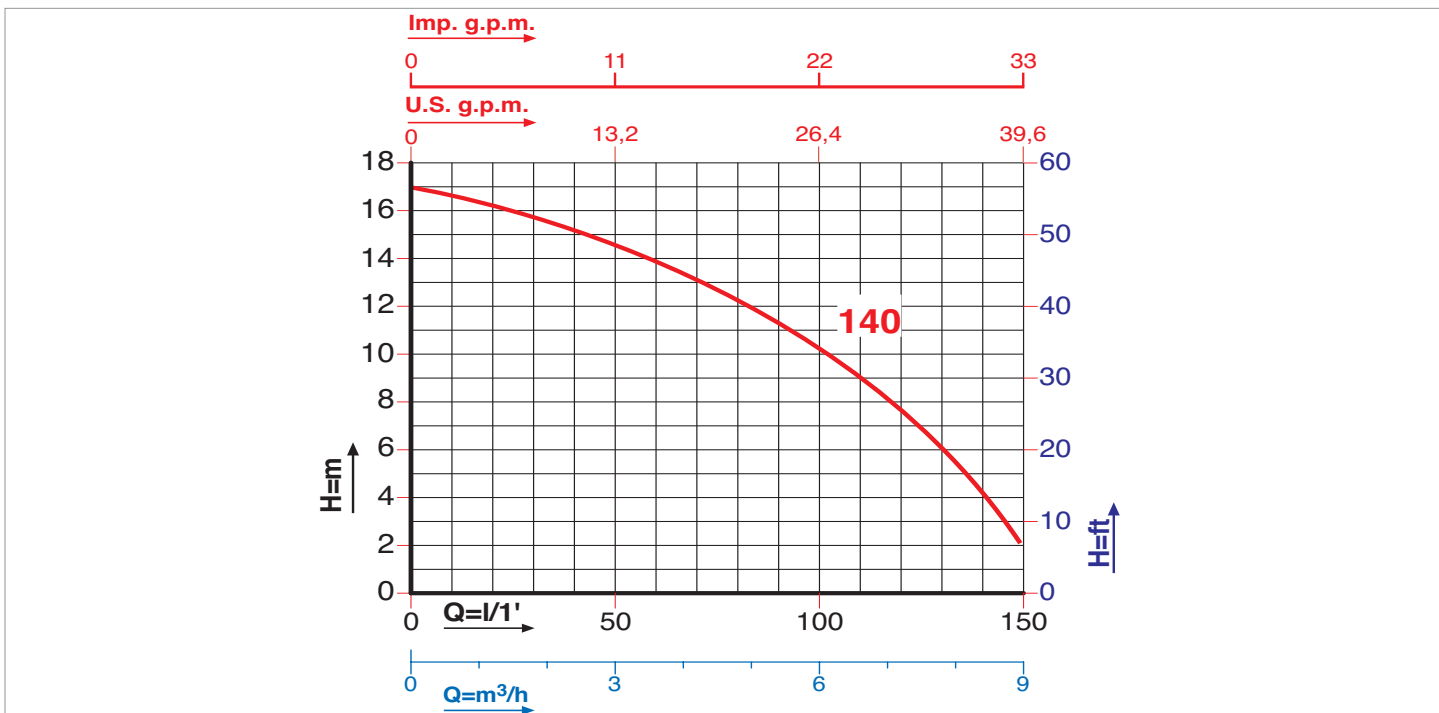

Caratteristiche di funzionamento a 2800 rpm 50Hz e 3450 rpm 60Hz - Performances at 2800 rpm 50 Hz and 3450 rpm 60 Hz  
 Le prestazioni valgono per liquidi con densità  $\rho = 1,0 \text{ kg/dm}^3$  ed una viscosità  $\nu = 1 \text{ mm}^2/\text{s}$  / The performance data holds true for liquids with a  $\rho = 1,0 \text{ kg/dm}^3$  density and a  $\nu = 1 \text{ mm}^2/\text{s}$  viscosity.

MODELLO MODEL	VOLTAGGIO VOLTAGE 50 Hz	DATI ELETTRICI / ELECTRICAL DATA					DATI IDRAULICI / HYDRAULIC DATA										
		P1 max kW	P2 nom. kW	I max HP	I max Ampere	Condensatore Capacitor $\mu\text{F}$	VC	m³/h	0	3	6	9	12	15	18	19,8	21
							l/min.	0	50	100	150	200	250	300	330	350	
CUTTER 140 M	1 x 220-230V	1,6	1,1	1,5	7,1	30	450	H (m)	17,0	14,5	10,0	2,0					
CUTTER 140 T	3 x 380-400V	1,3	1,1	1,5	3,0	---	---		17,0	14,5	10,0	2,0					
CUTTER 150 M	1 x 220-230V	2,2	1,1	1,5	10,5	80	450	PRESSIONE TOTALE IN METRI COLONNINA ACQUA / TOTAL PUMP HEAD AND WATER COLUMN HEIGHT IN m.	19,0	16,0	13,5	10,5	6,0	1,5			
CUTTER 150 T	3 x 380-400V	2,0	1,1	1,5	4,0	---	---		19,0	16,0	13,5	10,5	6,0	1,5			
CUTTER 200 M	1 x 220-230V	2,9	1,5	2,0	13,0	80	450	21,0	18,5	16,5	14,5	12,5	10,0	6,0	3,5		
CUTTER 200 T	3 x 380-400V	2,5	1,5	2,0	4,5	---	---	21,0	18,5	16,5	14,5	12,5	10,0	6,0	3,5		
CUTTER 300 T	3 x 380-400V	3,4	2,25	3,0	6,0	---	---	23,5	21,0	19,5	17,5	15,5	12,5	8,5	5,0	3,0	

**DIMENSIONI e PESI / SIZE AND WEIGHT DATA:**

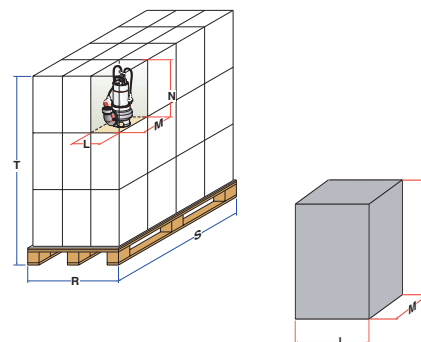
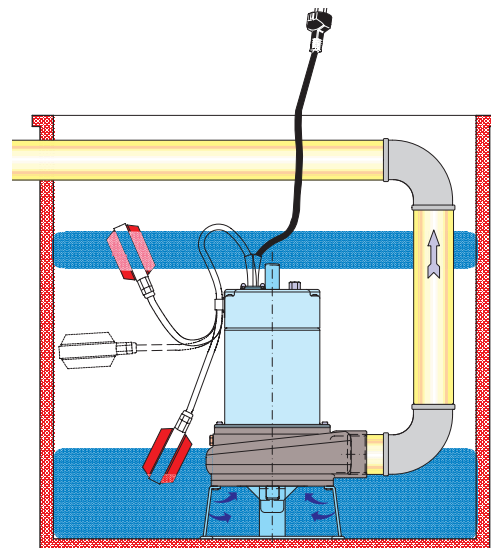
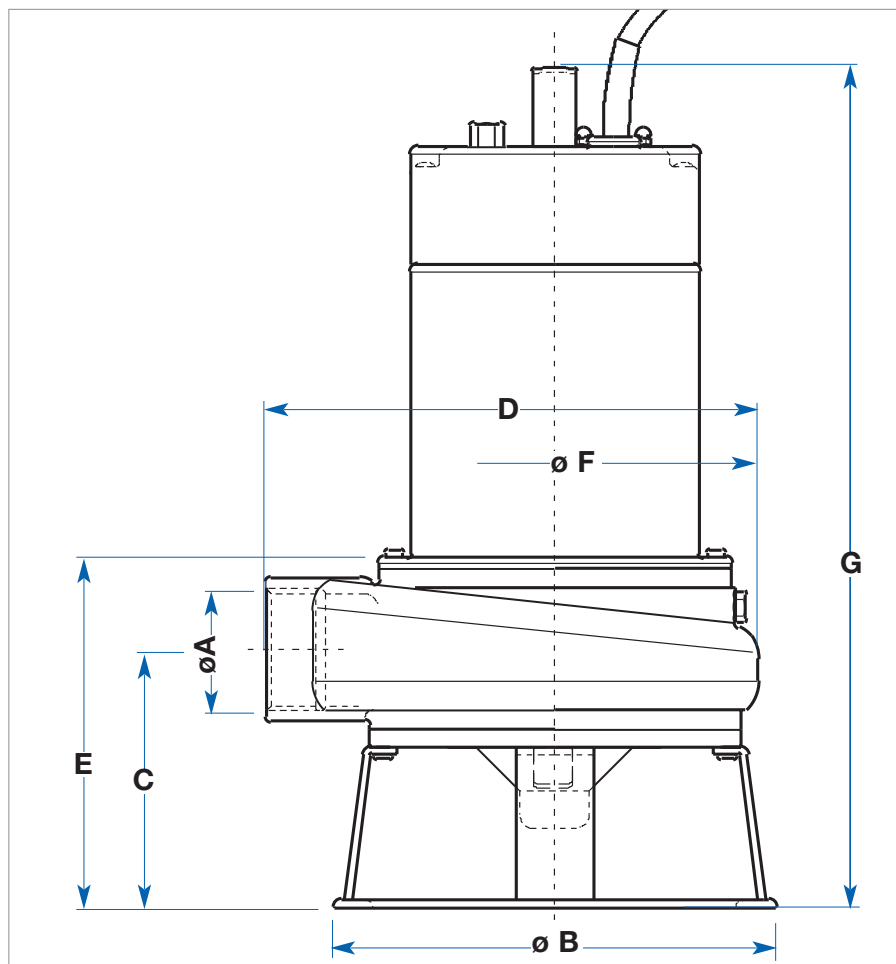

MODELLO / MODEL	DIMENSIONI POMPA in mm. / PUMP DIMENSIONS in mm.						
	A	B	C	D	E	F	G
CUTTER 140 M	1" 1/2	225	102,5	213,5	126	156	356
CUTTER 140 T	1"1/2	225	102,5	213,5	126	156	356
CUTTER 150 M	2"	225	131,5	260	165	215	425
CUTTER 150 T	2"	225	131,5	260	165	215	425
CUTTER 200 M	2"	225	131,5	260	165	215	425
CUTTER 200 T	2"	225	131,5	260	165	215	425
CUTTER 300 T	2"	225	131,5	260	165	215	425

MODELLO / MODEL	DIMENSIONI SCATOLA / PACKING DIMENSIONS				DIMENSIONI PALLET / PALLET DIMENSIONS				
	L mm.	M mm.	N mm.	Peso / Weight Kg.	R mm.	S mm.	T mm.	nr. scatole/cartons	Peso / Weight Kg.
CUTTER 140 M	260	320	340	21	800	1200	1400	36	771
CUTTER 140 T	260	320	340	21	800	1200	1400	36	771
CUTTER 150 M	260	300	530	25,5	800	1200	1750	36	933
CUTTER 150 T	260	300	530	25,5	800	1200	1750	36	933
CUTTER 200 M	260	300	530	28,5	800	1200	1750	36	1050
CUTTER 200 T	260	300	530	28,5	800	1200	1750	36	1050
CUTTER 300 T	260	300	530	29	800	1200	1750	36	1070



# ROXY



## **ELETTROPOMPE SOMMERSIBILI MULTISTADIO VERTICAL SUBMERSIBLE SINGLE-BLOCK MULTISTAGE**

**PREVALENZA** ..... : **38,0 mt.**  
**PORTATA** ..... : **4,5 m<sup>3</sup>/h**  
**POTENZA NOMINALE** : **0,55 kW** (0,75HP)

**PUMP HEAD** ..... : **38,0 mt**  
**DELIVERY** ..... : **4,5 m<sup>3</sup>/h**  
**RATED HORSEPOWER** : **0,55 kW** (0,75HP)

### **APPLICAZIONI**

- SVUOTAMENTO DA ACQUE PIOVANE, D'INFILTRAZIONE, DI POZZETTI O VASCHE DI RACCOLTA.
- PRELIEVO DA VASCHE DI RACCOLTA DI ACQUE PIOVANE PER PICCOLE IRRIGAZIONI A SCORRIMENTO DI ORTI E DI GIARDINI.
- TRAVASO DI ACQUA CHIARA DA SERBATOI E VASCHE.

### **APPLICATIONS**

- RAIN, SEEPAGE, SUMP PIT AND CATCH TANK WATER PUMP OUT.
- GARDEN AND VEGETABLE-GARDEN MINI FLOOD IRRIGATION SYSTEM RAINWATER CATCH TANK PUMP DOWN.
- WHITE WATER PUMP OVER FROM RESERVOIRS AND VATS.

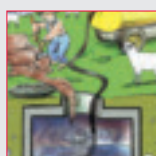
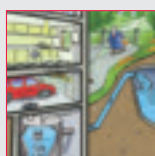

**AV ARVEN**

**CARATTERISTICHE DI COSTRUZIONE:**

- MOTORE A SECCO RAFFREDDATO DAL LIQUIDO POMPATO
- DOPPIA TENUTA MECCANICA: DOPPIO ANELLO DI TENUTA LATO MOTORE, TENUTA MECCANICA A BAGNO D'OLIO LATO POMPA
- IMMERSIONE MASSIMA: mt. 10.
- GRADO DI PROTEZIONE IP 68.
- CLASSE DI ISOLAMENTO: F
- TEMPERATURA MAX.LIQUIDO POMPATO: 35°C
- VERSIONI: Monofase: 220-277V/50Hz o 220-277V/60Hz con protettore termico incorporato e condensatore permanentemente inserito.
- CAVO STANDARD:  
Monofase: 10 metri H07RN-F per versione normale (aut.-man).

SPECIALI VOLTAGGI E FREQUENZE A RICHIESTA.

**DESIGN ENGINEERING:**

- SEMI WET MOTOR WATERCOOLED
- DOUBLE MECHANICAL SEAL: DOUBLE SEAL RING -ENGINE FACE OIL BATH MECHANICAL SEALS PUMP FACE
- PERMISSIBLE DRAUGHT OF WATER: 10 m
- IP 68 PROTECTION CLASS.
- CLASS "F" INSULATION.
- MAX. PUMPED LIQUID TEMPERATURE: 35°C
- VERSIONS: Single Phase: 220-277V/50Hz or 220-277V/60Hz with built in thermal protection and permanent capacitor.
- STANDARD CABLE FEATURES:  
Single phase :10 metres H07RN-F for the standard version (automatic-manual).

CUSTOMISED VOLTAGE AND FREQUENCY RATING AVAILABLE ON DEMAND.

**TABELLA MATERIALI - MATERIALS TABLE:**

Pos.	Componente - Component	Materiale - Materials
A	Carcassa esterna / External motor housing	ACCIAIO INOX AISI 304 - DIN 1.4301 / STAINLESS STEEL
B	Girante / Impeller	TECNOPOLIMERO TECNOPOLYMER
C	Albero (lato pompa) / Shaft (pump side)	ACCIAIO INOX AISI 303 - DIN 1.4005 / STAINLESS STEEL
D	Tenuta meccanica Mechanical seal	Lato motore / Motor face DOPPIO ANELLO DI TENUTA NBR NBR DOUBLE SEALING RING
		Lato pompa / Pump face GRAFITE-CERAMICA GRAPHITE - CERAMIC
E	O-ring	NBR
F	Porta tenuta / Seal holder	ACCIAIO INOX AISI 304 - DIN 1.4301 / STAINLESS STEEL
G	Porta motore / Motor holder	TECNOPOLIMERO TECNOPOLYMER
H	Cassa motore / Motor housing	ACCIAIO INOX AISI 304 - DIN 1.4301 / STAINLESS STEEL
I	Coperchio / Cover	TECNOPOLIMERO TECNOPOLYMER
K	Distanziale / Spacer	NORYL
L	Diffusori / Diffusers	TECNOPOLIMERO TECNOPOLYMER
N	Base d'aspirazione / Suction base	ACCIAIO INOX AISI 304 - DIN 1.4301 STAINLESS STEEL
Y	Piatto diffusori / Diffusers plate	FERRO / STEEL

**ROXI 75**





Caratteristiche di funzionamento a 2800 rpm 50Hz e 3450 rpm 60Hz - Performances at 2800 rpm 50 Hz and 3450 rpm 60 Hz  
 Le prestazioni valgono per liquidi con densità  $\rho = 1,0 \text{ kg/dm}^3$  ed una viscosità  $\nu = 1 \text{ mm}^2/\text{s}$  / The performance data holds true for liquids with a  $\rho = 1,0 \text{ kg/dm}^3$  density and a  $\nu = 1 \text{ mm}^2/\text{s}$  viscosity.

MODELLO MODEL	VOLTAGGIO VOLTAGE	DATI ELETTRICI / ELECTRICAL DATA						DATI IDRAULICI / HYDRAULIC DATA						
		P1 max		P2 nom.		I max	Condensatore Capacitor		m³/h		l/min.		H (m)	
		kW	kW	HP	Ampere	µF	VC	0	1,0	2,0	3,0	4,0	4,5	
ROXI 75 M	1 x 220-230V	0,95	0,55	0,75	4,2	14,0	450	38,0	34,0	28,5	20,5	10,0	3,0	

PREVALENZA TOTALE in METRI COLONNA ACQUA  
 TOTAL PUMP HEAD AND WATER COLUMN HEIGHT IN m.

**DIMENSIONI E PESI / SIZE AND WEIGHT DATA :**

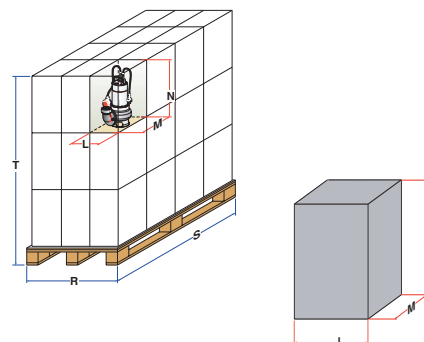
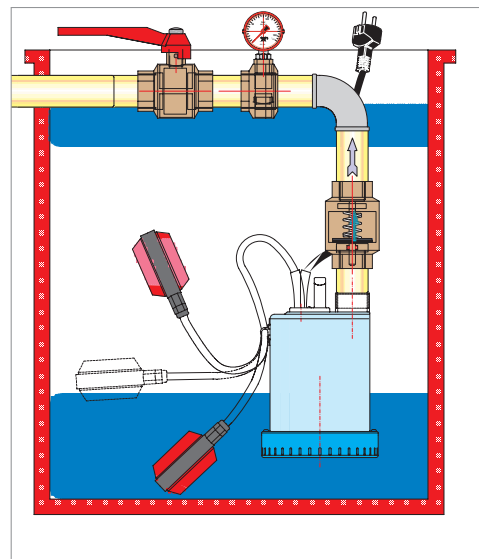
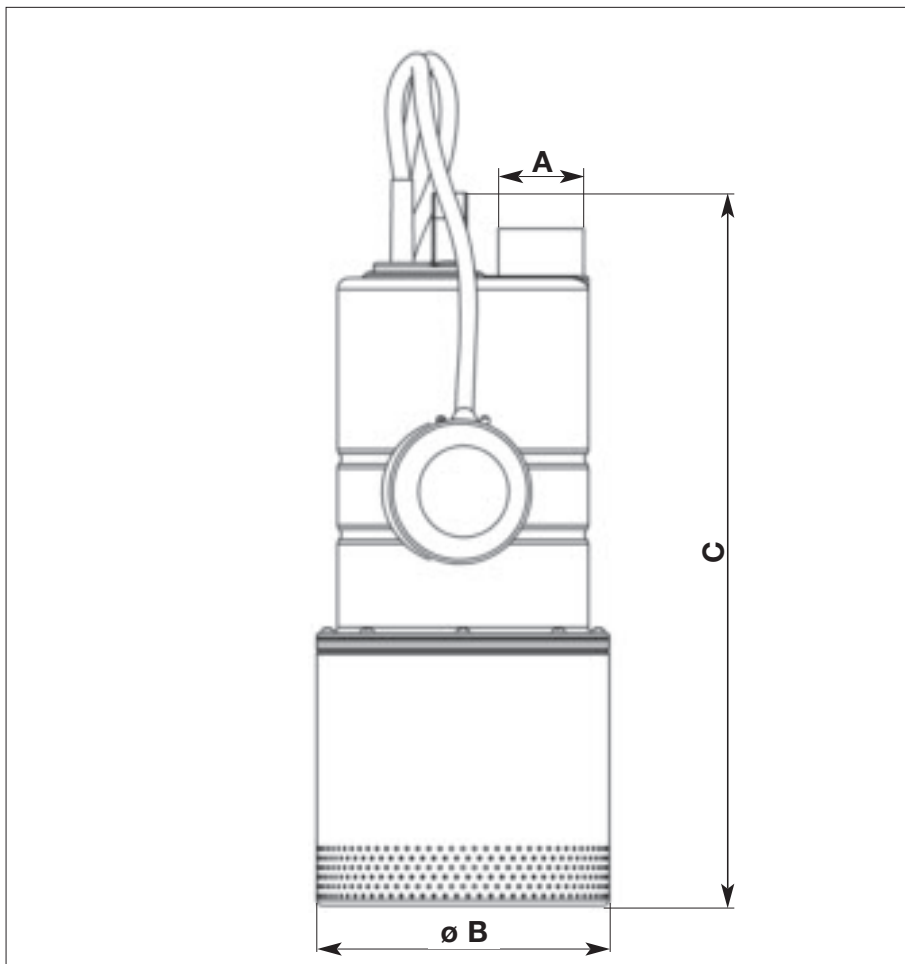

MODELLO MODEL	DIMENSIONI POMPA in mm. / PUMP DIMENSIONS in mm.		
	A	B	C
ROXI 75 M	1" 1/4	154	376,5

MODELLO MODEL	DIMENSIONI SCATOLA / PACKING DIMENSIONS				DIMENSIONI PALLET / PALLET DIMENSIONS				
	L mm	M mm	N mm	Peso / Weight Kg	R mm	S mm	T mm	nr. scatole/cartons	Peso / Weight Kg
ROXI 75 M	220	190	415	8,0	800	1200	1810	80	655

# GPV.RX



## **ELETTROPOMPE SOMMERSIBILI MONOBLOCCO MULTISTADIO VERTICALI, PER POZZI DA 6'' VERTICAL SUBMERSIBLE SINGLE BLOCK MULTI STAGE ELECTRIC PUMPS, FOR 6 INCH WELLS**

**PREVALENZA** ..... : 44 mt. ÷ 76,5 mt.  
**PORTATA** ..... : 4,5 m<sup>3</sup>/h  
**POTENZA NOMINALE** : 0,75 kW (1HP) ÷ 1,5 kW (2HP)

**PUMP HEAD** ..... : 44 mt ÷ 76,5 mt  
**DELIVERY** ..... : 4,5 m<sup>3</sup>/h  
**RATED HORSEPOWER** : 0,75 kW (1HP) ÷ 1,5 kW (2HP)

### **APPLICAZIONI**

- IMPIANTI PER LA MOVIMENTAZIONE DI ACQUE NEI SETTORI CIVILE ED INDUSTRIALE
- IMPIANTI DI PRESSURIZZAZIONE.
- IMPIANTI DI APPROVIGIONAMENTO IDRICO DA VASCHE DI PRIMA RACCOLTA, POZZI DA 6'', POZZI ROMANI, BACINI E CORSI D'ACQUA.
- IRRIGAZIONE A PIOGGIA.

### **APPLICATIONS**

- CIVIL AND INDUSTRIAL WATERS HANDLING PLANTS
- PRESSURISATION PLANTS.
- WATER SUPPLY FROM RAIN WATER TANKS OR RESERVOIRS, 6'' WELLS, ROMAN WELLS, BASINS AND WATERCOURSES.
- SPRINKLER SYSTEMS.

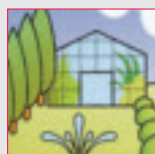
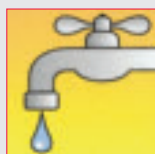

**AV ARVEN**



**CARATTERISTICHE DI COSTRUZIONE**

- MOTORE A BAGNO D'OLIO (BIODEGRADABILE E DIELETTRICO) PER RAFFREDDAMENTO E LUBRIFICAZIONE CUSCINETTI.
- DOPPIA TENUTA MECCANICA: LATO MOTORE A BAGNO D'OLIO. LATO POMPA A BAGNO D'ACQUA.
- IMMERSIONE MASSIMA: mt. 20.
- GRADO DI PROTEZIONE IP 68.
- CLASSE DI ISOLAMENTO: F.
- TEMPERATURA MAX. LIQUIDO POMPATO: 35°C.
- VERSIONI: Monofase: 220-230V/50Hz con protettore termico incorporato e quadro elettrico in materiale plastico completo di condensatore e interruttore
- CAVO STANDARD:
  - Monofase: 20 metri H07RN-F per versione normale (aut.-man).
  - Trifase: 20 metri H07RN-F

SPECIALI VOLTAGGI E FREQUENZE A RICHIESTA.

**DESIGN ENGINEERING**

- OIL BATH MOTOR (BIODEGRADABLE AND DIELECTRIC) FOR COOLING AND BEARING LUBRICATION.
- DOUBLE MECHANICAL SEALS: ENGINE FACE: OIL BATH. PUMP FACE: WATER BATH.
- PERMISSIBLE DRAUGHT OF WATER: 20 m
- IP 68 PROTECTION CLASS.
- CLASS "F" INSULATION.
- MAX. PUMPED LIQUID TEMPERATURE: 35°C
- VERSIONS: Single Phase: 220-230V/50Hz with built in thermal and plastic casing power supply box comprising capacitor and switch.
- STANDARD CABLE FEATURES:
  - Single Phase: 20 metres H07RN-F for the standard version (automatic-manual).
  - Three Phase: 20 metres H07RN-F

CUSTOMISED VOLTAGE AND FREQUENCY RATING AVAILABLE ON DEMAND.

**TABELLA MATERIALI / MATERIALS TABLE:**

Pos.	Componente - Component	Materiale - Materials
A	Carcassa esterna / External motor housing	ACCIAIO INOX AISI 304 - DIN 1.4301 / STAINLESS STEEL
B	Giranti / Impellers	ACCIAIO INOX AISI 303 - DIN 1.4005 / STAINLESS STEEL
C	Albero (lato pompa) / Shaft (pump side)	ACCIAIO INOX AISI 304 - DIN 1.4301 / STAINLESS STEEL
D	Tenuta meccanica / Mechanical seal	CARBURO DI SILICIO / SILICON CARBIDE
	Lato motore / Motor face	
	Lato pompa / Pump face	
E	O-ring	NBR
H	Carcassa motore / Motor housing	ACCIAIO INOX AISI 304 - DIN 1.4301 / STAINLESS STEEL
I	Coperchio / Cover	BRONZO / BRONZE
L	Diffusori + piattelli / Diffusers + disks	TECNOPOLIMERO / TECNOPOLYMER
N	Base d'aspirazione / Suction base	ACCIAIO INOX AISI 304 - DIN 1.4301 / STAINLESS STEEL
R	Flangia inferiore / Lower support	BRONZO / BRONZE
S	Flangia inferiore / Lower support	
V	Flangia inferiore / Lower support	

**GPV.RX 100 - 150 - 200**



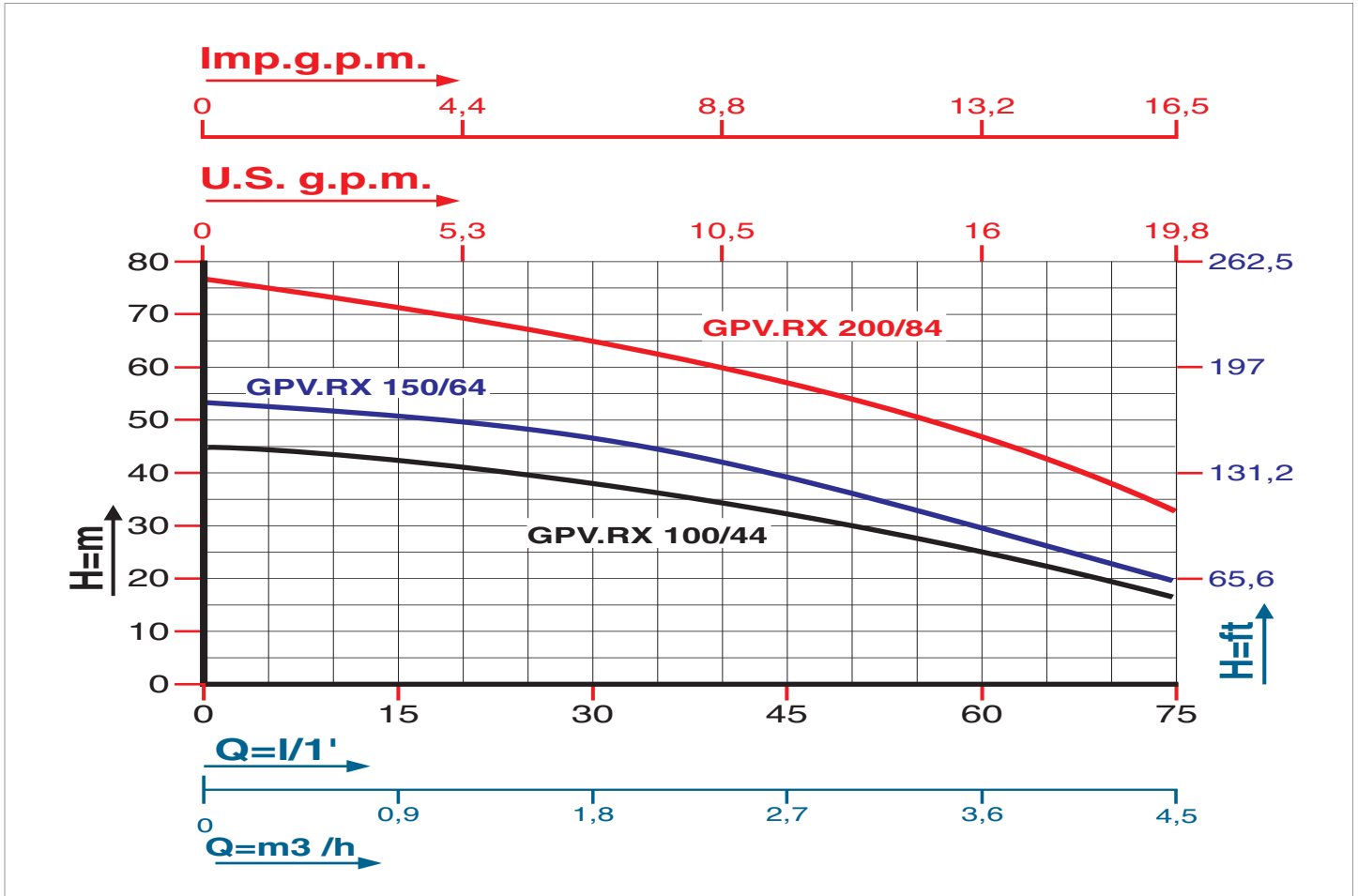

MODELLO MODEL	VOLTAGGIO VOLTAGE 50 Hz	DATI ELETTRICI / ELECTRICAL DATA					DATI IDRAULICI / HYDRAULIC DATA										
		P1 max kW	P2 nom. kW	I max HP	I max Ampere	Condensatore Capacitor µF	VC	m³/h	0	0,6	1,2	1,8	2,4	3	3,6	4,5	9,6
GPV.RX 100/44 M	1 x 220-230V	0,9	0,75	1,0	4,0	20,0	450	0	10	20	30	40	50	60	75	100	
GPV.RX 150/64 M	1 x 220-230V	1,1	1,1	1,5	5,0	20,0	450	H (m)	44,0	44,5	41,5	38,5	35,0	29,5	25,0	16,0	---
GPV.RX 200/84 M	1 x 220-230V	1,4	1,5	2,0	6,5	30,0	450	H (m)	53,0	51,5	50,0	46,5	42,0	35,0	30,0	19,0	---
								H (m)	76,5	74,0	70,0	65,0	60,0	54,0	46,0	32,5	---

PREVALENZA TOTALE in METRI COLONNA ACQUA / TOTAL PUMP HEAD AND WATER COLUMN HEIGHT IN m.

**DIMENSIONI e PESI / SIZE AND WEIGHT DATA:**

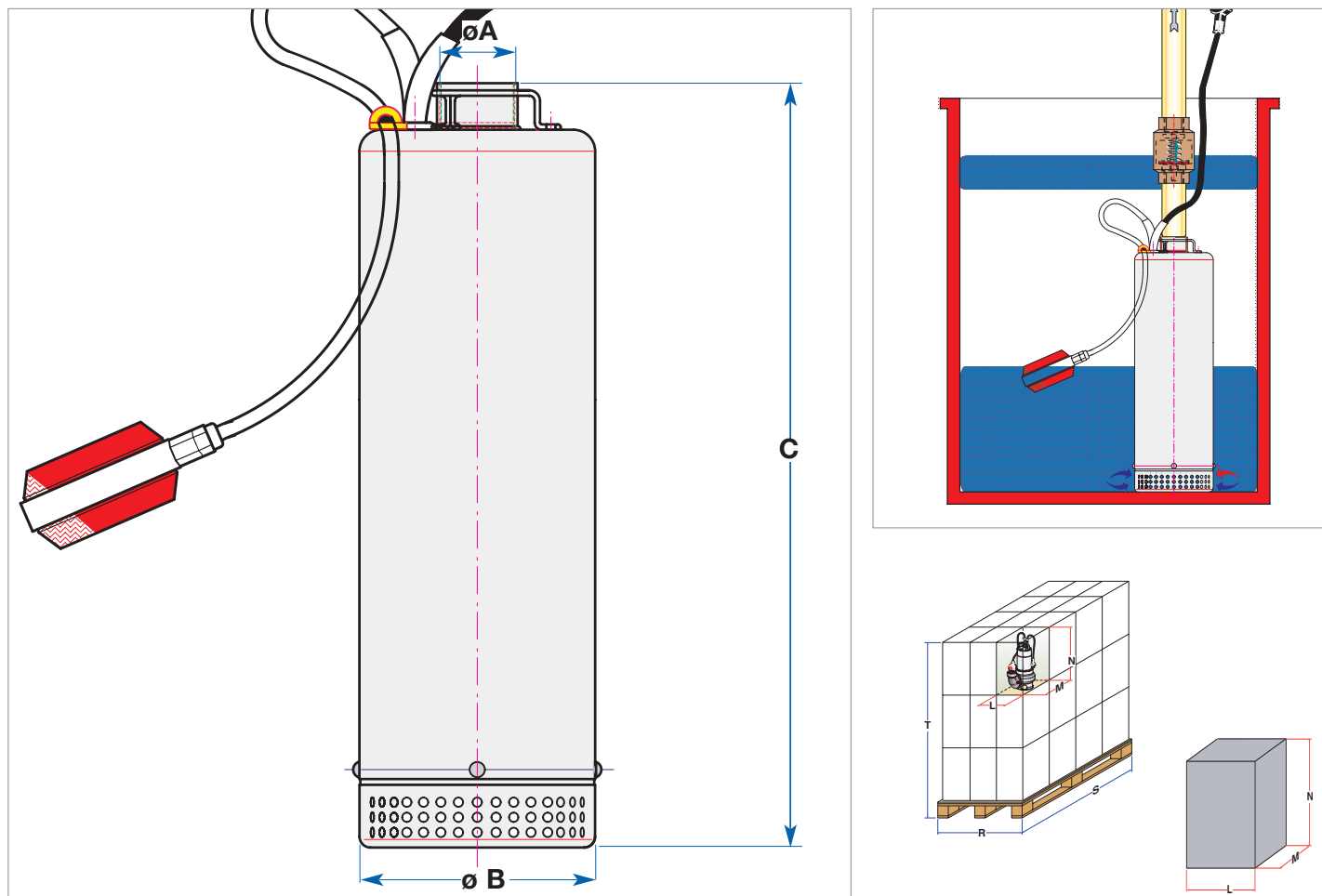

MODELLO / MODEL	DIMENSIONI POMPA in mm. / PUMP DIMENSIONS in mm.		
	A	B	C
GPV.RX 100/44 M	1" 1/4	130	434
GPV.RX 150/64 M	1" 1/4	130	458
GPV.RX 200/84 M	1" 1/4	130	530

MODELLO MODEL	DIMENSIONI SCATOLA / PACKING DIMENSIONS				DIMENSIONI PALLET / PALLET DIMENSIONS				
	L mm	M mm	N mm	Peso / Weight Kg	R mm	S mm	T mm	nr. scatole/cartons	Peso / Weight Kg
GPV.RX 100/44	455	210	250	14,6	800	1200	1500	30	465
GPV.RX 150/64	490	210	250	16,5	800	1200	1500	30	520
GPV.RX 200/84	585	210	250	18,8	800	1200	1500	30	590

# WORKER



## **ELETTROPOMPE SOMMERSIBILI MULTISTADIO VERTICALI PER POZZI DA 8 E 10 POLLICI** **VERTICAL SUBMERSIBLE MULTI STAGE ELECTRI PUMPS FOR 8 AND 10 INCH WELLS**

**PREVALENZA** ..... : 35,0 mt. ÷ 45,0 mt.  
**PORTATA** ..... : 18 m<sup>3</sup>/h  
**POTENZA NOMINALE** : 1,1 kW (1,5HP) ÷ 1,8 kW (2,5HP)

### **APPLICAZIONI**

- PARTICOLARMENTE INDICATE NEL SETTORE AGRICOLO PER IRRIGAZIONE, POMPAGGIO DI ACQUA DA VASCHE O SERBATOI DI PRIMA RACCOLTA, POZZI DA 8 A 10 POLLICI POCO PROFONDI 10-20 MT, BACINI E CORSI D'ACQUA
- MOVIMENTAZIONE NEL SETTORE INDUSTRIALE DI ACQUE DI RAFFREDDAMENTO E DI ALIMENTAZIONE E SCARICO.
- PRESSURIZZAZIONE CON POMPA INSERITA NEL SERBATOIO O POZZO

**PUMP HEAD** ..... : 35,0 mt ÷ 45,0 mt  
**DELIVERY** ..... : 18,0 m<sup>3</sup>/h  
**RATED HORSEPOWER** : 1,1 kW (1,5HP) ÷ 1,8 kW (2,5HP)

### **APPLICATIONS**

- PARTICULARLY SUITED TO THE AGRICULTURAL AND FARMING SECTORS FOR IRRIGATION PURPOSES, FOR CATCH TANK AND RESERVOIR CATCH-WATER PUMP OUT, FROM 8 TO 10 INCH WELL, WITH 10-20 MT DEEP, WATER BASIN AND WATER DRAIN FLOW PUMP OUT.
- FOR INDUSTRIAL COOLING, FEED-IN AND DISCHARGE WATER HANDLING.
- FOR PRESSURISATION, WITH TANK OR WELL PUMP INCLUSION.

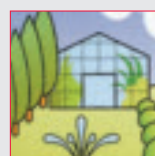
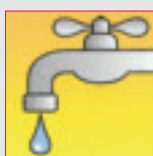

**AV ARVEN**

**CARATTERISTICHE DI COSTRUZIONE**

- MOTORE A BAGNO D'OLIO (BIODEGRADABILE E DIELETTRICO) PER RAFFREDDAMENTO E LUBRIFICAZIONE CUSCINETTI.
- DOPPIA TENUTA MECCANICA: LATO MOTORE A BAGNO D'OLIO. LATO POMPA A BAGNO D'ACQUA.
- IMMERSIONE MASSIMA: 20 mt
- GRADO DI PROTEZIONE IP 68.
- CLASSE DI ISOLAMENTO: F.
- TEMPERATURA MAX. LIQUIDO POMPATO: 35°C .
- PASSAGGIO LIBERO: PULITO.
- MONOFASE 220 - 277V/50Hz o 220 – 277V / 60 Hz :
  - con protettore termico incorporato e condensatore permanentemente inserito. (HP 1,5)
  - con protettore termico incorporato e quadro elettrico in materiale plastico completo di condensatore e interruttore. (HP 2,5)
- TRIFASE 220-277V/60Hz o 380-480V/60Hz con protezione da sovraccarico a cura dell'utente.
- CAVO STANDARD:
  - Monofase: 10 metri H07RN-F senza spina.  
10 metri H07RN-F completa di quadro elettrico con spezzone cavo 0,7 metri senza spina.
  - Trifase: 10 metri H07RN-F senza spina.

SPECIALI VOLTAGGI E FREQUENZE A RICHIESTA.

**ACCESSORI DISPONIBILI A RICHIESTA:**

- QUADRO ELETTRICO TRIFASE DI PROTEZIONE E COMANDO AUTOMATICO A MEZZO DI GALLEGGIANTE ELETTROMECCANICO.
- GALLEGGIANTE 10-20 mt. DI CAVO.
- RACCORDI E PORTA GOMMA RAPIDI DA 2" e 3" IN ALLUMINIO RAPIDO.

**DESIGN ENGINEERING**

- OIL BATH MOTOR (BIODEGRADABLE AND DIELECTRIC OIL) FOR COOLING AND BEARING LUBRICATION.
- DOUBLE MECHANICAL SEALS: ENGINE FACE: OIL BATH. PUMP FACE: WATER BATH.
- PERMISSIBLE DRAUGHT OF WATER: 20 mt
- IP 68 PROTECTION CLASS.
- CLASS "F" INSULATION.
- MAX. PUMPED LIQUID TEMPERATURE: 35°C
- BY PASS SECTION: CLEAN
- SINGLE PHASE 220 - 277V/50Hz or 220 – 277V / 60 Hz:
  - with built in thermal protection and permanent capacitor. (HP 1,5)
- - with built in thermal protection and plastic casing power supply box comprising capacitor and switch. (HP 2,5)
- THREE PHASE 220-277V/60 Hz or 380-480V/60Hz with overload protection care of the User.
- STANDARD CABLE FEATURES:
  - Single Phase: 10 metres H07RN-F without plug.  
10 metres H07RN-F complete with power supply box 0.7 m cable section, without connection plug.
  - Three phase: 10 metres H07RN-F without plug.

CUSTOMISED VOLTAGE AND FREQUENCY RATING AVAILABLE ON DEMAND.

**ACCESSORIES AVAILABLE ON DEMAND:**

- THREE PHASE ELECTRICAL SAFETY POWER SUPPLY BOX WITH AUTOMATIC ELECTROMECHANICAL FLOATER CONTROLS.
- FLOATER CONTROLS 10-20 mt. ELECTRIC CABLE.
- CONNECTION PIECES FROM 3" CONNECTING NOZZLE IN ALUMINIUM.

**TABELLA MATERIALI / MATERIALS TABLE:**

Pos.	Componente / Component		Materiale / Materials
A	Carcassa esterna External housing		ACCIAIO INOX AISI 304 - DIN 1.4301 STAINLESS STEEL
B	Girante / Impeller		
C	Albero (lato pompa) / Shaft (pump side)		ACCIAIO INOX AISI 316 - DIN 1.4401 / STAINLESS STEEL
D	Doppia tenuta meccanica Double mechanical seal	Lato pompa / Pump face	CARBURO DI SILICIO-CERAMICA SILICON CARBIDE-CERAMIC
		Lato motore / Motor face	GRAFITE-CERAMICA CARBIDE-CERAMIC
E	O-ring		NBR
H	Carcassa motore / Motor housing		ACCIAIO INOX AISI 304 - DIN 1.4301 / STAINLESS STEEL
I	Coperchio / Cover		
L	Diffusore / Diffuser		GHISA (G20) CAST IRON
M	Griglia / Grid		ACCIAIO INOX AISI 304 - DIN 1.4301 / STAINLESS STEEL
R	Flangia inferiore / Lower flange		ALLUMINIO CON TRATTAMENTO SPECIALE ALUMINIUM WITH SPECIAL TREATMENT
Y	Piattello / Disk base		ACCIAIO / STEEL

**WORKER 150 - 250**

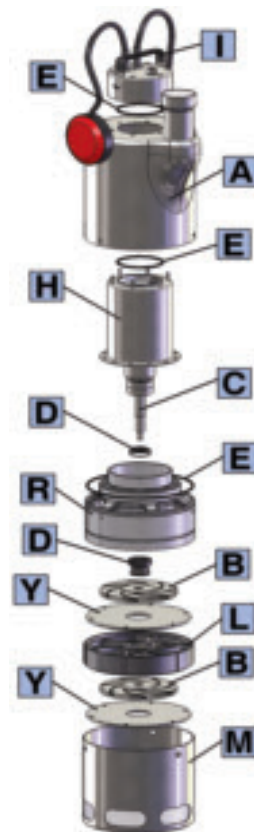



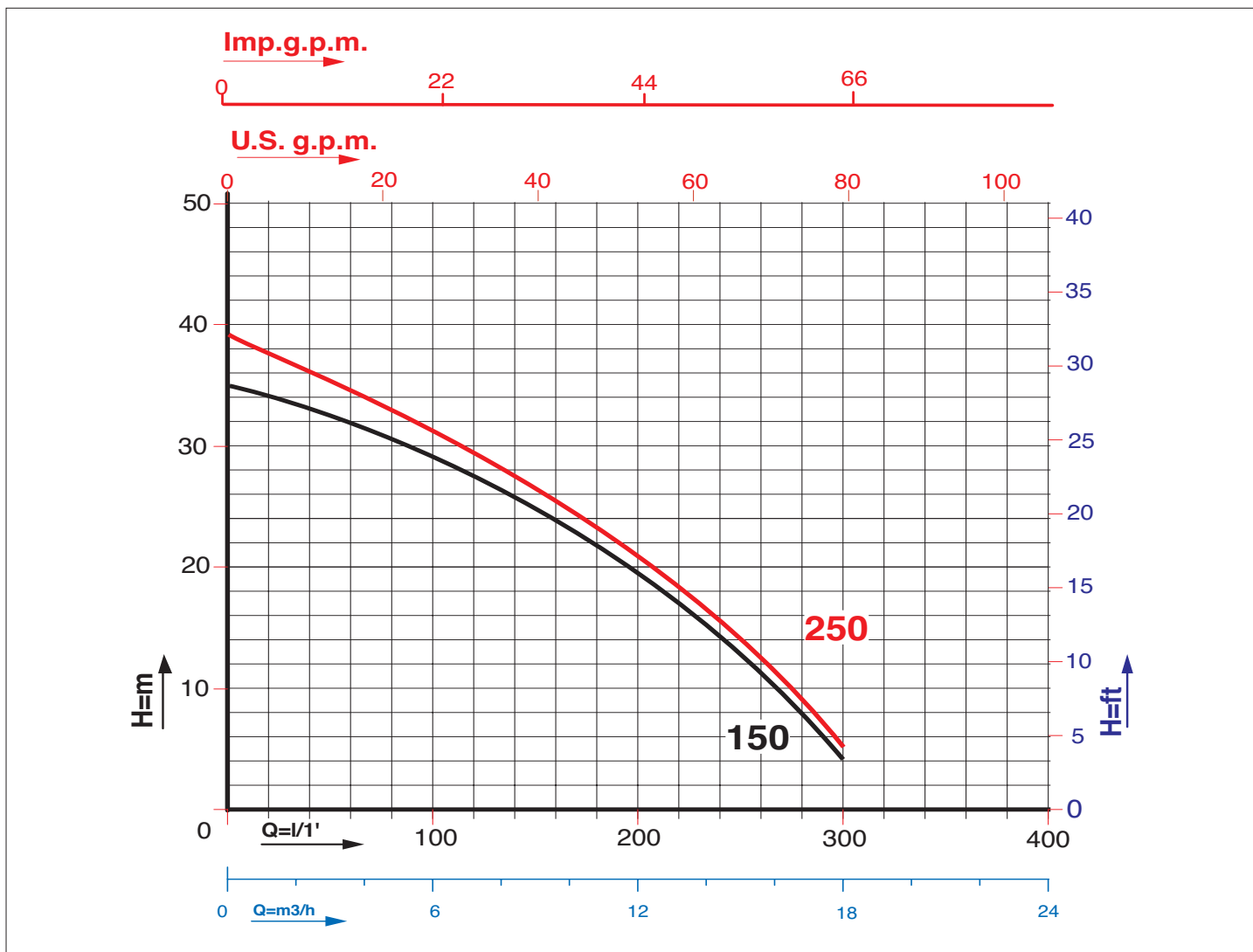

Caratteristiche di funzionamento a 3450 rpm 60Hz - Performances at 3450 rpm 60 Hz

Le prestazioni valgono per liquidi con densità  $p = 1,0 \text{ kg/dm}^3$  ed una viscosità  $v = 1 \text{ mm}^2/\text{s}$  / The performance data holds true for liquids with a  $p = 1,0 \text{ kg/dm}^3$  density and a  $v = 1 \text{ mm}^2/\text{s}$  viscosity.

MODELLO MODEL	VOLTAGGIO VOLTAGE	DATI ELETTRICI / ELECTRICAL DATA						DATI IDRAULICI / HYDRAULIC DATA						
		P1 max kW	P2 nom. kW	I max HP	I max Ampere	Condensatore Capacitor		H (m)						
						μF	VC	0	3	6	9	12	15	18
WORKER 150 M	1 x 220-230V	2,4	1,1	1,5	11,5	30	450	35,0	32,5	28,5	25,0	19,5	13,0	4,0
WORKER 150 T	3 x 380-400V	2,2	1,1	1,5	3,8	---	---	35,0	32,5	28,5	25,0	19,5	13,0	4,0
WORKER 250 M	1 x 220-230V	3,1	1,8	2,5	13,5	40	450	39,0	35,5	31,5	26,5	21,0	14,0	5,0
WORKER 250 T	3 x 380-400V	2,9	1,8	2,5	5,0	---	---	39,0	35,5	31,5	26,5	21,0	14,0	5,0

PRESSIONE TOTALE IN METRI COLONNA ACQUA  
 TOTAL PUMP HEAD AND WATER COLUMN HEIGHT IN  
 M.

**DIMENSIONI E PESI / SIZE AND WEIGHT DATA:**

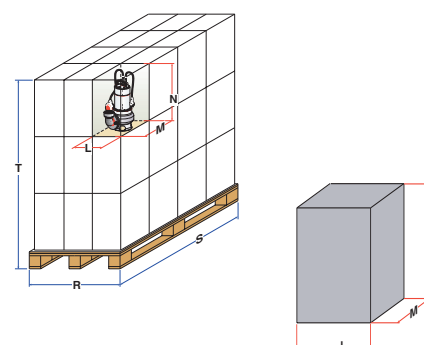
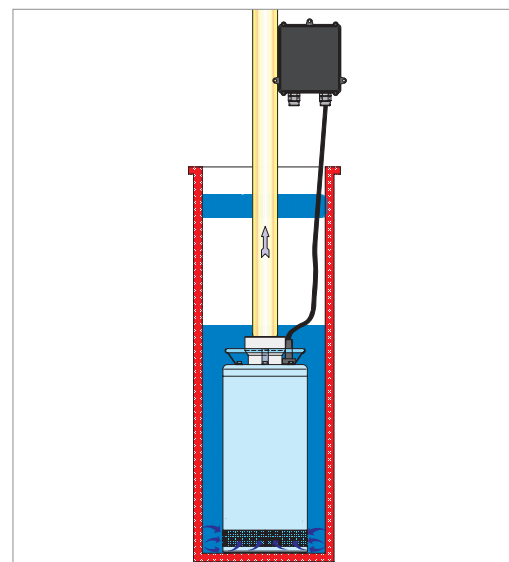
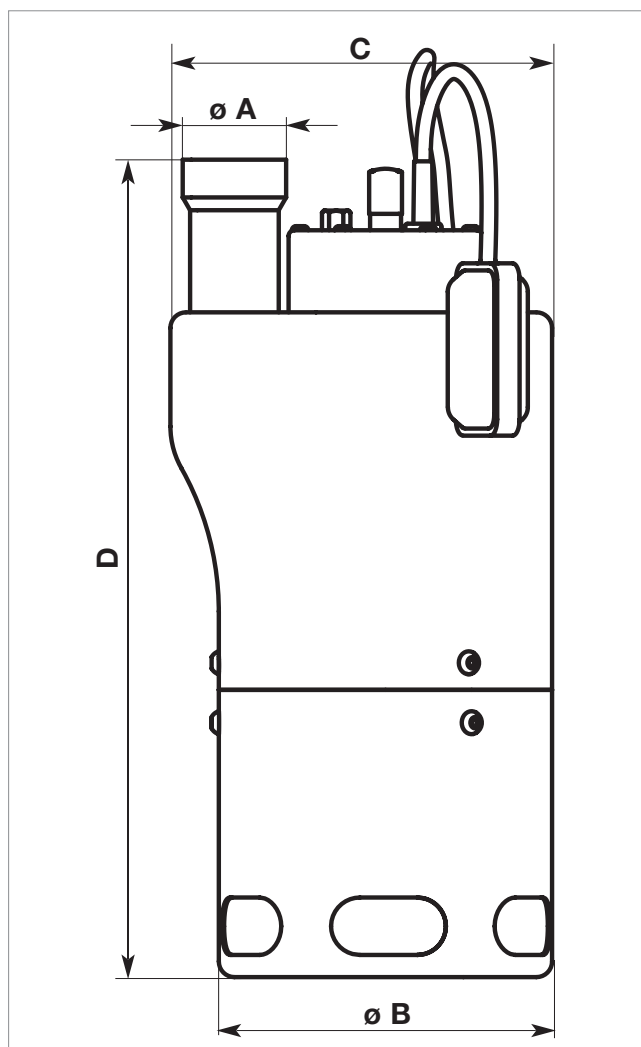

MODELLO / MODEL	DIMENSIONI POMPA in mm. / PUMP DIMENSIONS in mm.			
	A	B	C	D
WORKER 150 M	2"	203	230	490
WORKER 150 T	2"	203	230	490
WORKER 250 M	2"	203	230	490
WORKER 250 T	2"	203	230	490

MODELLO / MODEL	DIMENSIONI SCATOLA / PACKING DIMENSIONS				DIMENSIONI PALLET / PALLET DIMENSIONS				
	L	M	N	Peso / Weight	R	S	T	nr.	Peso / Weight
	mm.	mm.	mm.	Kg.	mm.	mm.	mm.	scatole/cartons	Kg.
WORKER 150 M	650	260	370	33,0	800	1200	2350	24	817
WORKER 150 T	650	260	370	33,0	800	1200	2350	24	817
WORKER 250 M	650	260	370	35,0	800	1200	2350	24	865
WORKER 250 T	650	260	370	35,0	800	1200	2350	24	865

# WORKER



## **ELETTROPOMPE SOMMERSIBILI MONOBLOCCO MULTISTADIO VERTICAL PER POZZI DA 8 e 10 POLLICI** **VERTICAL SUBMERSIBLE MULTI STAGE ELECTRIC PUMPS FOR 8 AND 10 INCH WELLS**

**PREVALENZA** ..... : 42 mt. ÷ 91 mt.  
**PORTATA** ..... : 21 m<sup>3</sup>/h ÷ 30 m<sup>3</sup>/h  
**POTENZA NOMINALE** : 2,2 kW (3HP) ÷ 7,5 kW (10HP)

**PUMP HEAD** ..... : 42,0 mt ÷ 91,0 mt  
**DELIVERY** ..... : 21,0 m<sup>3</sup>/h ÷ 30,0 m<sup>3</sup>/h  
**RATED HORSEPOWER** : 2,2 kW (1,5HP) ÷ 7,5 kW (10,0HP)

### **APPLICAZIONI**

- PARTICOLARMENTE INDICATE NEL SETTORE AGRICOLO PER IRRIGAZIONE, POMPAGGIO DI ACQUA DA VASCHE O SERBATOI DI PRIMA RACCOLTA, POZZI DA 8 A 10 POLLICI POCO PROFONDI 10-20 MT, BACINI E CORSI D'ACQUA
- MOVIMENTAZIONE NEL SETTORE INDUSTRIALE DI ACQUE DI RAFFREDDAMENTO E DI ALIMENTAZIONE E SCARICO.
- PRESSURIZZAZIONE CON POMPA INSERITA NEL SERBATOIO O POZZO
- FONTANE.

### **APPLICATIONS**

- PARTICULARLY SUITED TO THE AGRICULTURAL AND FARMING SECTORS FOR IRRIGATION PURPOSES, FOR CATCH TANK AND RESERVOIR CATCH-WATER PUMP OUT, FROM 8 TO 10 INCH WELL, WITH 10-20 MT DEEP, WATER BASIN AND WATER DRAIN FLOW PUMP OUT.
- FOR INDUSTRIAL COOLING, FEED-IN AND DISCHARGE WATER HANDLING.
- FOR PRESSURISATION, WITH TANK OR WELL PUMP INCLUSION.
- FOR FOUNTAINS.

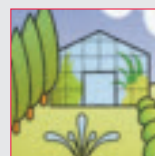
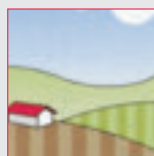
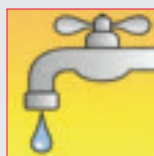

**AV ARVEN**

**CARATTERISTICHE DI COSTRUZIONE**

- MOTORE A BAGNO D'OLIO (BIODEGRADABILE E DIELETTRICO) PER RAFFREDDAMENTO E LUBRIFICAZIONE CUSCINETTI.
- DOPPIA TENUTA MECCANICA: LATO MOTORE A BAGNO D'OLIO. LATO POMPA A BAGNO D'ACQUA.
- IMMERSIONE MASSIMA: mt. 20 .
- GRADO DI PROTEZIONE IP 68 .
- CLASSE DI ISOLAMENTO: F
- TEMPERATURA MAX. LIQUIDO POMPATO: 35°C
- VERSIONI:  
Trifase: 220-277V/ 50Hz o 380 – 480V / 50Hz e 220-277V/ 60Hz o 380 – 480V /60Hz con protezione da sovraccarico a cura dell'utente
- POTENZA MOTORE: DA 3 Hp a 10 Hp SOLO VERSIONI TRIFASE.
- CAVO STANDARD:  
Trifase: 10 metri H07RN-F senza spina

SPECIALI VOLTAGGI E FREQUENZE A RICHIESTA.

**ACCESSORI DISPONIBILI A RICHIESTA:**

- QUADRO ELETTRICO TRIFASE DI PROTEZIONE E COMANDO AUTOMATICO A MEZZO DI GALLEGGIANTE ELETTROMECCANICO.
- GALLEGGIANTE 10-20 mt. DI CAVO.
- RACCORDI E PORTAGOMMA DA 3" IN ALLUMINIO

**DESIGN ENGINEERING**

- OIL BATH MOTOR (BIODEGRADABLE AND DIELECTRIC) FOR COOLING AND BEARING LUBRICATION.
- DOUBLE MECHANICAL SEALS: ENGINE FACE: OIL BATH. PUMP FACE: WATER BATH.
- PERMISSIBLE DRAUGHT OF WATER: 20 m
- IP 68 PROTECTION CLASS.
- CLASS "F" INSULATION.
- MAX. PUMPED LIQUID TEMPERATURE: 35°C
- VERSIONS:  
Three Phase: 220-277V/ 50Hz or 380 – 480V / 50Hz and 220-277V/ 60Hz or 380 – 480V /60Hz with overload protection care of the User.
- MOTOR POWER: From 3 HP to 10 HP Only three phase versions.
- STANDARD CABLE FEATURES:  
Three Phase: 10 metres H07RN-F without plug

CUSTOMISED VOLTAGE AND FREQUENCY RATING AVAILABLE ON DEMAND.

**ACCESSORIES AVAILABLE ON DEMAND:**

- THREE PHASE ELECTRICAL SAFETY POWER SUPPLY BOX WITH AUTOMATIC ELECTROMECHANICAL FLOATER CONTROLS.
- FLOATER CONTROLS 10-20 mt. ELECTRIC CABLE.
- CONNECTION PIECES FROM 3" CONNECTING NOZZLE IN ALUMINIUM.

**TABELLA MATERIALI / MATERIALS TABLE:**

Pos.	Componente / Component	Materiale / Materials
A	Carcassa esterna con calotta e maniglie <i>External housing with cap and handles</i>	ACCIAIO INOX AISI 304 DIN 1.4301 STAINLESS STEEL
B	Girante / <i>Impeller</i>	
C	Albero (lato pompa) / <i>Shaft (pump side)</i>	ACCIAIO INOX AISI 316 DIN 1.4401 / STAINLESS STEEL
D	Tenuta meccanica <i>Mechanical seal</i>	Lato pompa / <i>Pump side</i> CARBURO DI SILICIO- CARBURO DI SILICIO / <i>SILICON CARBIDE-SILICON CARBIDE</i>
		Lato motore / <i>Motor side</i> GRAFITE CERAMICA <i>CARBIDE CERAMIC</i>
E	O-ring	NBR
H	Carcassa motore / <i>Motor housing</i>	ACCIAIO INOX AISI 304 DIN 1.4301 / STAINLESS STEEL
I	Coperchio / <i>Cover</i>	GHISA (G20) CAST IRON
L	Diffusore / <i>Diffuser</i>	
M	Griglia / <i>Greed</i>	ACCIAIO INOX AISI 304 DIN 1.4301 / STAINLESS STEEL
O	Distanziale / <i>Sleeve</i>	
R	Flangia inferiore / <i>Upper flange</i>	GHISA (G20) CAST IRON
S	Flangia superiore / <i>Upper flange</i>	
K	Guarnizione / <i>Gasket</i>	NBR
V	Convogliatore / <i>Conveyor</i>	GHISA (G20) CAST IRON
Y	Piattello / <i>Disk base</i>	ACCIAIO / STEEL

**WORKER 300-400-500-750-1000**

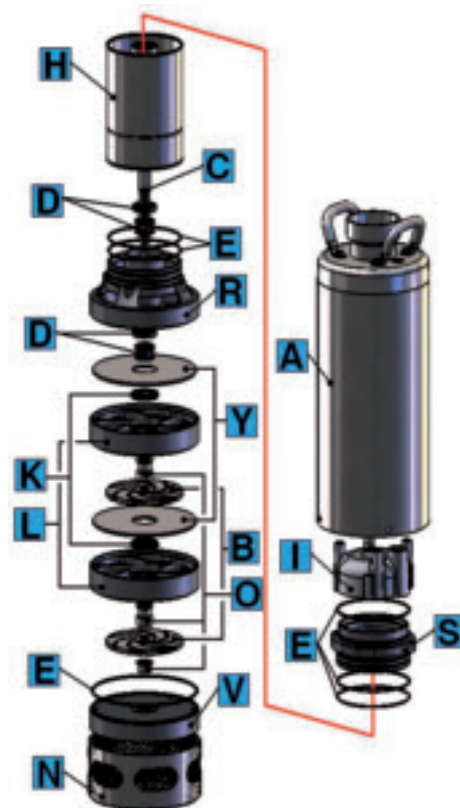

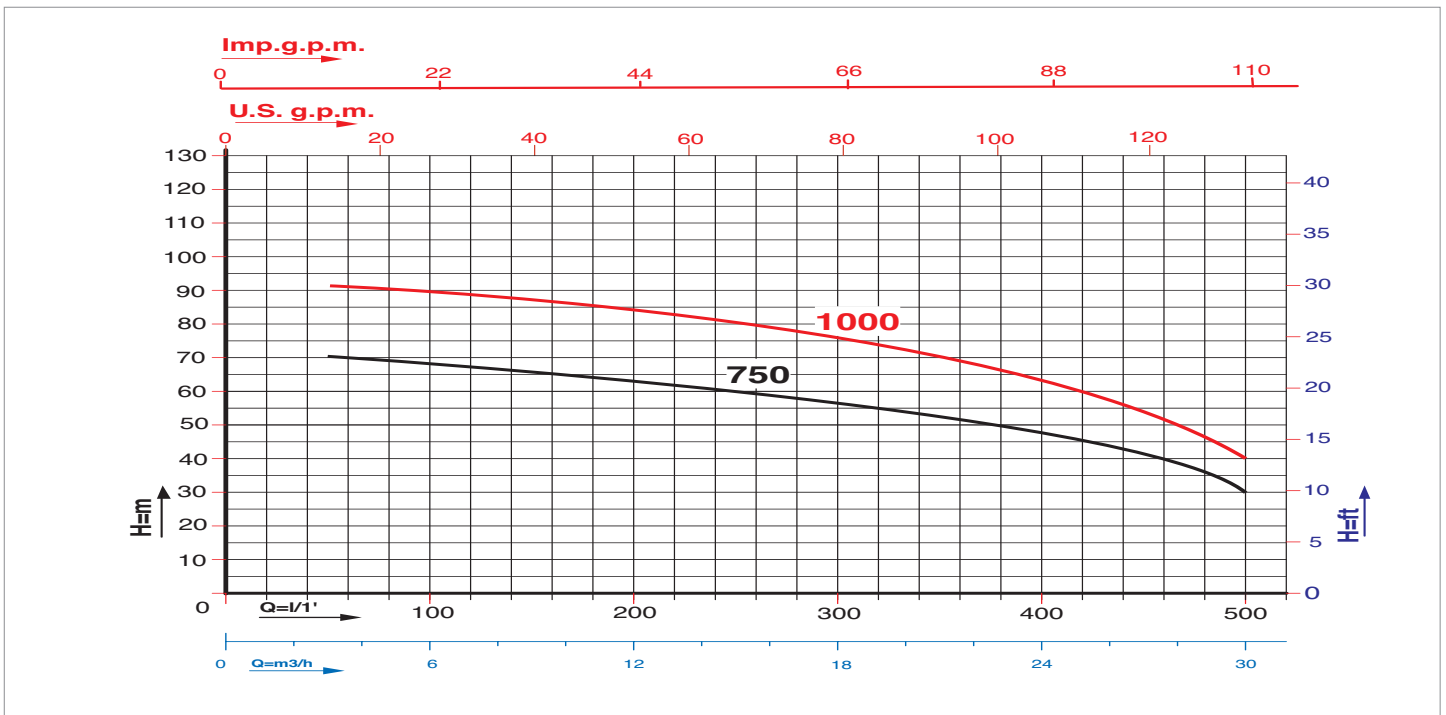
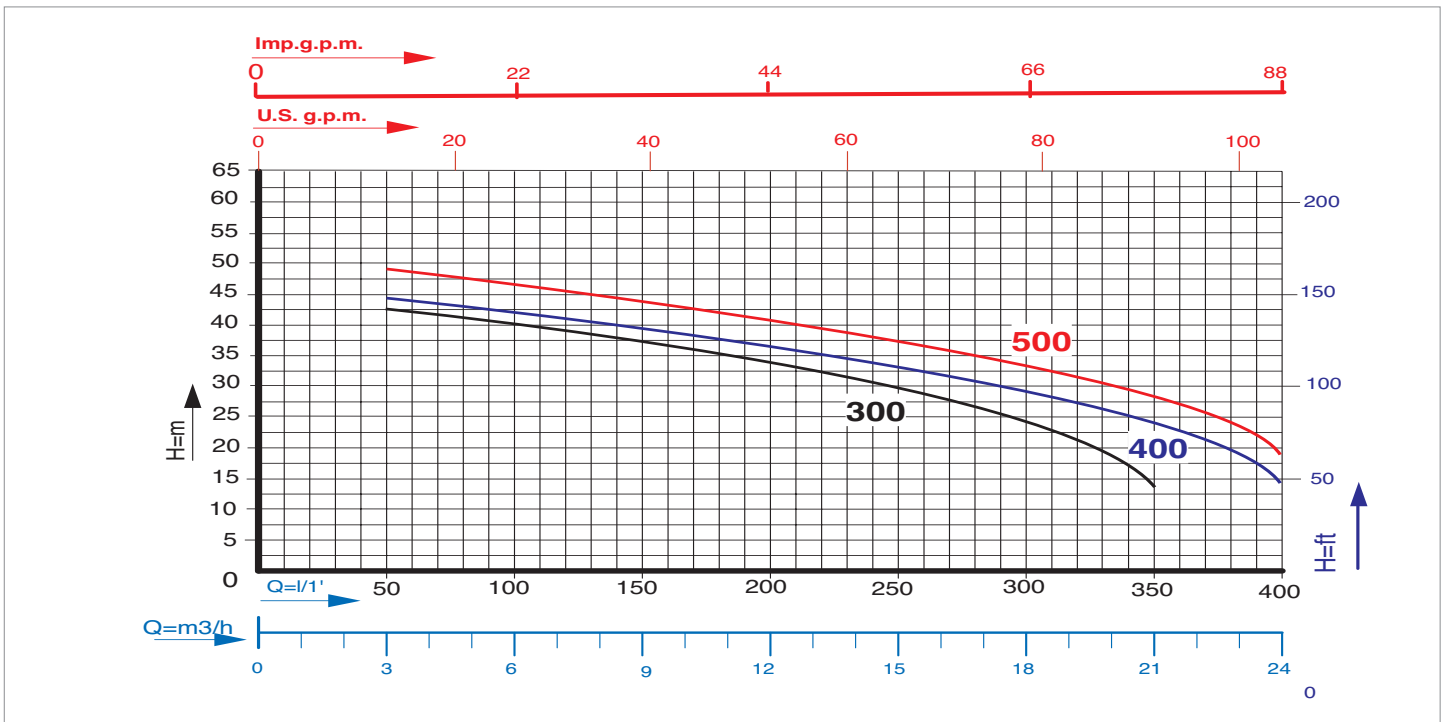

Caratteristiche di funzionamento a 2800 rpm 50Hz e 3450 rpm 60Hz - Performances at 2800 rpm 50 Hz and 3450 rpm 60 Hz  
 Le prestazioni valgono per liquidi con densità  $\rho = 1,0 \text{ kg/dm}^3$  ed una viscosità  $\nu = 1 \text{ mm}^2/\text{s}$  / The performance data holds true for liquids with a  $\rho = 1,0 \text{ kg/dm}^3$  density and a  $\nu = 1 \text{ mm}^2/\text{s}$  viscosity.

MODELLO MODEL	VOLTAGGIO VOLTAGE	DATI ELETTRICI / ELECTRICAL DATA						DATI IDRAULICI / HYDRAULIC DATA (2850 min <sup>-1</sup> )										
		P1 max kW	P2 nom. kW	I max HP	Condensatore Capacitor			m³/h	3	6	9	12	15	21	24	27	30	
WORKER 300 T	3 x 380-400V	3,0	2,2	3,0	6,0	---	---	H (m)	50	100	150	200	250	350	400	450	500	
WORKER 400 T	3 x 380-400V	3,9	3,0	4,0	6,6	---	---		42,0	40,0	37,0	33,0	28,0	13,0				
WORKER 500 T	3 x 380-400V	4,9	3,7	5,0	9,8	---	---		44,0	42,0	38,0	36,0	32,0	22,0	14,0			
WORKER 750 T	3 x 380-400V	7,3	5,5	7,5	12,6	---	---		49,0	47,0	43,0	41,0	37,0	27,0	18,0			
WORKER 1000 T	3 x 380-400V	10,1	7,5	10,0	15,6	---	---		70,0	68,0	65,0	63,0	60,0	52,0	48,0	40,0	30,0	
									91,0	90,0	86,0	84,0	80,0	69,0	64,0	53,0	40,0	

PRESSIONE TOTALE IN METRI COLONNA ACQUA / TOTAL PUMP HEAD AND WATER COLUMN HEIGHT IN M.



**DIMENSIONI e PESI / SIZE AND WEIGHT DATA:**

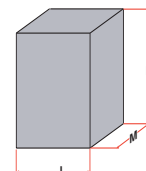
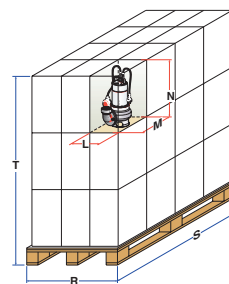
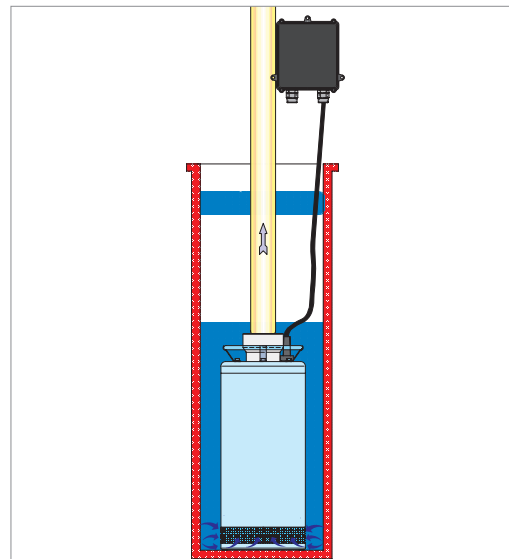
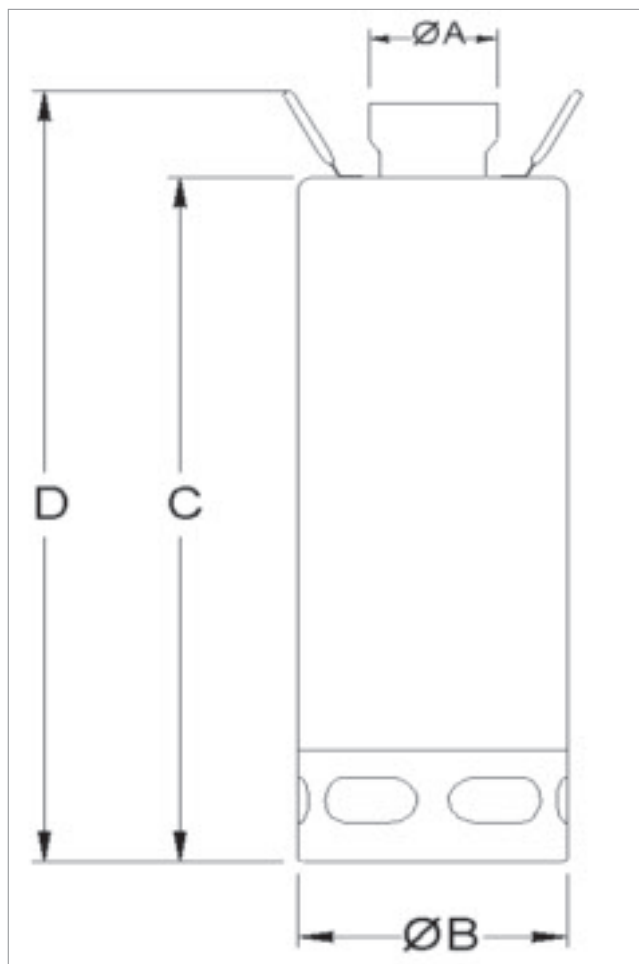

MODELLO / MODEL	DIMENSIONI POMPA in mm. / PUMP DIMENSIONS in mm.			
	A	B	C	D
WORKER 300 T	3"	204	584	651
WORKER 400 T	3"	204	584	651
WORKER 500 T	3"	204	584	651
WORKER 750 T	3"	204	584	651
WORKER 1000 T	3"	204	584	651

MODELLO / MODEL	DIMENSIONI SCATOLA / PACKING DIMENSIONS				DIMENSIONI PALLET / PALLET DIMENSIONS				
	L mm.	M mm.	N mm.	Peso / Weight Kg.	R mm.	S mm.	T mm.	nr. scatole/cartons	Peso / Weight Kg.
WORKER 300 T	720	400	260	38	800	1200	900	25	955
WORKER 400 T	720	400	260	43	800	1200	900	25	1080
WORKER 500 T	720	400	260	48	800	1200	900	25	1205
WORKER 750 T	900	400	260	57	800	1200	900	18	1031
WORKER 1000 T	900	400	260	68	800	1200	900	18	1229

**SISTEMI DI DISCESA (DN 50) PER IMPIANTI FISSI**  
**DOWN STROKE GUIDE RAIL SYSTEM (DN 50)**  
**FOR FIXED PLANTS**

MODELLO / MODEL	DIMENSIONI POMPA in mm. PUMP DIMENSIONS in mm.			ø solidi ø solids (mm)	D
	DNM	B	C		
DUMPER 150	2"	429	464	8	3/4"
DUMPER 200	2"	429	464	8	
DUMPER 300	2"	429	464	8	

MODELLO / MODEL	DIMENSIONI POMPA in mm. PUMP DIMENSIONS in mm.			ø solidi ø solids (mm)	D
	DNM	B	C		
ARVEX 80	2"	388	408	50	3/4"
ARVEX 100	2"	397	408	50	
ARVEX 150	2"	397	448	50	
ARVEX 200	2"	397	448	50	

MODELLO / MODEL	DIMENSIONI POMPA in mm. PUMP DIMENSIONS in mm.			ø solidi ø solids (mm)	D
	DNM	B	C		
CUTTER 140	2"	415	400	---	3/4"
CUTTER 150	2"	433	464	---	
CUTTER 200	2"	433	464	---	
CUTTER 300	2"	433	464	---	

\* = RIDUZIONE DA 1 1/2 A 2" / REDUCTION FROM 1 1/2 TO 2"

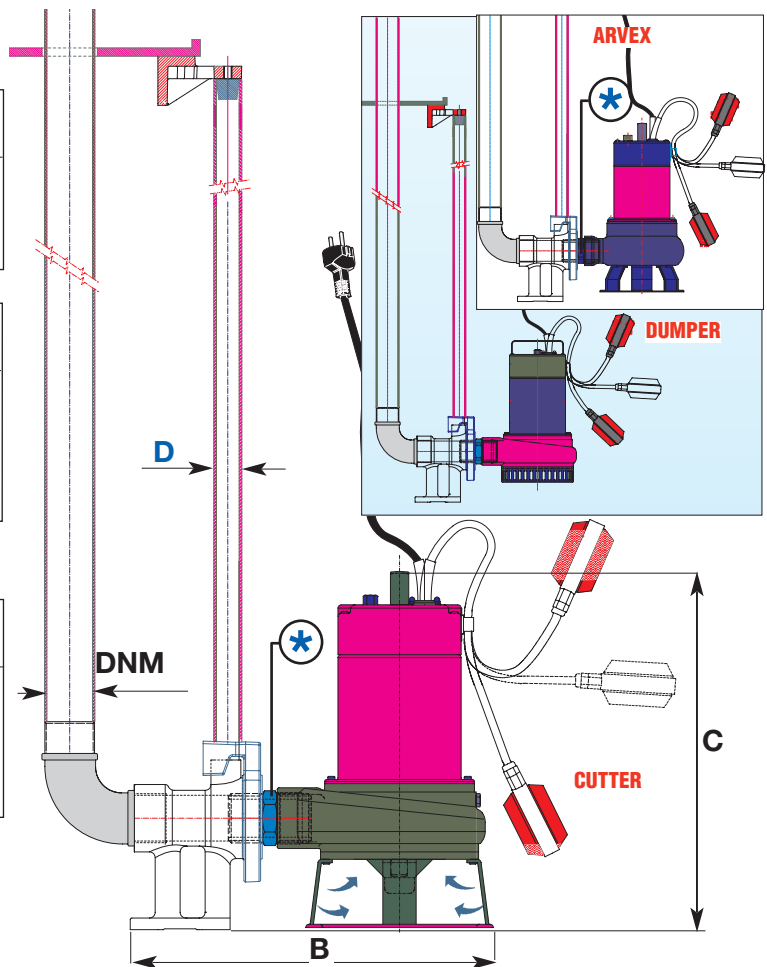

**SERIE SERIES TIGER 80F - 100F - 150F - 200F - 300F - 400F**

**SISTEMI DI DISCESA (DN 50) PER IMPIANTI FISSI**  
**DOWN STROKE GUIDE RAIL SYSTEM (DN 50)**  
**FOR FIXED PLANTS**

MODELLO / MODEL	DIMENSIONI POMPA in mm. PUMP DIMENSIONS in mm.			ø solidi ø solids (mm)	D
	DNM	B	C		
TIGER 80F	2"	354	420	35	3/4"
TIGER 100F	2"	354	420	50	
TIGER 150F	2"*	415	508	50*	
TIGER 200F	2"*	415	508	50*	

\* = SOLO PER IMPIANTI FISSI / ONLY FOR FIXED PLANTS

**SISTEMI DI DISCESA (DN 80) PER IMPIANTI FISSI**  
**DOWN STROKE GUIDE RAIL SYSTEM (DN 80)**  
**FOR FIXED PLANTS**

MODELLO / MODEL	DIMENSIONI POMPA in mm. PUMP DIMENSIONS in mm.			ø solidi ø solids (mm)	D
	DNM	B	C		
TIGER 300F	3"	529	545	80	1"
TIGER 400F	3"	529	670	80	

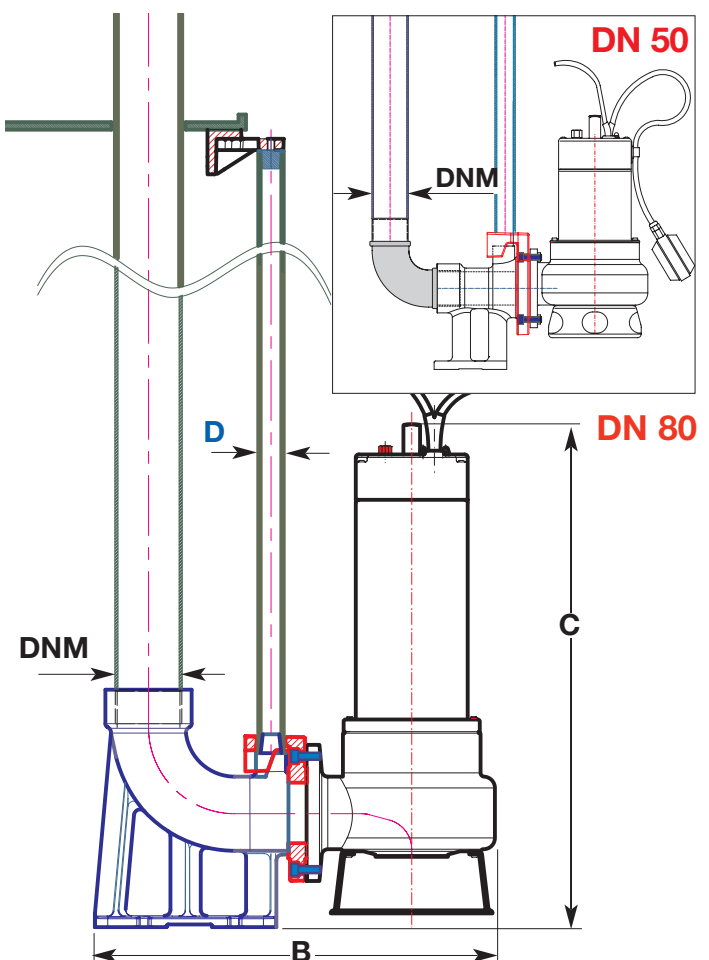

**SISTEMI DI DISCESA (DN 50) PER IMPIANTI FISSI**  
**DOWN STROKE GUIDE RAIL SYSTEM (DN 50)**  
**FOR FIXED PLANTS**

MODELLO / MODEL	DIMENSIONI POMPA in mm. PUMP DIMENSIONS in mm.			ø solidi ø solids (mm)	D
	DNM	B	C		
SKIPPER 80F	2"	352	406	45	3/4"
SKIPPER 100F	2"	352	406	45	
SKIPPER 150F	2"*	401	497	50*	
SKIPPER 200F	2"*	401	497	50*	

\* = SOLO PER IMPIANTI FISSI / ONLY FOR FIXED PLANTS

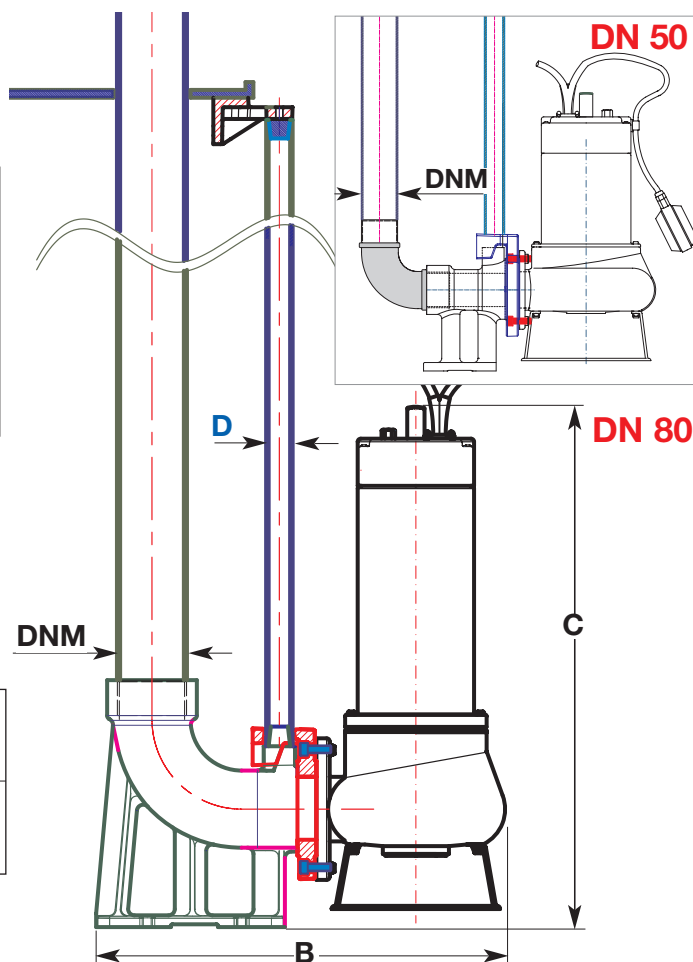

**SISTEMI DI DISCESA (DN 80) PER IMPIANTI FISSI**  
**DOWN STROKE GUIDE RAIL SYSTEM (DN80)**  
**FOR FIXED PLANTS**

MODELLO / MODEL	DIMENSIONI POMPA in mm. PUMP DIMENSIONS in mm.			ø solidi ø solids (mm)	D
	DNM	B	C		
SKIPPER 300F	3"	520	549	80	1"
SKIPPER 400F	3"	520	670	80	

SERIE SERIES RIVER / TENAX 150F - 200F - 300F - 400F - 600F MONOCANALI SINGLE CHANNEL

**SISTEMI DI DISCESA (DN 50) PER IMPIANTI FISSI**  
**DOWN STROKE GUIDE RAIL SYSTEM (DN 50) FOR**  
**FIXED PLANTS**

MODELLO / MODEL	DIMENSIONI POMPA PUMP DIMENSIONS in mm.			ø solidi ø solids (mm)	D
	DNM	B	C		
RIVER 150F <b>a</b>	2"*	256	514	50	3/4"
RIVER 200F <b>a</b>	2"*	256	514	50*	
TENAX 150F <b>a</b>	2"*	389	500	50	
TENAX 200F <b>a</b>	2"*	389	500	50*	

\* = SOLO PER IMPIANTI FISSI / ONLY FOR FIXED PLANTS

**SISTEMI DI DISCESA (DN 80) PER IMPIANTI FISSI**  
**DOWN STROKE GUIDE RAIL SYSTEM (DN 80)**  
**FOR FIXED PLANTS**

MODELLO / MODEL	DIMENSIONI POMPA in mm/ PUMP DIMENSIONS in mm.			ø solidi ø solids (mm)	D
	DNM	B	C		
RIVER 300F <b>c</b>	3"	623	665	50	1"
RIVER 400F <b>c</b>	3"	623	665	50	
RIVER 600F <b>c</b>	3"	623	665	50	
TENAX 300F <b>c</b>	3"	604	657	50	
TENAX 400F <b>c</b>	3"	604	657	50	
TENAX 600F <b>c</b>	3"	604	657	50	

**c** = Monocanale chiusa / Close single channel  
**a** = Monocanale aperta / Open single channel

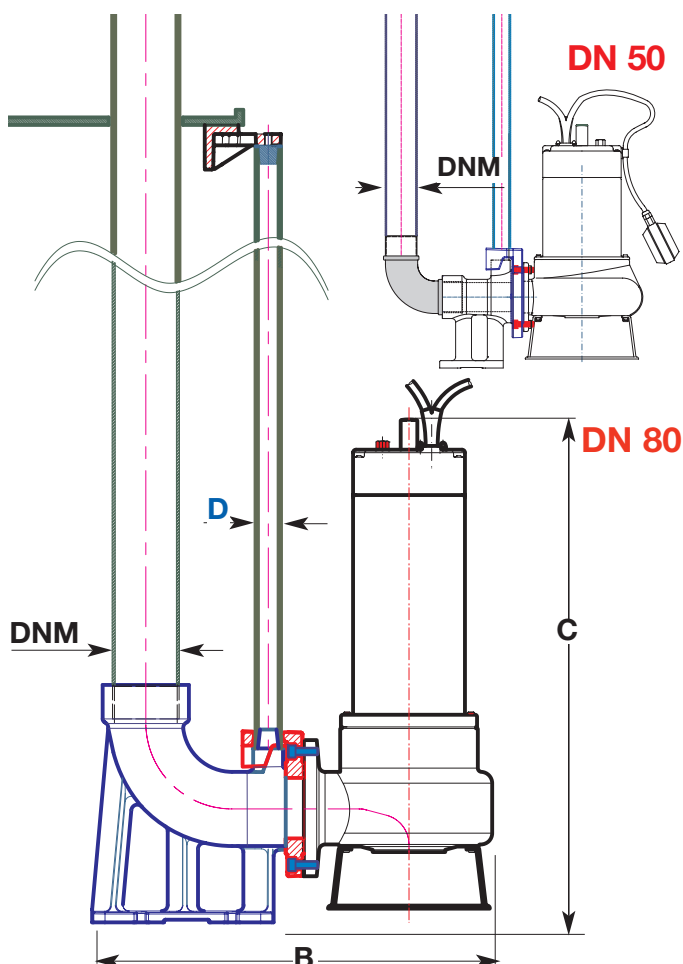

D = DIMENSIONI TUBI DISCESA / DOWN TUBES DIMENSIONS

**STAZIONI AUTOMATICHE PER LA RACCOLTA E IL SOLLEVAMENTO DI ACQUE CARICHE**

**AUTOMATIC PUMPING STATIONS FOR THE COLLECTION AND LIFTING OF FOUL WASTEWATER**

**APPLICAZIONI**

UTILIZZATE PER LA RACCOLTA DI ACQUE DOMESTICHE USATE DA IMMETTERE IN COLLETTORI DI SCARICO SITUATI SU DI UN DISLIVELLO SUPERIORE, O COMUNQUE PRIVI DI CADENZA GRAVITAZIONALE

**APPLICATIONS**

IMPLEMENTED FOR THE COLLECTION OF DOMESTIC WASTEWATER AND USED AS A LIFT STATION TO PUMP THE WASTEWATER INTO DISCHARGE COLLECTORS LOCATED AT HIGHER LEVELS OR THAT DO NOT ANYWAY HAVE A GRAVITATIONAL DROP.

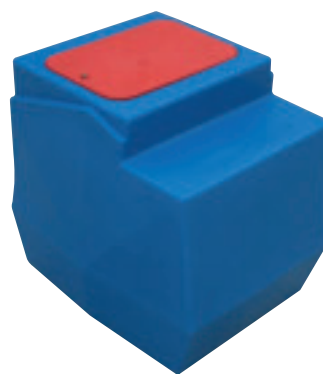

**TABELLA DATI TECNICI / TECHNICAL TABLE**

BOX - 1		CARATTERISTICHE / FEATURES					ACCESSORI / ACCESSORIES					
		P2 (kw)	HP	Q max (l/min)	H max (m)	TIPOLOGIA GIRANTE IMPELLER TYPE	QUADRO ELETTRICO CONTROL BOARD	GALEGG. PREMONTATO SU POMPA FLOAT PREASSEMBLED ON PUMP	N°2 GALLEGGIANTE (10 MT CAVO) FLOAT (10 MT CABLE)	VALVOLA DI NON RITORNO NON RETURN VALVE	GALLEGGIANTE DI EMERGENZA EMERGENCY FLOAT	KIT ALLARME (BLOCCO TERMICO) SOUND SIGNAL WITH FLASHING SOUND SIGNAL
TIGER 80F M	SISTEMI DI DISCESA DN 50 / GUIDE RAIL SYSTEM DN 50	MONOFASE 1-PHASE	0,6	0,8	260	7	VORTEX		x			
TIGER 100F M			0,75	1	350	8	VORTEX	*	x		*	
TIGER 140F M			1,1	1,5	450	11	VORTEX		x			
TIGER 80F T		TRIFASE 3-PHASE	3-PHASE	0,6	0,8	260	7	VORTEX	x		x	
TIGER 100F T				0,75	1	350	8	VORTEX	x		x	
TIGER 140F T				1,1	1,5	450	11	VORTEX	x		x	*
TIGER 190F T				1,5	2	500	13	VORTEX	x		x	
ARVEX BC 100 M		MONOFASE 1-PHASE	1-PHASE	0,75	1	500	11,5	BICANAL		x		
ARVEX BC 150 M				1,1	1,5	600	14,5	BICANAL	*	x		*
ARVEX BC 100 T				0,75	1	500	11,5	BICANAL	x		x	
ARVEX BC 150 T		TRIFASE 3-PHASE	3-PHASE	1,1	1,5	600	14,5	BICANAL	x		x	
ARVEX BC 200 T				1,5	2	700	15,5	BICANAL	x		x	*

**DIMENSIONI IN mm / DIMENSIONS IN mm**

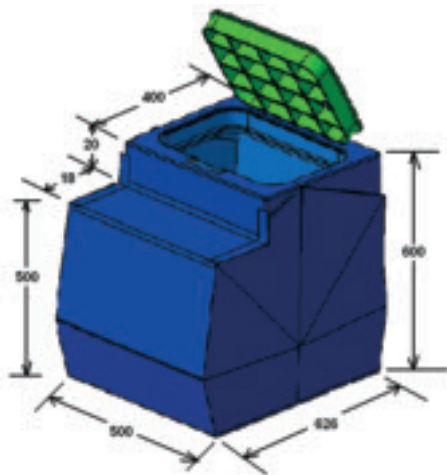

**INSTALLAZIONE / INSTALLATION**

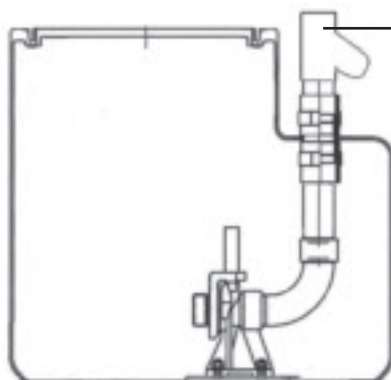

VALVOLA DI RITEGNO A PALLA CHECK BALL VALVE

X Accessori inclusi  
Included accessories

\* Accessori opzionali vedi pagina 205  
Optional accessories see page 205



**STAZIONI AUTOMATICHE PER LA RACCOLTA E IL SOLLEVAMENTO DI ACQUE CARICHE**

**AUTOMATIC PUMPING STATIONS FOR THE COLLECTION AND LIFTING OF FOUL WASTEWATER**

**APPLICAZIONI**

UTILIZZATE PER LA RACCOLTA DI ACQUE DOMESTICHE USATE DA IMMETTERE IN COLLETTORI DI SCARICO SITUATI SU DI UN DISLIVELLO SUPERIORE, O COMUNQUE PRIVI DI CADENZA GRAVITAZIONALE

**APPLICATIONS**

IMPLEMENTED FOR THE COLLECTION OF DOMESTIC WASTEWATER AND USED AS A LIFT STATION TO PUMP THE WASTEWATER INTO DISCHARGE COLLECTORS LOCATED AT HIGHER LEVELS OR THAT DO NOT ANYWAY HAVE A GRAVITATIONAL DROP.



POMPE SOMMERGIBILI INOX  
SUBMERSIBLE INOX PUMPS

**TABELLA DATI TECNICI / TECHNICAL TABLE**

BOX - 2		CARATTERISTICHE / FEATURES					ACCESSORI / ACCESSORIES						
		P2 (kw)	HP	q max (l/min)	H max (m)	TIPOLOGIA GIRANTE IMPELLER TYPE	QUADRO ELETTRICO CONTROL BOARD	GALLEG. PREMONTATO SU POMPA FLOAT PREASSEMBLED ON PUMP	N°3 GALLEGGIANTE (10 MTCAVO) FLOAT (10 MTCABLE)	VALVOLA DI NON RITORNO NON RETURN VALVE	GALLEGGIANTE DI EMERGENZA EMERGENCY FLOAT	KIT ALLARME (BLOCCO TERMICO) SOUND SIGNAL WITH FLASHING SOUND SIGNAL	
SISTEMI DI DISCESA DN 50 / GUIDE RAIL SYSTEM DN 50	MONOFASE 1 - PHASE	TIGER 80F M	2x0,6	2x0,8	520	7	VORTEX		x		x		
		TIGER 100F M	2x0,75	2x1	700	8	VORTEX	*	x	*	x		*
		TIGER 140F M	2x1,1	2x1,5	900	11	VORTEX		x		x		
	TRIFASE 3 - PHASE	TIGER 80F T	2x0,6	2x0,8	520	7	VORTEX	x		x	x	x	x
		TIGER 100F T	2x0,75	2x1	700	8	VORTEX	x		x	x	x	x
		TIGER 140F T	2x1,1	2x1,5	900	11	VORTEX	x		x	x	x	x
		TIGER 190F T	2x1,5	2x2,2	1000	13	VORTEX	x		x	x	x	x
	MONOFASE 1 - PHASE	ARVEX BC 100 M	2x0,75	2x1	1000	11,5	BICANAL	*	x	*			*
		ARVEX BC 150 M	2x1,1	2x1,5	1200	14,5	BICANAL		x				
	TRIFASE 3 - PHASE	ARVEX BC 100 T	2x0,75	2x1	1000	11,5	BICANAL	x		x	x	x	x
		ARVEX BC 150 T	2x1,1	2x1,5	1200	14,5	BICANAL	x		x	x	x	x
		ARVEX BC 200 T	2x1,5	2x2	1400	15,5	BICANAL	x		x	x	x	x

**DIMENSIONI IN mm / DIMENSIONS IN mm**

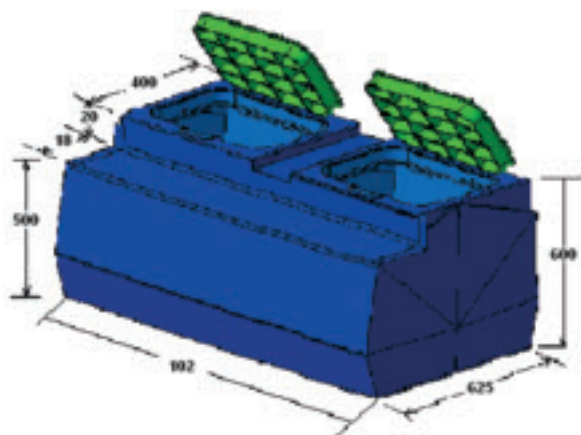

**INSTALLAZIONE / INSTALLATION**

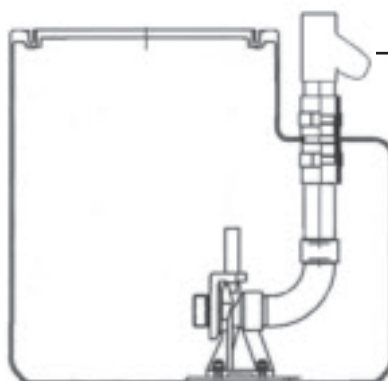

VALVOLA DI RITEGNO A PALLA  
CHECK BALL VALVE

Accessori inclusi  
X Included accessories

\* Accessori opzionali vedi pagina 205  
\* Optionals accessories see page 205





# TURBO 200 - 250



## ELETTROPOMPE SOMMERSIBILI MONOBLOCCO MULTISTADIO VERTICALI IN GHISA VERTICAL SUBMERSIBLE MULTI STAGE ELECTRIC PUMPS IN CAST IRON

**PREVALENZA** ..... : 39,5 mt. ÷ 44 mt.  
**PORTATA** ..... : 18 m<sup>3</sup>/h  
**POTENZA NOMINALE** : 1,5 kW (2,0HP) ÷ 2,25 kW (3,0HP)

**PUMP HEAD** ..... : 39,5 mt ÷ 44,0 mt  
**DELIVERY**..... : 18,0 m<sup>3</sup>/h  
**RATED HORSEPOWER** : 1,5kW (2,0HP) ÷ 2,25 kW (3,0HP)

### APPLICAZIONI

- PARTICOLARMENTE INDICATE NEL SETTORE AGRICOLO PER IRRIGAZIONE, POMPAGGIO DI ACQUA DA VASCHE O SERBATOI DI PRIMA RACCOLTA, POZZI DA 8 A 10 POLLICI POCO PROFONDI 10-20 MT, BACINI E CORSI D'ACQUA
- MOVIMENTAZIONE NEL SETTORE INDUSTRIALE DI ACQUE DI RAFREDDAMENTO E DI ALIMENTAZIONE E SCARICO.
- PRESSURIZZAZIONE CON POMPA INSERITA NEL SERBATOIO O POZZO
- FONTANE.

### APPLICATIONS

- PARTICULARLY SUITED TO THE AGRICULTURAL AND FARMING SECTORS FOR IRRIGATION PURPOSES, FOR CATCH TANK AND RESERVOIR CATCH-WATER PUMP OUT, FROM 8 TO 10 INCH WELL, WITH 10-20 MT DEEP, WATER BASIN AND WATER DRAIN FLOW PUMP OUT.
- FOR INDUSTRIAL COOLING, FEED-IN AND DISCHARGE WATER HANDLING.
- FOR PRESSURISATION, WITH TANK OR WELL PUMP INCLUSION.
- FOR FOUNTAINS.

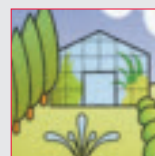
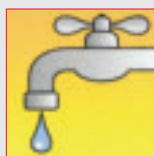

**AVARVEN**

**CARATTERISTICHE DI COSTRUZIONE**

- MOTORE A BAGNO D'OLIO (BIODEGRADABILE E DIELETTRICO) PER RAFFREDDAMENTO E LUBRIFICAZIONE CUSCINETTI.
  - DOPPIO ANELLO DI TENUTA LATO MOTORE.
  - TENUTA MECCANICA A BAGNO D'OLIO.
  - IMMERSIONE MASSIMA: mt. 20.
  - GRADO DI PROTEZIONE IP 68.
  - CLASSE DI ISOLAMENTO: F.
  - TEMPERATURA MAX. LIQUIDO POMPATO: 35°C.
  - VERSIONI:  
 Monofase: 220-277V / 50Hz con protettore termico incorporato.  
 Trifase: 220-277V/ 50Hz o 380 – 480V /50Hz con protezione da sovraccarico a cura dell'utente.
  - VERSIONI MONOFASI AUTOMATICHE CON GALLEGGIANTE fino a 2,0 HP  
 VERSIONI MONOFASI da 3,0 Hp solo MANUALI SENZA GALLEGGIANTE.
  - CAVO STANDARD:  
 Monofase: H07RN-F 10mt completa di quadro elettrico con spezzone 0,7 metri senza spina.  
 Trifase: H07RN-F 10mt senza spina.
- SPECIALI VOLTAGGI E FREQUENZE A RICHIESTA.

**DESIGN ENGINEERING**

- OIL BATH MOTOR (BIODEGRADABLE AND DIELECTRIC) FOR COOLING AND BEARING LUBRICATION.
  - DOUBLE SEALING RING - ENGINE FACE.
  - OIL BATH MECHANICAL SEALS.
  - PERMISSIBLE DRAUGHT OF WATER: 20 m.
  - IP 68 PROTECTION CLASS.
  - CLASS "F" INSULATION.
  - MAX. PUMPED LIQUID TEMPERATURE: 35°C.
  - VERSIONS:  
 Single Phase: 220-277V/50Hz with built in thermal protection.  
 Three Phases: 220-277V/50Hz or 380-480V/50Hz with overload protection care of the User.
  - AUTOMATIC SINGLE PHASE VERSIONS up to 1,1 kW (2,0 HP).  
 SINGLE PHASE VERSIONS from 1,5 kW (3,0 HP) only manual, without floater
  - STANDARD CABLE FEATURES:  
 Single Phase: H07RN-F 10mt complete with power supply box 0,7 m cable section, without connection plug.  
 Three Phases: H07RN-F 10mt without connection plug.
- CUSTOMISED VOLTAGE AND FREQUENCY RATING AVAILABLE ON DEMAND.

**TABELLA MATERIALI / MATERIALS TABLE:**

Pos.	Componente / Component	Materiale / Materials
A	Coperchio / Cover	GHISA (G20) / CAST IRON
B	Guarnizione / Gasket	GOMMA DIELETTRICA DIELECTRIC RUBBER
C	Carcassa motore / Motor housing	GHISA (G20) / CAST IRON
D	Albero / Shaft	ACCIAIO INOX AISI 416 DIN 1.4005 / STAINLESS STEEL
E	Tenuta meccanica / Mechanical seal	Lato Motore / Motor side DOPPIO ANELLO DI TENUTA NBR NBR DOUBLE SEALING RING
		Lato pompa / Pump side CARBURO DI SILICIO/ALLUMINA SILICON CARBIDE-ALUMINA
F	O-ring	NBR
G	Flangia inferiore / Upper flange	GHISA (G20) / CAST IRON
H	Girante / Impeller	ACCIAIO INOX AISI 304 DIN 1.4301 / STAINLESS STEEL
I	Diffusore / Diffuser	TECNOPLIMERO/TECNOPOLYMER
L	Piattello / Disk base	ACCIAIO / STEEL
M	Griglia / Greed	ACCIAIO INOX AISI 304 DIN 1.4301 / STAINLESS STEEL

**TURBO 200 - 250**

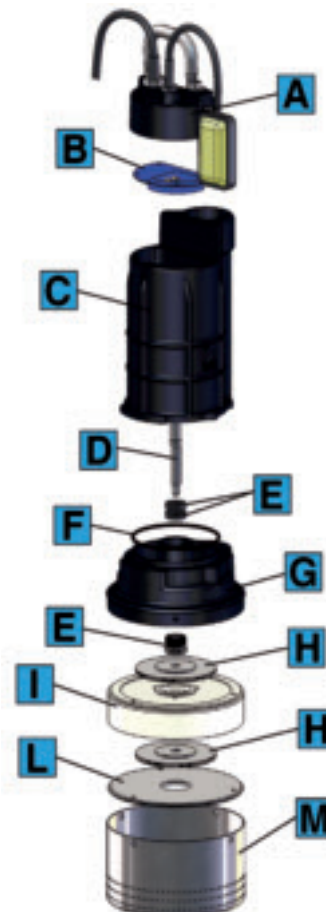

POMPE SOMMERGIBILI IN GHISA  
SUBMERSIBLE PUMPS IN CAST IRON

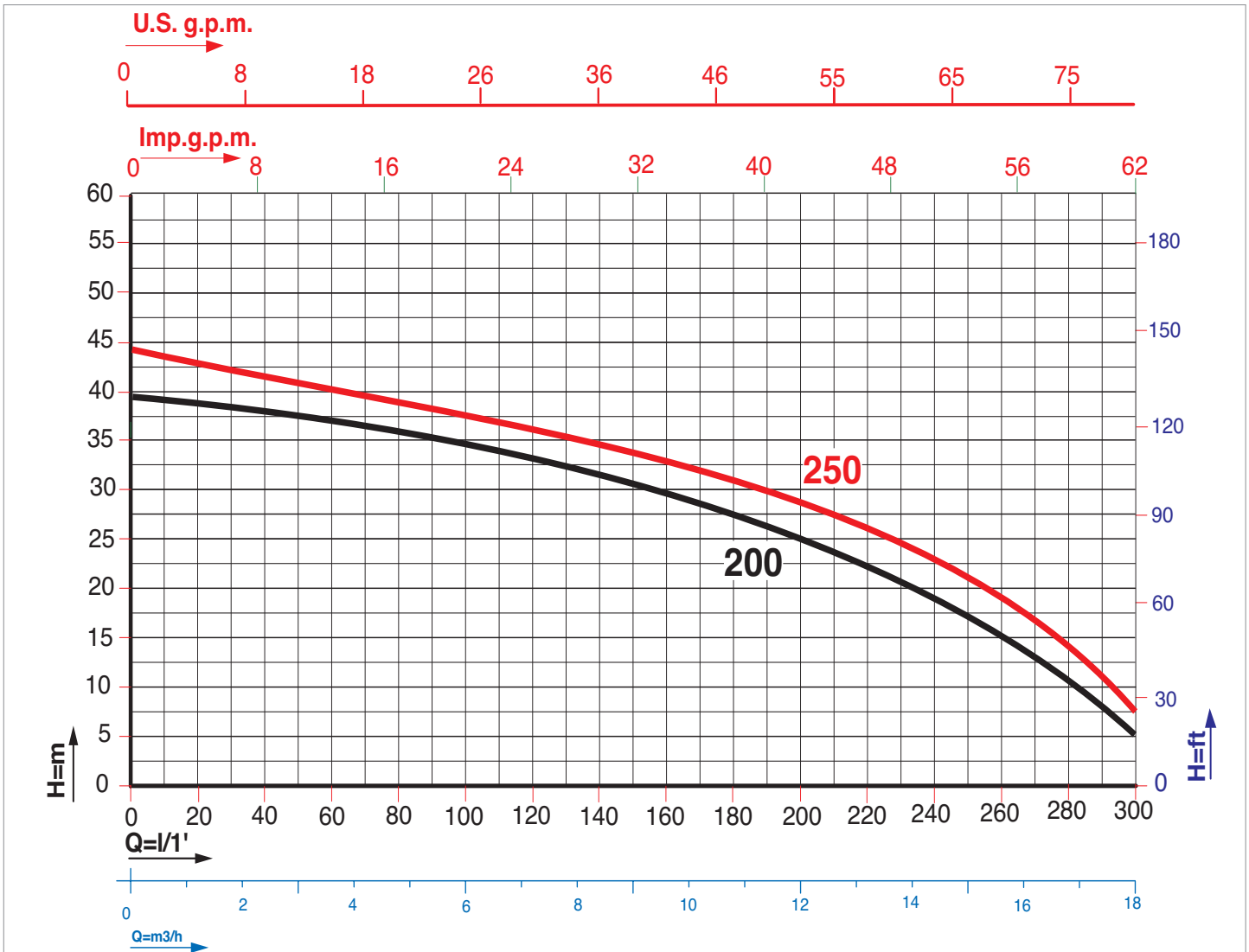

Caratteristiche di funzionamento a 2800 rpm 50Hz - Performances at 2800 rpm 50 Hz

Le prestazioni valgono per liquidi con densità  $\rho = 1,0 \text{ kg/dm}^3$  ed una viscosità  $\nu = 1 \text{ mm}^2/\text{s}$  / The performance data holds true for liquids with a  $\rho = 1,0 \text{ kg/dm}^3$  density and a  $\nu = 1 \text{ mm}^2/\text{s}$  viscosity.

MODELLO MODEL	VOLTAGGIO VOLTAGE 50 Hz	DATI ELETTRICI / ELECTRICAL DATA					DATI IDRAULICI / HYDRAULIC DATA							
		P1max kW	P2 nom.		I max Ampere	Condensatore Capacitor		H (m)						
			kW	HP		$\mu\text{F}$	VC	0	3	6	9	12	15	18
TURBO 200 M	1 x 220-230V	2,9	1,5	2,0	15,0	40	450	39,5	37,5	34,5	30,0	25,0	16,0	5,0
TURBO 200 T	3 x 380-400V	2,7	1,5	2,0	5,0	---	---	39,5	37,5	34,5	30,0	25,0	16,0	5,0
TURBO 250 M	1 x 220-230V	4,0	2,25	3,0	18,0	40	450	44,0	41,0	37,0	34,0	28,5	20,5	7,0
TURBO 250 T	3 x 380-400V	3,8	2,25	3,0	6,5	---	---	44,0	41,0	37,0	34,0	28,5	20,5	7,0

PRESSIONE TOTALE IN METRI COLONNA ACQUA  
TOTAL PUMP HEAD AND WATER COLUMN HEIGHT IN m.

**DIMENSIONI e PESI / SIZE AND WEIGHT DATA:**

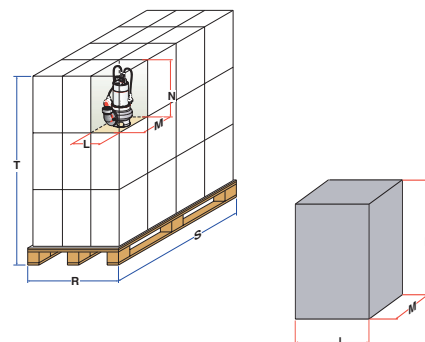
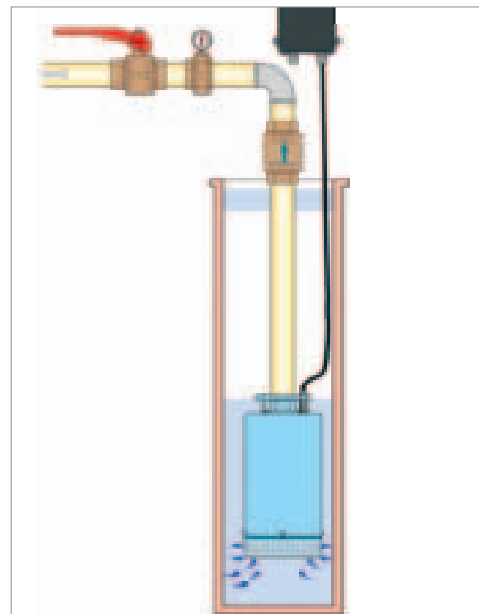
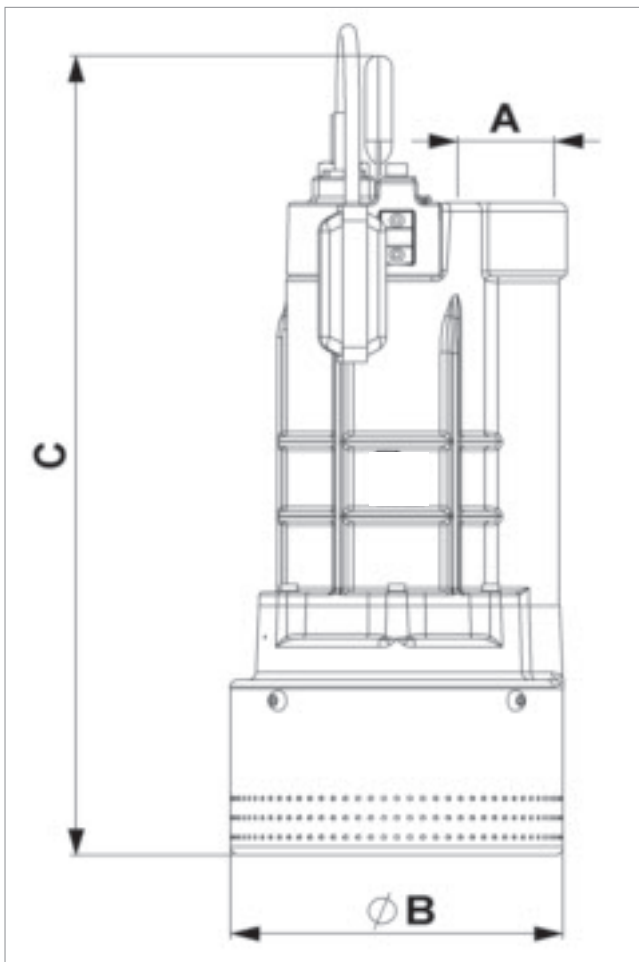

MODELLO / MODEL	DIMENSIONI POMPA in mm. / PUMP DIMENSIONS in mm.		
	A	B	C
TURBO 200	2''	203	550,5
TURBO 250	2''	203	550,5

MODELLO / MODEL	DIMENSIONI SCATOLA / PACKING DIMENSIONS				DIMENSIONI PALLET / PALLET DIMENSIONS				
	L	M	N	Peso / Weight	R	S	T	nr.	Peso / Weight
	mm.	mm.	mm.	Kg.	mm.	mm.	mm.	scatole/cartons	Kg.
TURBO 200	580	260	370	38,0	800	1200	2060	28	1092
TURBO 250	580	260	370	38,0	800	1200	2060	28	1092

# TURBO 300-400-500



## ELETTROPOMPE SOMMERSIBILI MONOBLOCCO MULTISTADIO VERTICALI VERTICAL SUBMERSIBLE MULTI STAGE ELECTRIC PUMPS

**PREVALENZA** ..... : 45 ÷ 54 mt.  
**PORTATA** ..... : 24 ÷ 30 m<sup>3</sup>/h  
**POTENZA NOMINALE** : 2,2 kW (3HP) ÷ 3,7 kW (5 HP)

**PUMP HEAD**..... : 45,0 mt ÷ 54m0 mt  
**DELIVERY**..... : 24,0 m<sup>3</sup>/h ÷ 30,0 m<sup>3</sup>/h  
**RATED HORSEPOWER** : 2,2 kW (3,0HP) ÷ 3,7 kW (5,0HP)

### APPLICAZIONI

- PARTICOLARMENTE INDICATE NEL SETTORE AGRICOLO PER IRRIGAZIONE, POMPAGGIO DI ACQUA DA VASCHE O SERBATOI DI PRIMA RACCOLTA, POZZI DA 8 A 10 POLLICI POCO PROFONDI 10-20 MT, BACINI E CORSI D'ACQUA
- MOVIMENTAZIONE NEL SETTORE INDUSTRIALE DI ACQUE DI RAFFREDDAMENTO E DI ALIMENTAZIONE E SCARICO.
- PRESSURIZZAZIONE CON POMPA INSERITA NEL SERBATOIO O POZZO
- FONTANE.

### APPLICATIONS

- PARTICULARLY SUITED TO THE AGRICULTURAL AND FARMING SECTORS FOR IRRIGATION PURPOSES, FOR CATCH TANK AND RESERVOIR CATCH-WATER PUMP OUT, FROM 8 TO 10 INCH WELL, WITH 10-20 MT DEEP, WATER BASIN AND WATER DRAIN FLOW PUMP OUT.
- FOR INDUSTRIAL COOLING, FEED-IN AND DISCHARGE WATER HANDLING.
- FOR PRESSURISATION, WITH TANK OR WELL PUMP INCLUSION.
- FOR FOUNTAINS.

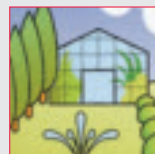
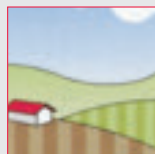
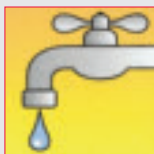

**AV ARVEN**



**CARATTERISTICHE DI COSTRUZIONE**

- MOTORE A BAGNO D'OLIO (BIODEGRADABILE E DIELETTRICO) PER RAFFREDDAMENTO E LUBRIFICAZIONE CUSCINETTI.
- ANELLO DI TENUTA LATO MOTORE
- TENUTA MECCANICA A BAGNO D'OLIO.
- IMMERSIONE MASSIMA: mt. 20.
- GRADO DI PROTEZIONE IP 68.
- CLASSE DI ISOLAMENTO: F.
- TEMPERATURA MAX. LIQUIDO POMPATO: 35°C.
- VERSIONI:  
 Monofase: 220-2770V/ 50Hz (SOLO VERSIONE 3HP).  
 Trifase: 380-400V/ 50Hz con protezione da sovraccarico a cura dell'utente.
- CAVO STANDARD:  
 Monofase: 10 mt H07RN-F senza spina (SOLO VERSIONE 3HP).  
 Trifase: 10 mt H07RN-F senza spina.

**OPZIONI:**

- CAVO PIU' LUNGO SU RICHIESTA.
- SPECIALE VOLTAGGIO E FREQUENZE A RICHIESTA.

**ACCESSORI DISPONIBILI A RICHIESTA:**

- QUADRO ELETTRICO TRIFASE DI PROTEZIONE E COMANDO AUTOMATICO A MEZZO GALLEGGIANTE ELETTROMECCANICO.
- GALLEGGIANTE 10-20mt. DI CAVO.
- RACCORDI IN ALLUMINIO.
- RIDUZIONE DA 3" A 2".

**DESIGN ENGINEERING**

- OIL BATH MOTOR (BIODEGRADABLE AND DIELECTRIC) FOR COOLING AND BEARING LUBRICATION.
- SEALING RING - ENGINE FACE.
- OIL BATH MECHANICAL SEALS.
- PERMISSIBLE EIGHT OF WATER: 20 m.
- IP 68 PROTECTION CLASS.
- CLASS "F" INSULATION.
- MAX. PUMPED LIQUID TEMPERATURE: 35°C.
- VERSIONS:  
 Single Phase: 220-277V/50Hz (ONLY 3HP VERSION)  
 Three Phases: 380-400V/50Hz with overload protection care of the User.
- STANDARD CABLE FEATURES:  
 Single Phase: 10 mt H07RN-F without connection plug (ONLY 3HP VERSION).  
 Three Phases: 10 mt H07RN-F without connection plug.

**OPTIONS:**

- CABLE LONGER THAN STANDARD VERSION ON REQUEST.
- CUSTOMIZE VOLTAGE AND FREQUENCY RATING AVAILABLE ON DEMAND.

**ACCESSORIES AVAILABLE ON DEMAND:**

- THREE PHASES ELECTRICAL SAFETY POWER SUPPLY BOX WITH AUTOMATIC ELECTROMECHANICAL FLOATER CONTROLS.
- FLOATER CONTROLS 10-20mt. ELECTRIC CABLE.
- ALUMINIUM CONNECTION PIECES.
- RIDUCTION FROM 3" TO 2".

**TABELLA MATERIALI / MATERIALS TABLE:**

Pos.	Componente / Component	Materiale / Materials
A	Coperchio / Cover	GHISA (G20) / CAST IRON
B	Guarnizione / Gasket	GOMMA DIELETTRICA DIELECTRIC RUBBER
C	Carcassa motore / Motor housing	GHISA (G20) / CAST IRON
D	Albero (lato pompa) / Shaft (pump side)	ACCIAIO INOX AISI 316 DIN 1.4401 / STAINLESS STEEL
E	Tenuta meccanica / Mechanical seal	Lato Motore / Motor side ANELLO DI TENUTA NBR NBR SEALING RING
		Lato pompa / Pump side CARBURO DI SILICIO SILICON CARBIDE
G	Flangia inferiore / Upper flange	GHISA (G20) / CAST IRON
H	Girante / Impeller	ACCIAIO INOX AISI 304 DIN 1.4301 / STAINLESS STEEL
I	Diffusore / Diffuser	GHISA (G20) / CAST IRON
L	Piattello / Disk	ACCIAIO / STEEL
M	Griglia / Greed	
N	Piatto / Disk base	GHISA (G20) / CAST IRON

**TURBO 300-400-500**

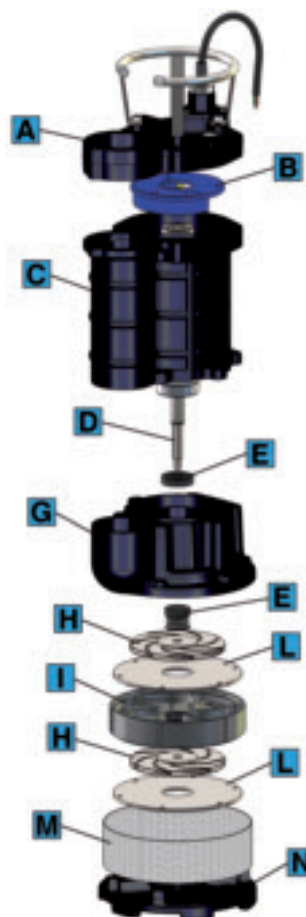

POMPE SOMMERSIBILI IN GHISA  
SUBMERSIBLE PUMPS IN CAST IRON

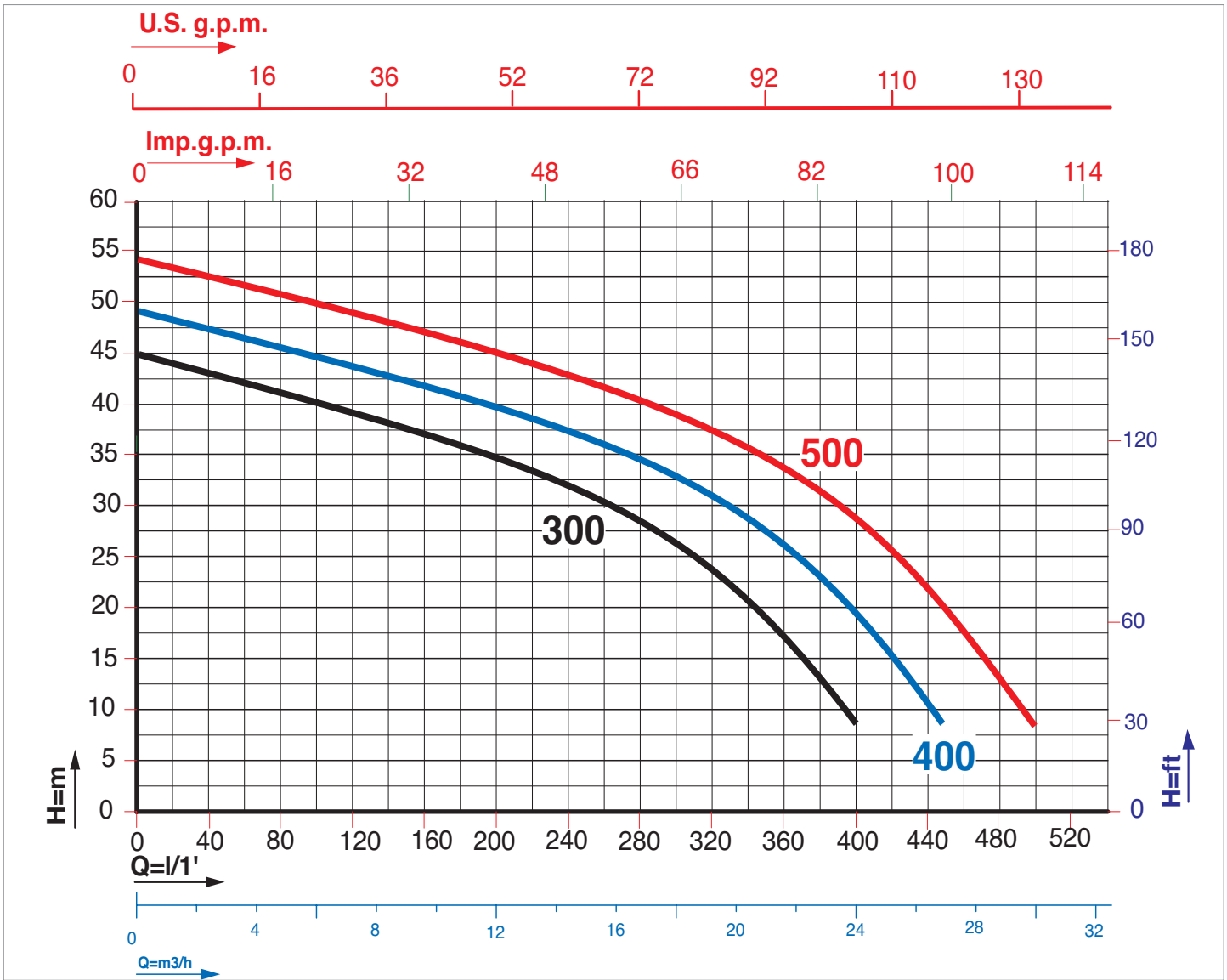

Caratteristiche di funzionamento a 2850 rpm 50Hz - Performances at 2850 rpm 50 Hz

Le prestazioni valgono per liquidi con densità  $\rho = 1,0 \text{ kg/dm}^3$  ed una viscosità  $\nu = 1 \text{ mm}^2/\text{s}$  / The performance data holds true for liquids with a  $\rho = 1,0 \text{ kg/dm}^3$  density and a  $\nu = 1 \text{ mm}^2/\text{s}$  viscosity.

MODELLO MODEL	VOLTAGGIO VOLTAGE 50 Hz	DATI ELETTRICI / ELECTRICAL DATA						DATI IDRAULICI / HYDRAULIC DATA								
		P1 max		P2 nom.		I max	Condensatore Capacitor		m³/h		24		27		30	
		kW	kW	HP	Ampere	µF	VC	l/min.	50	150	250	400	450	500		
<b>TURBO 300 M</b>	1 x 220-230V	4,5	2,2	3,0	19,0	---	450	<b>H (m)</b>	<b>43,0</b>	<b>37,5</b>	<b>31,0</b>	<b>8,0</b>	---	---		
<b>TURBO 300 T</b>	3 x 380-400V	4,0	2,2	3,0	7,0	---	---		<b>43,0</b>	<b>37,5</b>	<b>31,0</b>	<b>8,0</b>	---	---		
<b>TURBO 400 T</b>	3 x 380-400V	5,0	3,0	4,0	8,8	---	---		<b>47,0</b>	<b>42,5</b>	<b>37,0</b>	<b>19,5</b>	<b>8,0</b>	---		
<b>TURBO 500 T</b>	3 x 380-400V	6,0	3,7	5,0	9,8	---	---		<b>52,0</b>	<b>47,0</b>	<b>42,0</b>	<b>28,0</b>	<b>20,0</b>	<b>8,0</b>		

PRESSIONE TOTALE IN METRI COLONNA ACQUA  
TOTAL PUMP HEAD AND WATER COLUMN HEIGHT IN m.

**DIMENSIONI e PESI / SIZE AND WEIGHT DATA:**

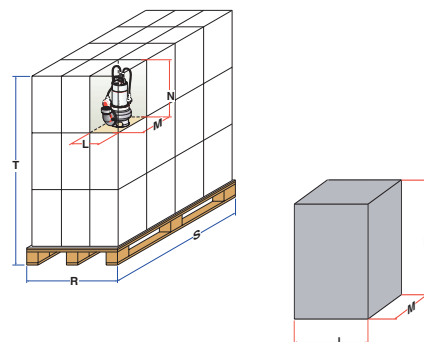
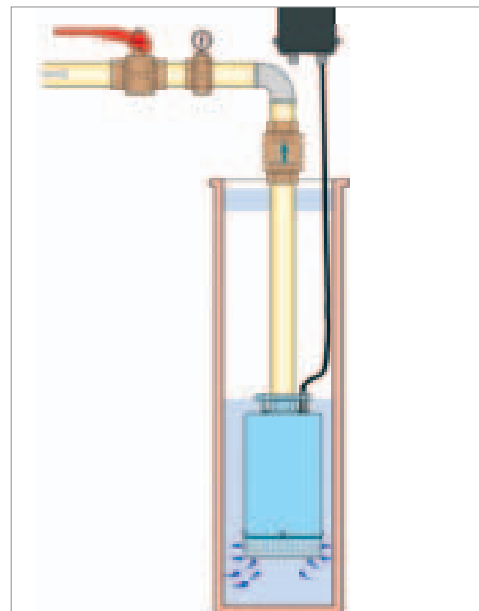
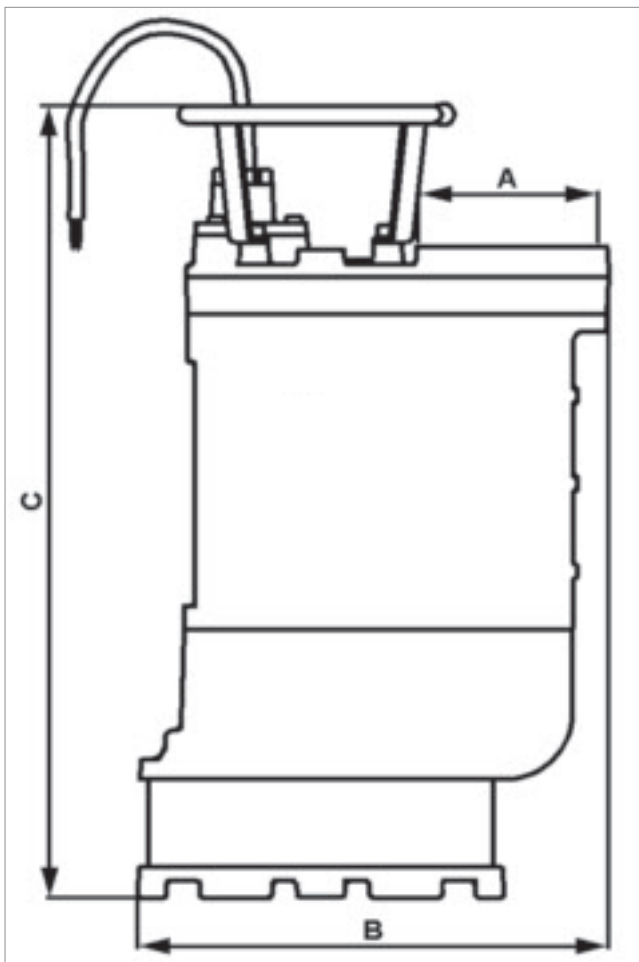

MODELLO / MODEL	DIMENSIONI POMPA in mm. / PUMP DIMENSIONS in mm.		
	A	B	C
TURBO 300	3"	299	542,5
TURBO 400	3"	299	542,5
TURBO 500	3"	299	542,5

MODELLO / MODEL	DIMENSIONI CASSA IN LEGNO / WOODEN CASE				DIMENSIONI PALLET / PALLET DIMENSIONS				
	L	M	N	Peso / Weight	R	S	T	nr.	Peso / Weight
	mm.	mm.	mm.	Kg.	mm.	mm.	mm.	wooden case	Kg.
TURBO 300	715	395	370	60,0	715	790	2200	12	720
TURBO 400	715	395	370	61,0	715	790	2200	12	732
TURBO 500	715	395	370	62,0	715	790	2200	12	744

# TURBO 750-1000



## ELETTROPOMPE SOMMERGIBILI MONOBLOCCO MULTISTADIO VERTICALI IN GHISA VERTICAL SUBMERSIBLE MULTI STAGE ELECTRIC PUMPS IN CAST IRON

**PREVALENZA** ..... : 70 ÷ 80 mt.  
**PORTATA** ..... : 30 m<sup>3</sup>/h  
**POTENZA NOMINALE** : 5,5 kW (7,5 HP) ÷ 7,5 kW (10 HP)

**PUMP HEAD** ..... : 70,0 mt ÷ 80,0 mt  
**DELIVERY**..... : 30,0 m<sup>3</sup>/h  
**RATED HORSEPOWER** : 5,5 kW (7,5 HP) ÷ 7,5 kW (10,0 HP)

### APPLICAZIONI

- PARTICOLARMENTE INDICATE NEL SETTORE AGRICOLO PER IRRIGAZIONE, POMPAGGIO DI ACQUA DA VASCHE O SERBATOI DI PRIMA RACCOLTA, POZZI DA 8 A 10 POLLICI POCO PROFONDI 10-20 MT, BACINI E CORSI D'ACQUA
- MOVIMENTAZIONE NEL SETTORE INDUSTRIALE DI ACQUE DI RAFFREDDAMENTO E DI ALIMENTAZIONE E SCARICO.
- PRESSURIZZAZIONE CON POMPA INSERITA NEL SERBATOIO O POZZO
- FONTANE.

### APPLICATIONS

- PARTICULARLY SUITED TO THE AGRICULTURAL AND FARMING SECTORS FOR IRRIGATION PURPOSES, FOR CATCH TANK AND RESERVOIR CATCH-WATER PUMP OUT, FROM 8 TO 10 INCH WELL, WITH 10-20 MT DEEP, WATER BASIN AND WATER DRAIN FLOW PUMP OUT.
- FOR INDUSTRIAL COOLING, FEED-IN AND DISCHARGE WATER HANDLING.
- FOR PRESSURISATION, WITH TANK OR WELL PUMP INCLUSION.
- FOR FOUNTAINS.

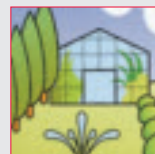
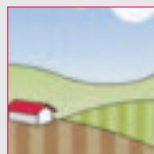
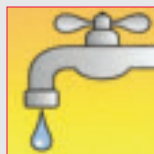

**AV ARVEN**

**CARATTERISTICHE DI COSTRUZIONE**

- MOTORE A BAGNO D'OLIO (BIODEGRADABILE E DIELETTRICO) PER RAFFREDDAMENTO E LUBRIFICAZIONE CUSCINETTI.
- ANELLO DI TENUTA LATO MOTORE
- TENUTA MECCANICA A BAGNO D'OLIO.
- IMMERSIONE MASSIMA: mt. 20.
- GRADO DI PROTEZIONE IP 68.
- CLASSE DI ISOLAMENTO: F.
- TEMPERATURA MAX. LIQUIDO POMPATO: 35°C.
- VERSIONI:  
Trifase: 380-400V/ 50Hz con protezione da sovraccarico a cura dell'utente.
- CAVO STANDARD:  
Trifase: 10 mt H07RN-F senza spina.
- OPZIONI:
- CAVO PIU' LUNGO SU RICHIESTA.
- SPECIALE VOLTAGGIO E FREQUENZE A RICHIESTA.

**ACCESSORI DISPONIBILI A RICHIESTA:**

- QUADRO ELETTRICO TRIFASE DI PROTEZIONE E COMANDO AUTOMATICO A MEZZO GALLEGGIANTE ELETTROMECCANICO.
- GALLEGGIANTE 10-20mt. DI CAVO.
- RACCORDI IN ALLUMINIO.
- RIDUZIONE DA 4" A 3".

**DESIGN ENGINEERING**

- OIL BATH MOTOR (BIODEGRADABLE AND DIELECTRIC) FOR COOLING AND BEARING LUBRICATION.
- SEALING RING - ENGINE FACE.
- OIL BATH MECHANICAL SEALS.
- PERMISSIBLE EIGHT OF WATER: 20 m.
- IP 68 PROTECTION CLASS.
- CLASS "F" INSULATION.
- MAX. PUMPED LIQUID TEMPERATURE: 35°C.
- VERSIONS:  
Three Phases: 380-400V/50Hz with overload protection care of the User.
- STANDARD CABLE FEATURES:  
Three Phases: 10 mt H07RN-F without connection plug.
- OPTIONS:
- CABLE LONGER THAN STANDARD VERSION ON REQUEST.
- CUSTOMIZE VOLTAGE AND FREQUENCY RATING AVAILABLE ON DEMAND.

**ACCESSORIES AVAILABLE ON DEMAND:**

- THREE PHASES ELECTRICAL SAFETY POWER SUPPLY BOX WITH AUTOMATIC ELECTROMECHANICAL FLOATER CONTROLS.
- FLOATER CONTROLS 10-20mt. ELECTRIC CABLE.
- ALUMINIUM CONNECTION PIECES .
- RIDUCTION FROM 4" TO 3".

**TABELLA MATERIALI / MATERIALS TABLE:**

Pos.	Componente / Component	Materiale / Materials
A	Coperchio / Cover	GHISA (G20) / CAST IRON
B	Piattello contatti elettrici / Plate electrical contacts	PLASTICA SPECIALE SPECIAL PLASTIC
C	Carcassa motore / Motor housing	GHISA (G20) / CAST IRON
D	Albero (lato pompa) / Shaft (pump side)	ACCIAIO INOX AISI 316 DIN 1.4401 / STAINLESS STEEL
E	Tenuta meccanica / Mechanical seal	Lato Motore / Motor side ANELLO DI TENUTA NBR NBR SEALING RING
		Lato pompa / Pump side CARBURO DI SILICIO SILICON CARBIDE
G	Flangia inferiore / Upper flange	GHISA (G20) / CAST IRON
H	Girante / Impeller	ACCIAIO INOX AISI 304 DIN 1.4301 / STAINLESS STEEL
I	Diffusore / Diffuser	GHISA (G20) / CAST IRON
L	Piattello / Disk	ACCIAIO / STEEL
M	Griglia / Greed	
N	Piatto / Disk base	GHISA (G20) / CAST IRON

**TURBO 750 - 1000**

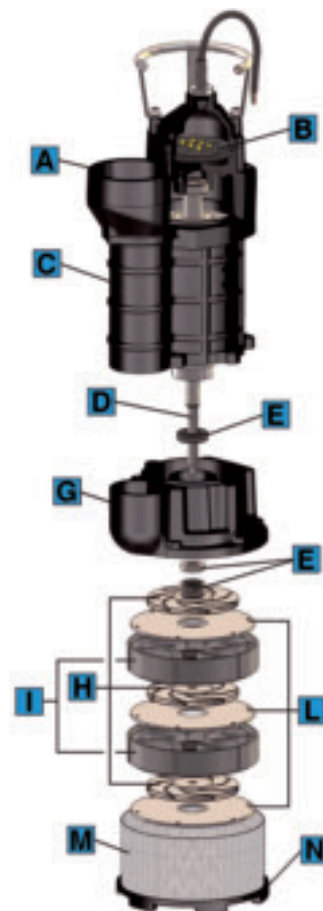

POMPE SOMMERSIBILI IN GHISA  
SUBMERSIBLE PUMPS IN CAST IRON



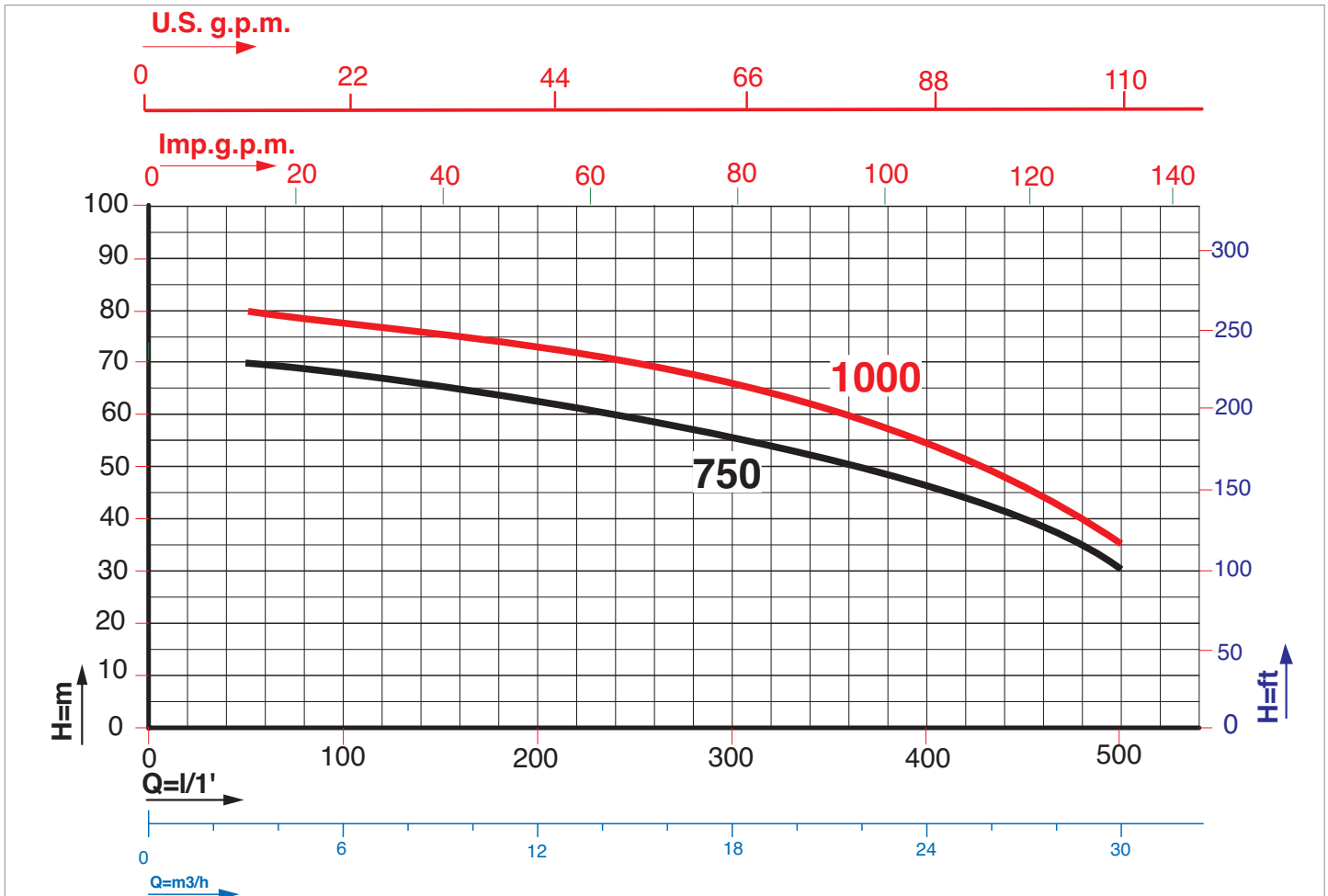

Caratteristiche di funzionamento a 2850 rpm 50Hz - Performances at 2850 rpm 50 Hz

Le prestazioni valgono per liquidi con densità  $\rho = 1,0 \text{ kg/dm}^3$  ed una viscosità  $\nu = 1 \text{ mm}^2/\text{s}$  / The performance data holds true for liquids with a  $\rho = 1,0 \text{ kg/dm}^3$  density and a  $\nu = 1 \text{ mm}^2/\text{s}$  viscosity.

MODELLO MODEL	VOLTAGGIO VOLTAGE 50 Hz	DATI ELETTRICI / ELECTRICAL DATA				DATI IDRAULICI / HYDRAULIC DATA					
		P1max kW	P2 nom. kW	I max HP	Condensatore Capacitor μF VC	m³/h	3	9	15	24	30
TURBO 750 T	3 x 380-400V	7,3	5,5	7,5	12,6	---	---	---	---	---	---
TURBO 1000 T	3 x 380-400V	10,1	7,5	10,0	20,0	---	---	---	---	---	

H (m)	PREVALENZA TOTALE IN METRI COLONNA ACQUA TOTAL PUMP HEAD AND WATER COLUMN HEIGHT IN m.				
	3	9	15	24	30
70,0	65,0	60,0	48,0	30,0	
80,0	75,0	70,0	55,0	35,0	

**DIMENSIONI e PESI / SIZE AND WEIGHT DATA:**

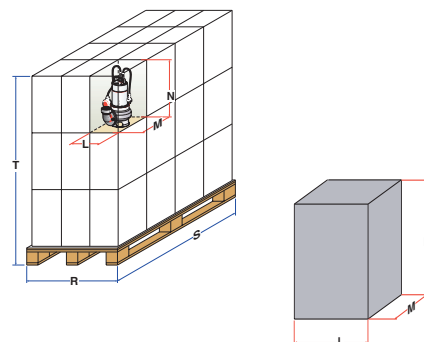
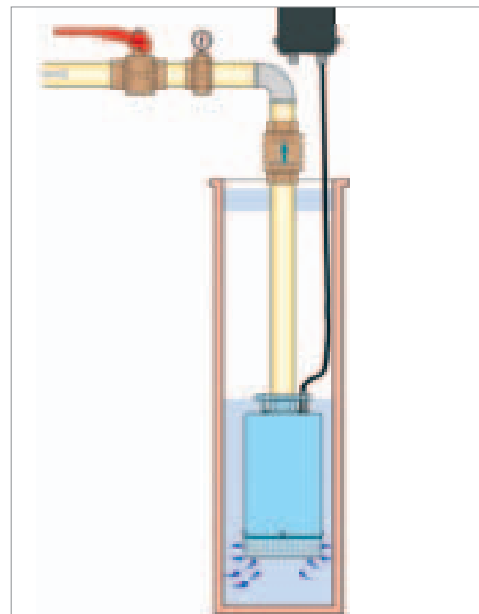
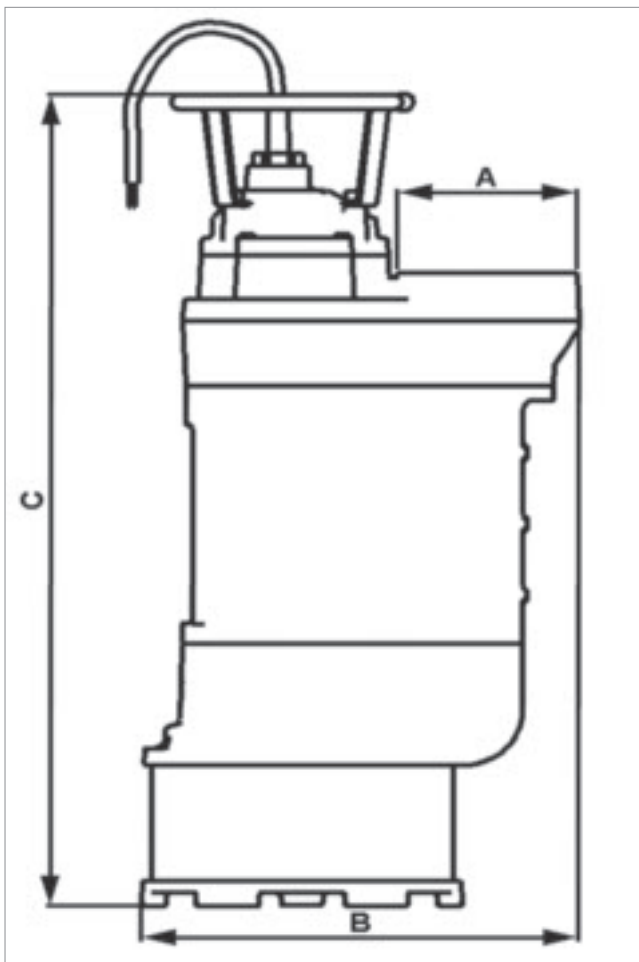

MODELLO / MODEL	DIMENSIONI POMPA in mm. / PUMP DIMENSIONS in mm.		
	A	B	C
TURBO 750	4"	318	645
TURBO 1000	4"	318	645

MODELLO / MODEL	DIMENSIONI CASSE IN LEGNO / WOODEN CASE				DIMENSIONI PALLET / PALLET DIMENSIONS				
	L	M	N	Peso / Weight	R	S	T	nr.	Peso / Weight
	mm.	mm.	mm.	Kg.	mm.	mm.	mm.	wooden case	Kg.
TURBO 750	700	800	330	82,0	700	800	2200	6	515
TURBO 1000	700	800	330	92,0	700	800	2200	6	575

# TURBO L



## ELETTROPOMPE SOMMERSIBILI DRENAGGIO PER ACQUE SPORCHE E LEGGERMENTE SABBIOSE SUBMERSIBLE ELECTRIC PUMPS FOR LIGHTLY SANDY FOUL WASTEWATER DRAINAGE

**PREVALENZA**..... : 18 mt.  
**PORTATA**..... : 24 m<sup>3</sup>/h  
**POTENZA NOMINALE** : 1,5 kW

**PUMP HEAD**..... : 18,0 mt  
**DELIVERY**..... : 24,0 m<sup>3</sup>/h  
**RATED HORSEPOWER** : 1,5 kW

### APPLICAZIONI

- SVUOTAMENTO DI CANTINE, AUTORIMESSE, SCANTINATI
- PARTICOLARMENTE ADATTE PER CANTIERISTICA.
- SVUOTAMENTO DI PISCINE VASCHE IN GENERE E SERBATOI.
- SVUOTAMENTO DA ACQUE PIOVANE, D'INFILTRAZIONE, DI POZZETTI O VASCHE DI RACCOLTA.
- IRRIGAZIONE ORTI E GIARDINI.

### APPLICATIONS

- CELLAR, GARAGE AND BASEMENT PUMP OUT.
- PARTICULARLY SUITED TO CONSTRUCTION WORK SITES
- SWIMMING POOLS, ALL SORTS OF VATS, TANKS AND RESERVOIR PUMP OUT.
- RAIN, SEEPAGE, SUMP PIT AND CATCH TANK WATER PUMP OUT.
- GARDEN AND VEGETABLE-GARDEN IRRIGATION.

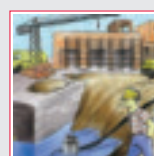
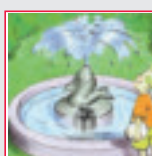
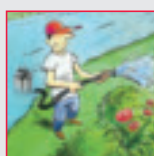

**AV ARVEN**

**CARATTERISTICHE DI COSTRUZIONE**

- MOTORE A BAGNO D'OLIO (BIODEGRADABILE E DIELETTRICO) PE RAFFREDDAMENTO E LUBRIFICAZIONE CUSCINETTI.
- ANELLO DI TENUTA LATO MOTORE
- TENUTA MECCANICA A BAGNO D'OLIO.
- IMMERSIONE MASSIMA: mt. 5.
- GRADO DI PROTEZIONE IP 68.
- CLASSE DI ISOLAMENTO: F.
- TEMPERATURA MAX. LIQUIDO POMPATO: 35°C.
- VERSIONI:  
 Monofase: 220-277V / 50Hz.  
 Trifase: 220-277V/ 50Hz o 380 – 480V /50Hz con protezione da sovraccarico a cura dell'utente.
- VERSIONI MONOFASI AUTOMATICHE CON GALLEGGIANTE.
- CAVO STANDARD:  
 Monofase: H07RN-F 10mt completa di quadro elettrico con spezzone 0,7 metri senza spina.  
 Trifase: H07RN-F 10mt senza spina.

SPECIALI VOLTAGGI E FREQUENZE A RICHIESTA.

**DESIGN ENGINEERING**

- OIL BATH MOTOR (BIODEGRADABLE AND DIELECTRIC) FOR COOLING AND BEARING LUBRICATION.
- SEALING RING - ENGINE FACE.
- OIL BATH MECHANICAL SEALS.
- PERMISSIBLE DRAUGHT OF WATER: 5 m.
- IP 68 PROTECTION CLASS.
- CLASS "F" INSULATION.
- MAX. PUMPED LIQUID TEMPERATURE: 35°C.
- VERSIONS:  
 Single Phase: 220-277V/50Hz.  
 Three Phases: 220-277V/50Hz or 380-480V/50Hz with overload protection care of the User.
- AUTOMATIC SINGLE PHASE VERSIONS up to 1,1 kW.
- STANDARD CABLE FEATURES:  
 Single Phase: H07RN-F 10mt complete with power supply box 0,7 m cable section, without connection plug.  
 Three Phases: H07RN-F 10mt without connection plug.

CUSTOMISED VOLTAGE AND FREQUENCY RATING AVAILABLE ON DEMAND.

**TABELLA MATERIALI / MATERIALS TABLE:**

Pos.	Componente / Component	Materiale / Materials
A	Coperchio / Cover	GHISA (G20) / CAST IRON
B	Guarnizione / Gasket	GOMMA DIELETTRICA DIELECTRIC RUBBER
C	Carcassa motore / Motor housing	GHISA (G20) / CAST IRON
D	Albero (lato pompa) / Shaft (pump side)	ACCIAIO INOX AISI 304 DIN 1.4301 / STAINLESS STEEL
E	Tenuta meccanica / Mechanical seal	Lato Motore / Motor side DOPPIO ANELLO DI TENUTA NBR NBR DOUBLE SEALING RING
		Lato pompa / Pump side CARBURO DI SILICIO/ALLUMINA SILICON CARBIDE-ALUMINA
F	O-ring	NBR
G	Flangia inferiore / Upper flange	GHISA (G20) / CAST IRON
H	Girante / Impeller	
I	Piattello / Disk base	ACCIAIO / STEEL
M	Griglia / Greed	ACCIAIO INOX AISI 304 DIN 1.4301 / STAINLESS STEEL

**TURBO L 200**

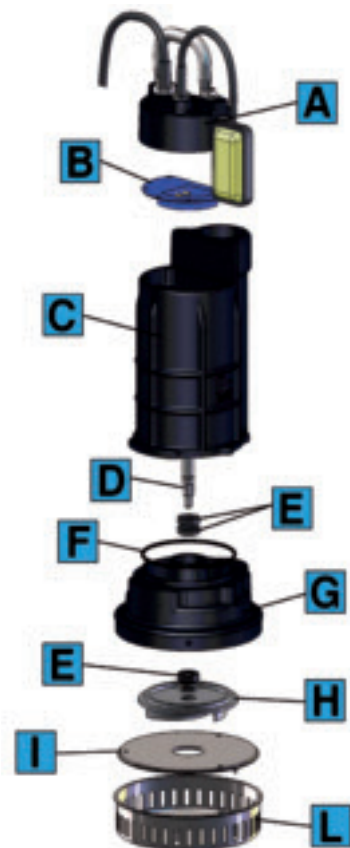

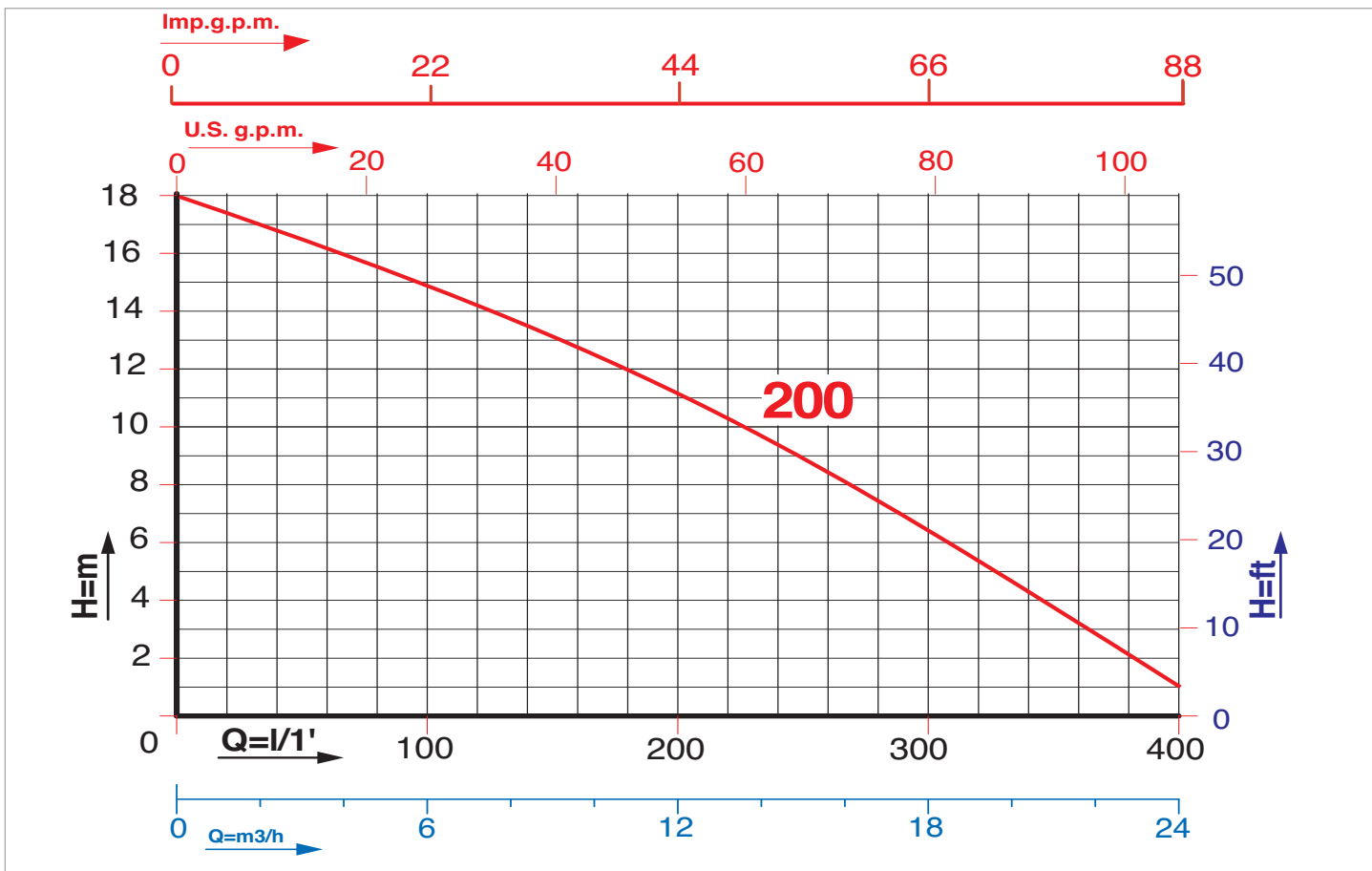

Caratteristiche di funzionamento a 2800 rpm 50Hz - Performances at 2800 rpm 50 Hz

Le prestazioni valgono per liquidi con densità  $\rho = 1,0 \text{ kg/dm}^3$  ed una viscosità  $\nu = 1 \text{ mm}^2/\text{s}$  / The performance data holds true for liquids with a  $\rho = 1,0 \text{ kg/dm}^3$  density and a  $\nu = 1 \text{ mm}^2/\text{s}$  viscosity.

MODELLO MODEL	VOLTAGGIO VOLTAGE 50 Hz	DATI ELETTRICI / ELECTRICAL DATA							DATI IDRAULICI / HYDRAULIC DATA						
		P1 max		P2 nom.		I max	Condensatore Capacitor		m <sup>3</sup> /h		l/min.		H (m)		
		kW	kW	HP	Ampere	$\mu\text{F}$	VC	0	3	6	12	15	18	24	
<b>TURBO L 200 M</b>	1 x 220-230V	2,7	1,5	2,0	12,5	40	450	18,0	16,5	15,0	11,0	9,0	6,5	0,5	
<b>TURBO L 200 T</b>	3 x 380-400V	2,7	1,5	2,0	12,5	---	---	18,0	16,5	15,0	11,0	9,0	6,5	0,5	

PRESSIONE TOTALE IN METRI COLONNA  
 ACQUA  
 TOTAL PUMP HEAD AND WATER COLUMN  
 HEIGHT (m)



**DIMENSIONI e PESI / SIZE AND WEIGHT DATA:**

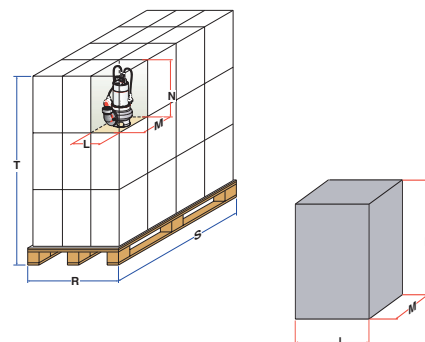
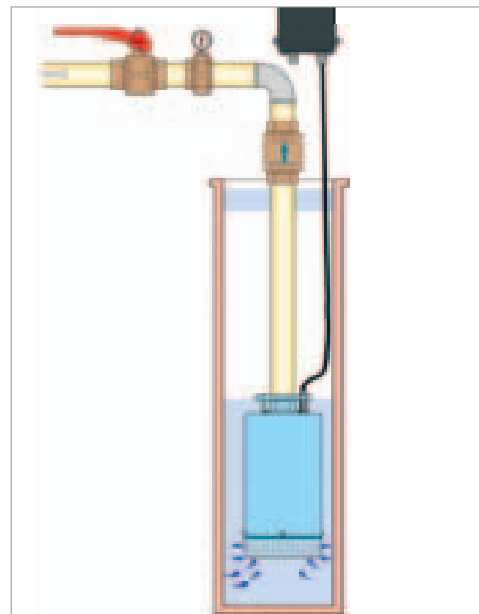
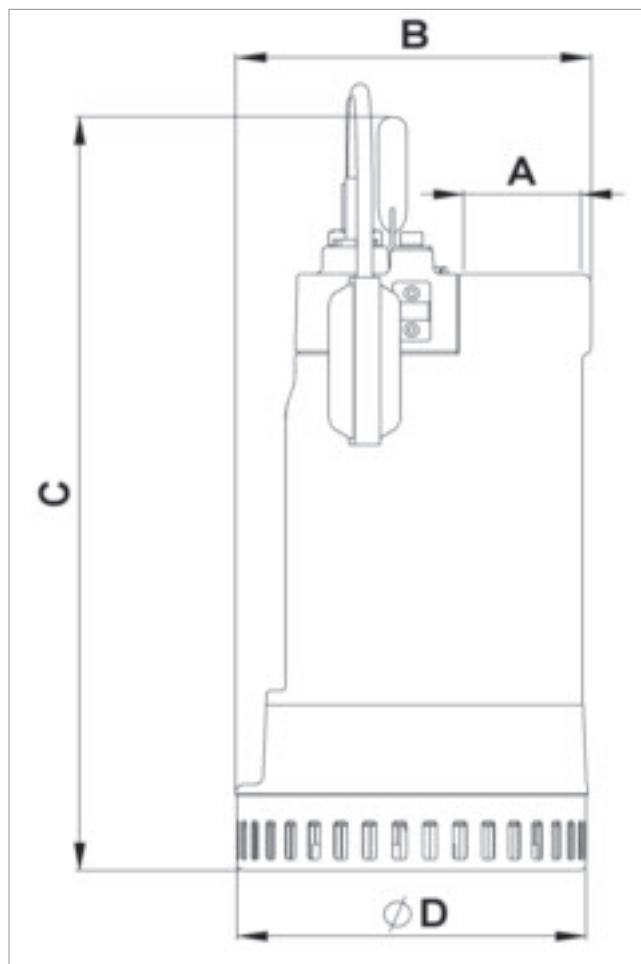

MODELLO / MODEL	DIMENSIONI POMPA in mm. / PUMP DIMENSIONS in mm.			
	A	B	C	D
TURBO L 200	2"	204	472	202

MODELLO / MODEL	DIMENSIONI SCATOLA / PACKING DIMENSIONS				DIMENSIONI PALLET / PALLET DIMENSIONS				
	L	M	N	Peso / Weight	R	S	T	nr.	Peso / Weight
	mm.	mm.	mm.	Kg.	mm.	mm.	mm.	scatole/cartons	Kg.
TURBO L 200	550	260	370	39,0	800	1200	2370	24	965

# TURBO LG 250-350

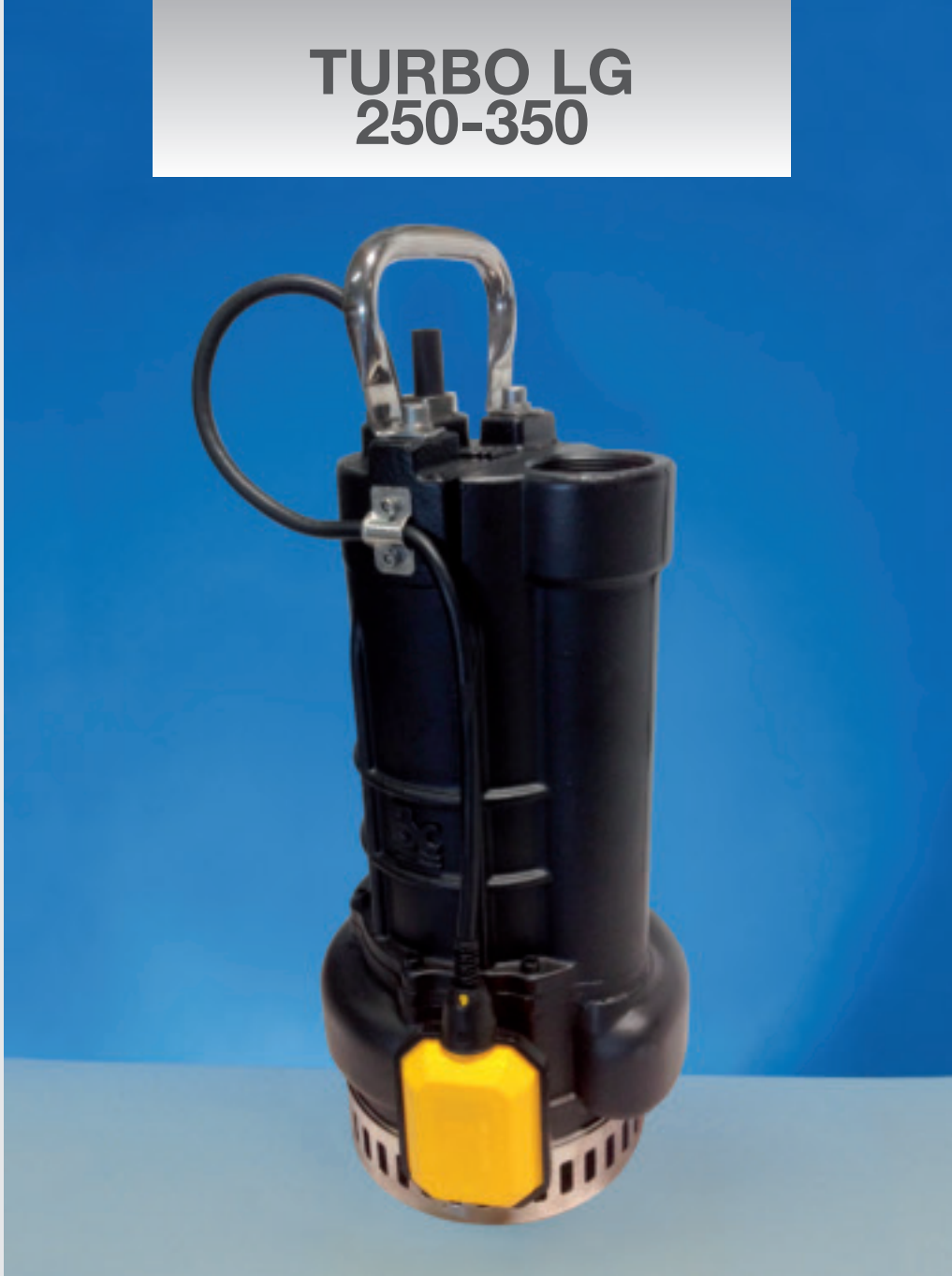

## ELETTROPOMPE SOMMERGIBILI DRENAGGIO PER CANTIERISTICA SUBMERSIBLE ELECTRIC PUMPS FOR COSTRUCTION WORK SITE DRAINAGE

**PREVALENZA** ..... : 19,0 ÷ 23,0 mt.  
**PORTATA** ..... : 27 ÷ 30 m<sup>3</sup>/h  
**POTENZA NOMINALE** .... : 1,8 kW (2,5HP) ÷ 2,6 kW (3,5HP)

**PUMP HEAD** ..... : 19,0 mt ÷ 23,0 mt  
**DELIVERY** ..... : 27,0 m<sup>3</sup>/h ÷ 30,0 m<sup>3</sup>/h  
**RATED HORSEPOWER** .... : 1,8 kW (2,5HP) ÷ 2,6 kW (3,5HP)

### APPLICAZIONI

- DRENAGGIO DI CANTIERI EDILI E DI CUNICOLI.
- MOVIMENTAZIONE DI ACQUE MODERATAMENTE CARICHE CONTENENTI MATERIALI ANCHE ABRASIVI, IMPIANTI DI IRRIGAZIONE, ACQUE PIOVANE E DI FALDA.

### APPLICATIONS

- WORK SITE, TRENCH DUCTS AND UNDERGROUND PASSAGE PUMP OUT
- HANDLING OF MODERATELY FOUL WATER WITH MATERIAL AND/OR ABRASIVE MATERIAL CONTENTS.

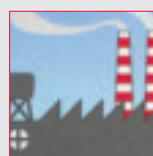
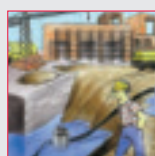
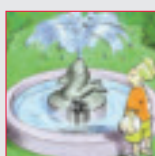

**AV ARVEN**

**CARATTERISTICHE DI COSTRUZIONE**

- MOTORE A BAGNO D'OLIO (BIODEGRADABILE E DIELETTRICO) PER RAFFREDDAMENTO E LUBRIFICAZIONE CUSCINETTI.
- DOPPIA TENUTA MECCANICA: LATO MOTORE A BAGNO D'OLIO, LATO POMPA A BAGNO D'ACQUA.
- IMMERSIONE MASSIMA: mt. 10.
- GRADO DI PROTEZIONE IP 68 .
- CLASSE DI ISOLAMENTO: F.
- TEMPERATURA MAX. LIQUIDO POMPATO: 35°C.
- PASSAGGIO LIBERO: 10mm.
- VERSIONI:  
 Monofase: 220-277V / 50Hz con protettore termico incorporato.  
 Trifase: 380-400V/ 50Hz con protezione da sovraccarico a cura dell'utente.
- CAVO STANDARD:  
 Monofase: H07RN-F 10mt completa di quadro elettrico con spezzone 0,7 metri senza spina.  
 Trifase: H07RN-F 10mt senza spina.

SPECIALE VOLTAGGIO E FREQUENZE A RICHIESTA.

**DESIGN ENGINEERING**

- OIL BATH MOTOR (BIODEGRADABLE AND DIELECTRIC) FOR COOLING AND BEARING LUBRICATION.
- DOUBLE MECHANICAL SEALS: ENGINE FACE: OIL BATH. PUMP FACE: WATER BATH.
- PERMISSIBLE EIGHT OF WATER: 10 m.
- IP 68 PROTECTION CLASS.
- CLASS "F" INSULATION.
- BY PASS SECTION: 10mm.
- MAX. PUMPED LIQUID TEMPERATURE: 35°C.
- VERSIONS:  
 Single Phase: 220-277V/50Hz with built in thermal protection.  
 Three Phases: 380-400V/50Hz with overload protection care of the User.
- STANDARD CABLE FEATURES:  
 Single Phase: H07RN-F 10mt complete with power supply box 0,7 m cable section, without connection plug.  
 Three Phases: H07RN-F 10mt without connection plug.

CUSTOMIZE VOLTAGE AND FREQUENCY RATING AVAILABLE ON DEMAND.

**TABELLA MATERIALI / MATERIALS TABLE:**

Pos.	Componente / Component	Materiale / Materials
A	Coperchio / Cover	GHISA (G20) / CAST IRON
B	Guarnizione / Gasket	GOMMA DIELETTRICA DIELECTRIC RUBBER
C	Carcassa motore / Motor housing	GHISA (G20) / CAST IRON
D	Albero (lato pompa) / Shaft (pump side)	ACCIAIO INOX AISI 304 DIN 1.4301 / STAINLESS STEEL
E	Tenuta meccanica / Mechanical seal	Lato Motore / Motor side DOPPIO ANELLO DI TENUTA NBR NBR DOUBLE SEALING RING
		Lato pompa / Pump side CARBURO DI SILICIO/ALLUMINA SILICON CARBIDE-ALUMINA
F	O-ring	NBR
G	Flangia inferiore / Upper flange G.25	GHISA (GJS400) CAST IRON WITH TREATMENT
H	Girante / Impeller	
I	Diffusore / Diffuser	GHISA (G20) / CAST IRON
L	Griglia / Greed	ACCIAIO INOX AISI 304 DIN 1.4301 / STAINLESS STEEL

**TURBO LG 250-350**

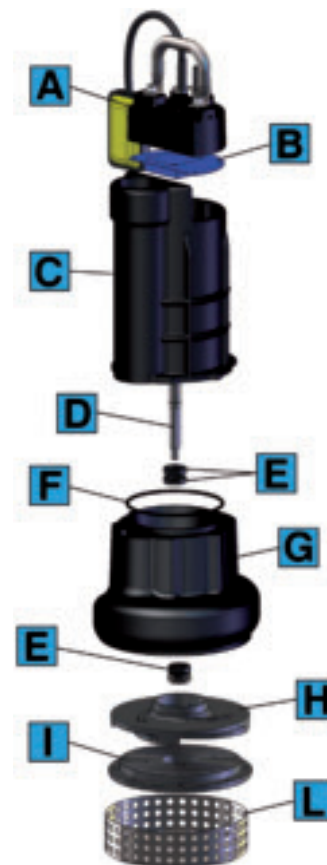

POMPE SOMMERGIBILI IN GHISA  
SUBMERSIBLE PUMPS IN CAST IRON

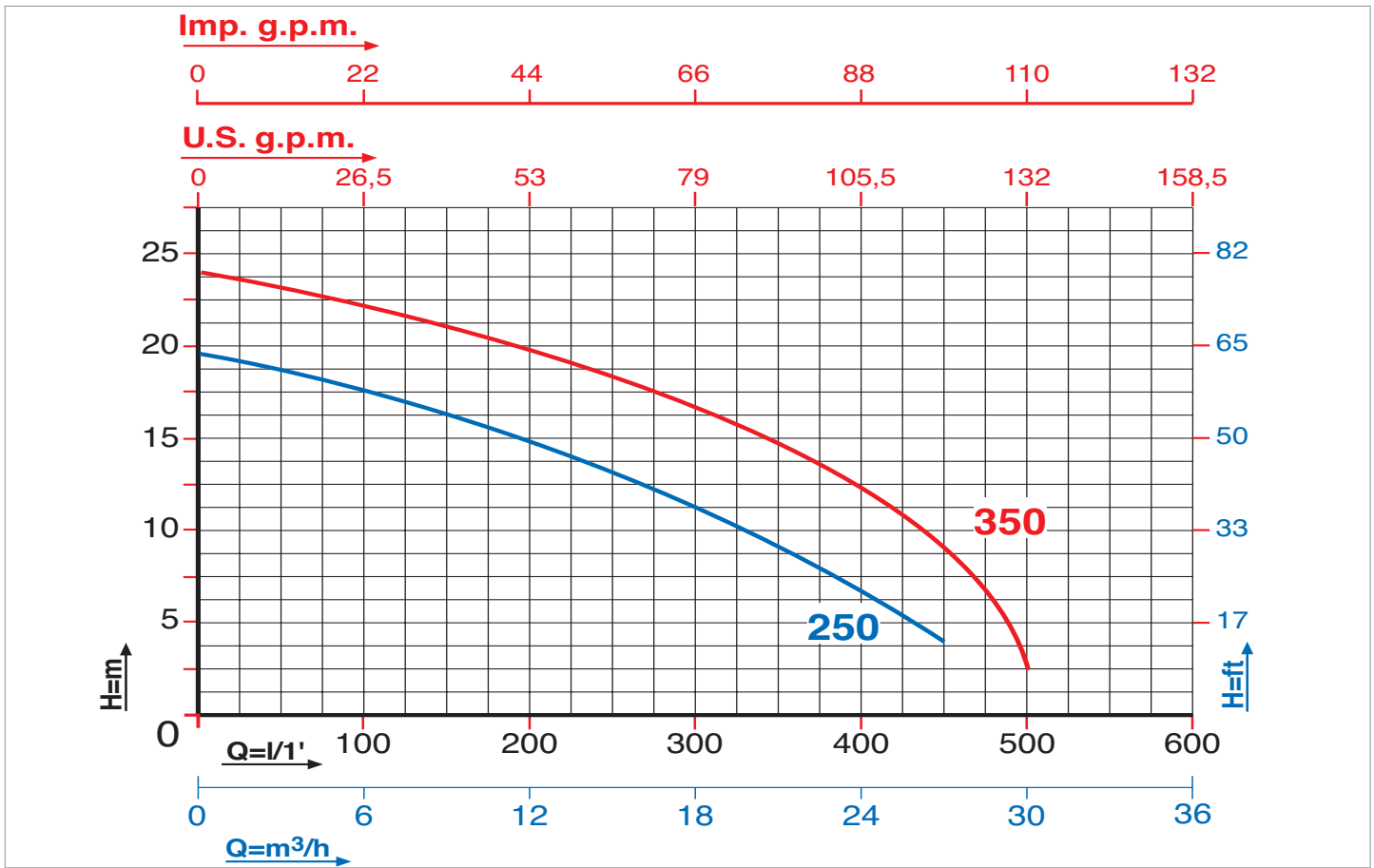

Caratteristiche di funzionamento a 2800 rpm 50Hz - Performances at 2800 rpm 50 Hz

Le prestazioni valgono per liquidi con densità  $\rho = 1,0 \text{ kg/dm}^3$  ed una viscosità  $\nu = 1 \text{ mm}^2/\text{s}$  / The performance data holds true for liquids with a  $\rho = 1,0 \text{ kg/dm}^3$  density and a  $\nu = 1 \text{ mm}^2/\text{s}$  viscosity.

MODELLO MODEL	VOLTAGGIO VOLTAGE 50 Hz	DATI ELETTRICI / ELECTRICAL DATA						DATI IDRAULICI / HYDRAULIC DATA															
		P1 max		P2 nom.		I max	Condensatore Capacitor		m³/h		H (m)												
		kW	kW	HP	Ampere	µF	VC	0	3	6	9	15	18	27	30								
TURBO LG 250 M	1 x 220-230V	3,2	1,8	2,5	13,5	50	450	0	50	100	150	250	300	450	500	19,0	18,5	17,5	16,0	13,0	11,0	3	---
TURBO LG 250 T	3 x 380-400V	3,0	1,8	2,5	4,5	---	---	0	50	100	150	250	300	450	500	19,0	18,5	17,5	16,0	13,0	11,0	3	---
TURBO LG 350 M	1 x 220-230V	4,2	2,6	3,5	16,5	80	450	0	3	6	9	15	18	27	30	24,0	23,0	22,0	21,0	18,0	16,5	6,0	2,5
TURBO LG 350 T	3 x 380-400V	4,0	2,6	3,5	6,0	---	---	0	3	6	9	15	18	27	30	24,0	23,0	22,0	21,0	18,0	16,5	6,0	2,5

PRESSIONE TOTALE IN METRI COLUMNA ACQUA  
TOTAL PUMP HEAD AND WATER COLUMN HEIGHT IN m.

**DIMENSIONI e PESI / SIZE AND WEIGHT DATA:**

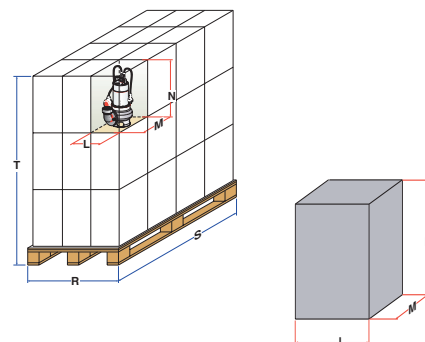
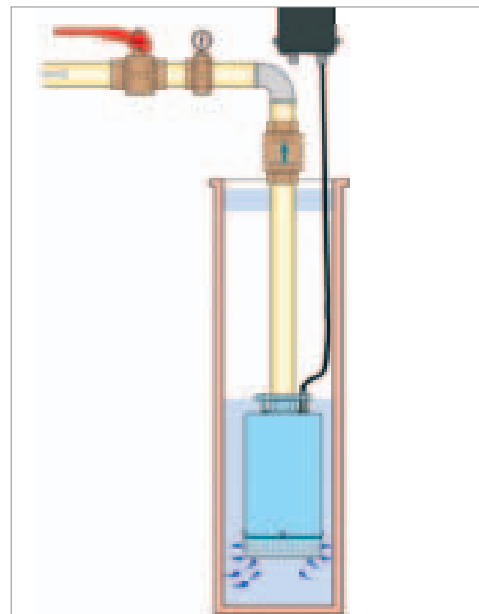
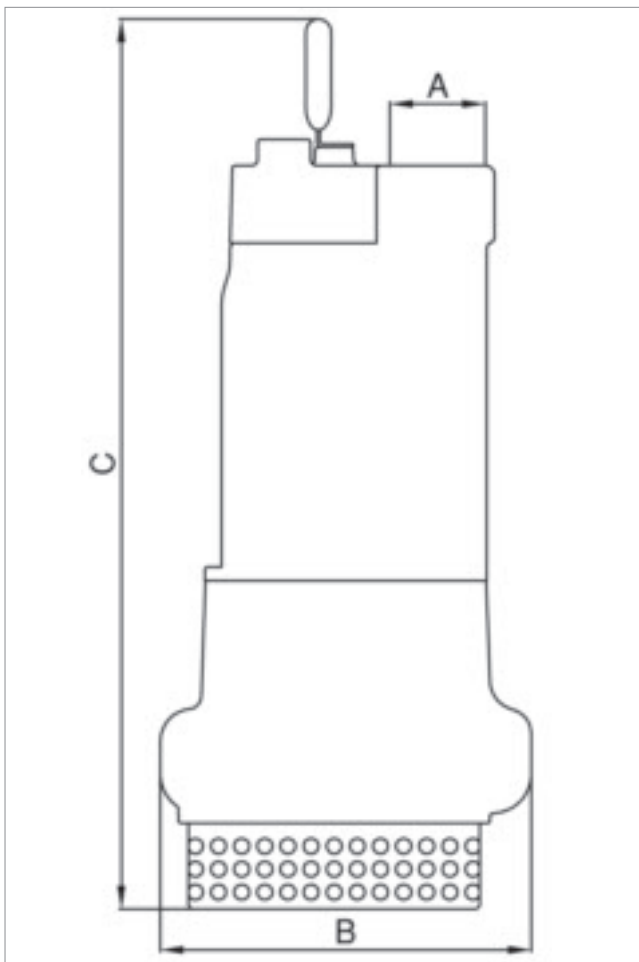

MODELLO / MODEL	DIMENSIONI POMPA in mm. / PUMP DIMENSIONS in mm.		
	A	B	C
TURBO LG 250	2"	240	580
TURBO LG 350	2"	240	580

MODELLO / MODEL	DIMENSIONI SCATOLA / PACKING DIMENSIONS				DIMENSIONI PALLET / PALLET DIMENSIONS				
	L	M	N	Peso / Weight	R	S	T	nr.	Peso / Weight
	mm.	mm.	mm.	Kg.	mm.	mm.	mm.	scatole/cartons	Kg.
TURBO LG 250	600	260	370	45,0	800	1200	2060	28	1280
TURBO LG 350	600	260	370	45,0	800	1200	2060	28	1280



# TURBO LG

## 500-550-750-1000



### ELETTROPOMPE SOMMERGIBILI DRENAGGIO PER CANTIERISTICA SUBMERSIBLE ELECTRIC PUMPS FOR COSTRUCTION WORK SITE DRAINAGE

**PREVALENZA** ..... : 26,0 ÷ 34,0 mt.  
**PORTATA** ..... : 30 ÷ 84 m<sup>3</sup>/h  
**POTENZA NOMINALE** : 3,7 kW (5HP) ÷ 7,5 kW (10HP)

**PUMP HEAD** ..... : 26,0 mt ÷ 34,0 mt  
**DELIVERY** ..... : 30,0 m<sup>3</sup>/h ÷ 84,0 m<sup>3</sup>/h  
**RATED HORSEPOWER** : 3,7 kW (5,0HP) ÷ 7,5 kW (10,0HP)

#### APPLICAZIONI

- DRENAGGIO DI CANTIERI EDILI E DI CUNICOLI.
- MOVIMENTAZIONE DI ACQUE MODERATAMENTE CARICHE CONTENENTI MATERIALI ANCHE ABRASIVI, IMPIANTI DI IRRIGAZIONE, ACQUE PIOVANE E DI FALDA.

#### APPLICATIONS

- WORK SITE, TRENCH DUCTS AND UNDERGROUND PASSAGE PUMP OUT
- HANDLING OF MODERATELY FOUL WATER WITH MATERIAL AND/OR ABRASIVE MATERIAL CONTENTS.

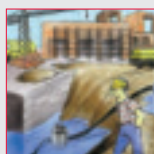
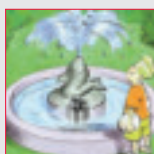

**AV ARVEN**

**CARATTERISTICHE DI COSTRUZIONE**

- MOTORE A BAGNO D'OLIO (BIODEGRADABILE E DIELETTRICO) PER RAFFREDDAMENTO E LUBRIFICAZIONE CUSCINETTI.
- DOPPIA TENUTA MECCANICA: LATO MOTORE A BAGNO D'OLIO, LATO POMPA A BAGNO D'ACQUA.
- IMMERSIONE MASSIMA: mt. 10.
- GRADO DI PROTEZIONE IP 68 .
- CLASSE DI ISOLAMENTO: F.
- TEMPERATURA MAX. LIQUIDO POMPATO: 35°C.
- PASSAGGIO LIBERO: 10mm.
- VERSIONI:  
Trifase: 380-400V/ 50Hz con protezione da sovraccarico a cura dell'utente.
- CAVO STANDARD:  
Trifase: 10 mt H07RN-F senza spina.

SPECIALE VOLTAGGIO E FREQUENZE A RICHIESTA.

**ACCESSORI DISPONIBILI A RICHIESTA:**

- QUADRO ELETTRICO TRIFASE DI PROTEZIONE E COMANDO AUTOMATICO A MEZZO GALLEGGIANTE ELETTROMECCANICO.
- GALLEGGIANTE 10-20mt. DI CAVO.
- RACCORDI IN ALLUMINIO.
- RIDUZIONE DA 4" A 3" (TURBO-LG 1000 T).

**DESIGN ENGINEERING**

- OIL BATH MOTOR (BIODEGRADABLE AND DIELECTRIC) FOR COOLING AND BEARING LUBRICATION.
- DOUBLE MECHANICAL SEALS: ENGINE FACE: OIL BATH, PUMP FACE: WATER BATH.
- PERMISSIBLE EIGHT OF WATER: 10 m.
- IP 68 PROTECTION CLASS.
- CLASS "F" INSULATION.
- BY PASS SECTION: 10mm.
- MAX. PUMPED LIQUID TEMPERATURE: 35°C.
- VERSIONS:  
Three Phases: 380-400V/50Hz with overload protection care of the User.
- STANDARD CABLE FEATURES:  
Three Phases: 10 mt H07RN-F without connection plug.

CUSTOMIZE VOLTAGE AND FREQUENCY RATING AVAILABLE ON DEMAND.

**ACCESSORIES AVAILABLE ON DEMAND:**

- THREE PHASES ELECTRICAL SAFETY POWER SUPPLY BOX WITH AUTOMATIC ELECTROMECHANICAL FLOATER CONTROLS.
- FLOATER CONTROLS 10-20mt. ELECTRIC CABLE.
- ALUMINIUM CONNECTION PIECES.
- RIDUCTION FROM 4" TO 3" (TURBO-LG 1000 T).

**TABELLA MATERIALI / MATERIALS TABLE:**

Pos.	Componente / Component	Materiale / Materials
A	Coperchio / Cover	GHISA (G20) / CAST IRON
B	Guarnizione / Gasket	TURBO-LG 500-550-750 GOMMA DIELETTRICA DIELECTRIC RUBBER
		TURBO-LG 1000 PLASTICA SPECIALE SPECIAL PLASTIC
C	Carcassa motore / Motor housing	GHISA (G20) / CAST IRON
D	Albero (lato pompa) / Shaft (pump side)	ACCIAIO INOX AISI 316 DIN 1.4401 / STAINLESS STEEL
E	Tenuta meccanica Mechanical seal	Lato Motore / Motor side CARBONE-ALLUMINA COAL - ALUMINA
		Lato pompa / Pump side CARBURO DI SILICIO SILICON CARBIDE
F	Flangia inferiore / Upper flange	GHISA (G25) / CAST IRON (G.25)
G	Girante / Impeller	GHISA (GJS400) CAST IRON (GJS400) WITH TREATMENT
H	Diffusore / Diffuser	
I	Griglia / Greed	ACCIAIO / STEEL
L	Piatto / Disk base	
M	Prolunga / Extension	GHISA (G20) / CAST IRON

**TURBO LG 500-550-750**

**TURBO LG 1000**

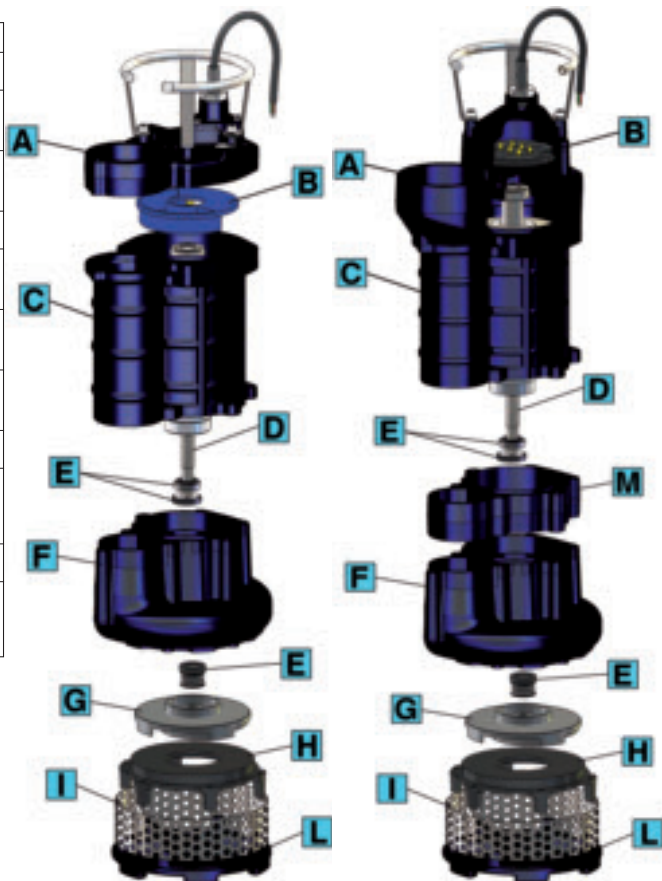

POMPE SOMMERGIBILI IN GHISA  
SUBMERSIBLE PUMPS IN CAST IRON

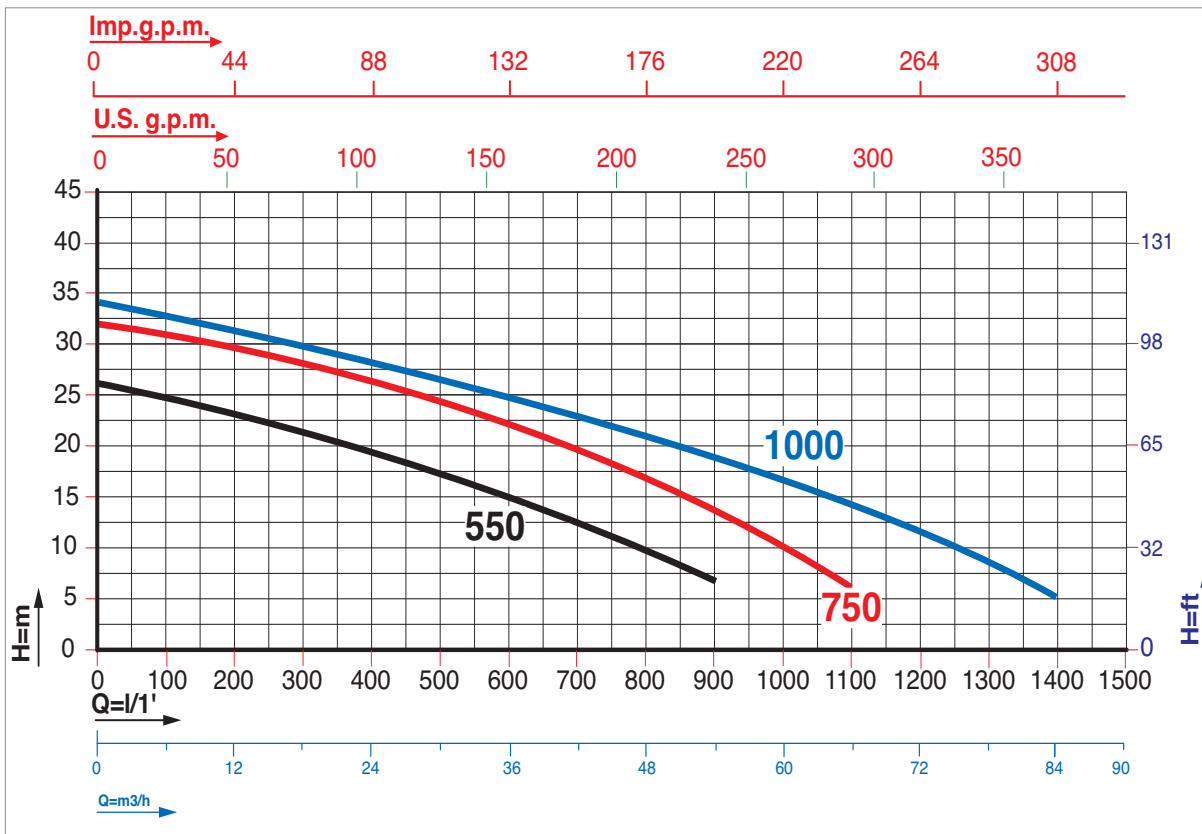
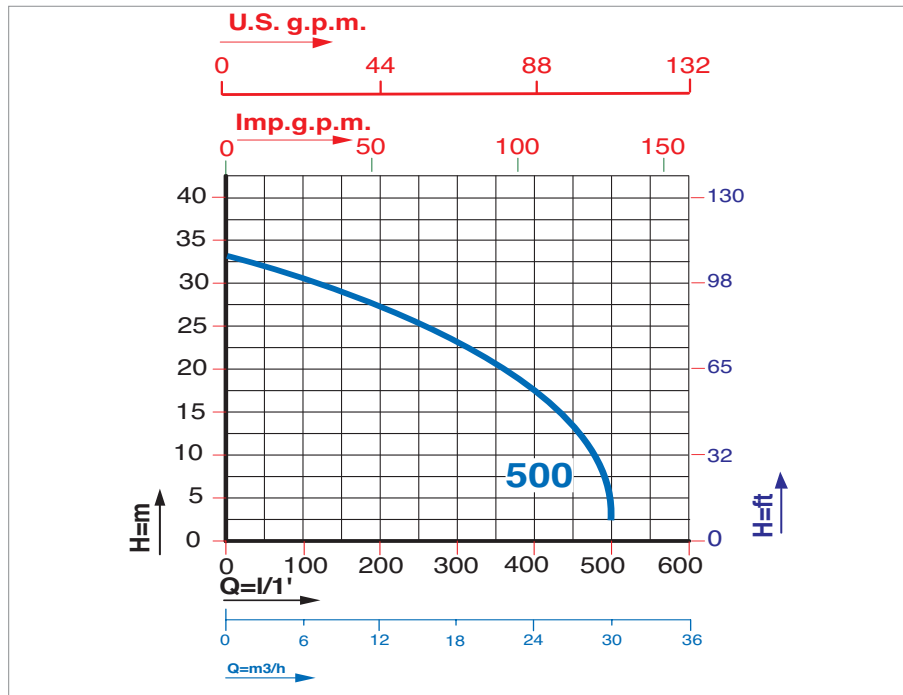

Caratteristiche di funzionamento a 2850 rpm 50Hz - Performances at 2850 rpm 50 Hz

Le prestazioni valgono per liquidi con densità  $\rho = 1,0 \text{ kg/dm}^3$  ed una viscosità  $\nu = 1 \text{ mm}^2/\text{s}$  / The performance data holds true for liquids with a  $\rho = 1,0 \text{ kg/dm}^3$  density and a  $\nu = 1 \text{ mm}^2/\text{s}$  viscosity.

MODELLO MODEL	VOLTAGGIO VOLTAGE 50 Hz	DATI ELETTRICI / ELECTRICAL DATA					DATI IDRAULICI / HYDRAULIC DATA								
		P1 max kW	P2 nom. kW	HP	I max Ampere	Condensatore Capacitor $\mu\text{F}$ VC	m³/h		0	6	18	30	54	66	84
							l/min.		0	100	300	500	900	1100	1400
TURBO LG 500 T	3 x 380-400V	5,5	3,7	5,0	9,5	---	450	H (m)	33,0	30,0	23,0	2,5	---	---	---
TURBO LG 550 T	3 x 380-400V	5,5	3,7	5,0	9,5	---	---		26,0	24,5	21,5	18,0	7,0	---	---
TURBO LG 750 T	3 x 380-400V	7,5	5,5	7,5	11,5	---	450		32,0	31,0	27,5	24,5	13,5	6,0	---
TURBO LG 1000 T	3 x 380-400V	7,5	7,5	10,0	12,5	---	---		34,0	32,5	29,5	27,0	18,5	14,5	5,0

PRESSIONE TOTALE IN METRI COLONNA ACQUA  
TOTAL PUMP HEAD AND WATER COLUMN HEIGHT (m)

**DIMENSIONI e PESI / SIZE AND WEIGHT DATA:**

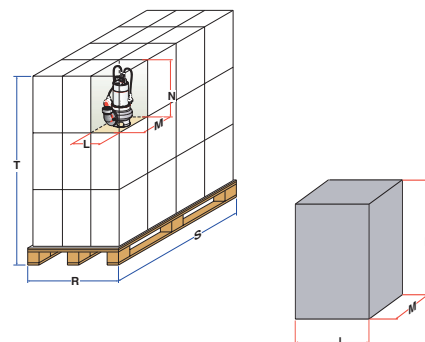
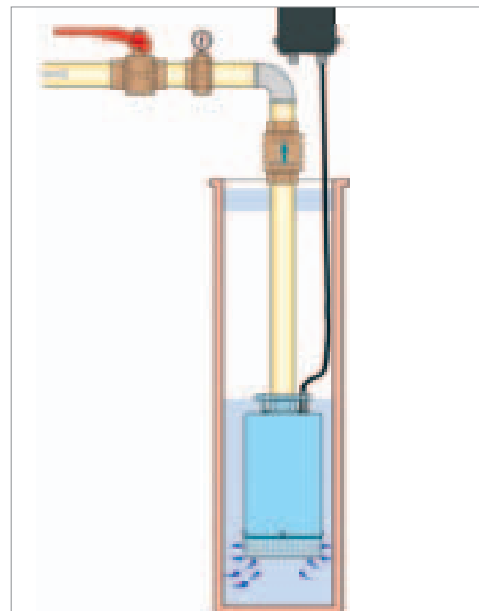
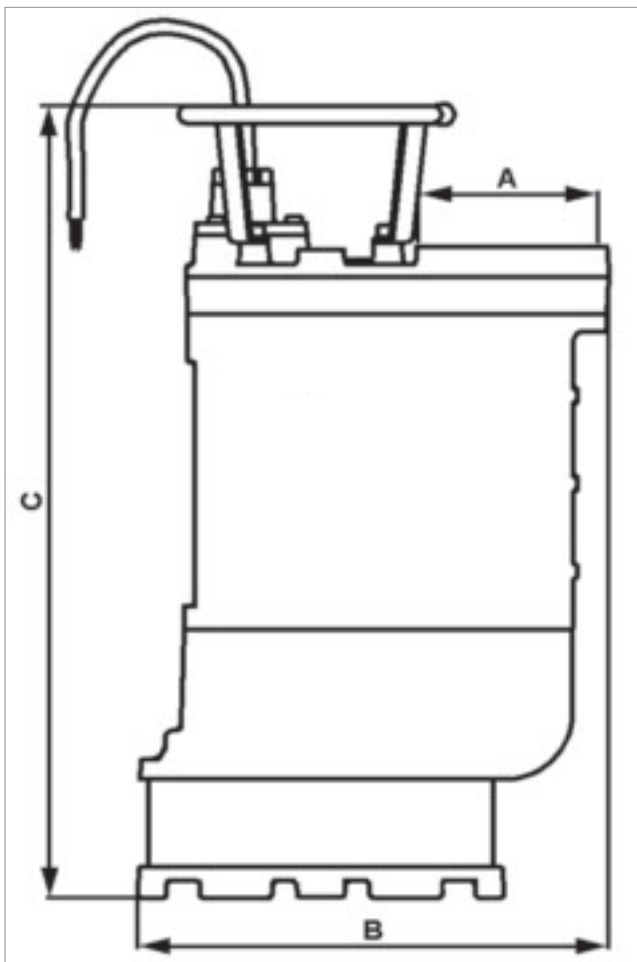

MODELLO / MODEL	DIMENSIONI POMPA in mm. / PUMP DIMENSIONS in mm.		
	A	B	C
TURBO-LG 500	3"	299	542,5
TURBO-LG 550	3"	299	542,5
TURBO-LG 750	3"	299	542,5
TURBO-LG 1000	4"	337	706

MODELLO / MODEL	DIMENSIONI CASSA IN LEGNO / WOODEN CASE				DIMENSIONI PALLET / PALLET DIMENSIONS				
	L	M	N	Peso / Weight	R	S	T	nr.	Peso / Weight
	mm.	mm.	mm.	Kg.	mm.	mm.	mm.	wooden case	Kg.
TURBO-LG 500	715	395	370	60,0	715	790	2200	12	740
TURBO-LG 550	715	395	370	60,0	715	790	2200	12	740
TURBO-LG 750	715	395	370	62,0	715	790	2200	12	764
TURBO-LG 1000	700	800	330	90,0	700	800	2200	6	560

# TURBO TC 200-300



## ELETTROPOMPE SOMMERSIBILI BICANALI PER ACQUE CARICHE SUBMERSIBLE TWIN-CHANNEL ELECTRIC PUMPS FOR WASTEWATER

**PREVALENZA** ..... : 16,0 ÷ 19,0 mt.  
**PORTATA** ..... : 30 ÷ 39 m<sup>3</sup>/h  
**POTENZA NOMINALE** : 1,5 kW (2,0HP) ÷ 2,25 kW (3,0HP)

**PUMP HEAD** ..... : 16,0 mt ÷ 19,0 mt  
**DELIVERY** ..... : 30,0 m<sup>3</sup>/h ÷ 39,0 m<sup>3</sup>/h  
**RATED HORSEPOWER** : 1,5 kW (2,0HP) ÷ 2,25 kW (3,0HP)

### APPLICAZIONI

- SVUOTAMENTO DI FOSSE DI DECANTAZIONE, POZZI NERI, POZZI DI RACCOLTA LIQUAMI
- POMPAGGIO DI ACQUE LURIDE ANCHE CON CORPI SOLIDI IN SOSPENSIONE
- MOVIMENTAZIONE DI ACQUE LURIDE AD USO DOMESTICO ED INDUSTRIALE

### APPLICATIONS

- DECANTATION PIT, SEWAGE PIT AND SLURRY COLLECTION PIT PUMP OUT
- PUMP OUT OF LAVATORY/FOUL WATER WITH POSSIBLE FLOATING SOLIDS CONTENTS
- DOMESTIC AND INDUSTRIAL LAVATORY/BLACK WATER HANDLING SYSTEMS.

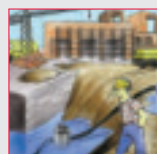
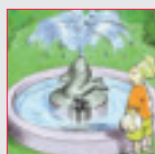

**AV ARVEN**



**CARATTERISTICHE DI COSTRUZIONE**

- MOTORE A BAGNO D'OLIO (BIODEGRADABILE E DIELETTRICO) PER RAFFREDDAMENTO E LUBRIFICAZIONE CUSCINETTI.
- DOPPIA TENUTA MECCANICA: LATO MOTORE A BAGNO D'OLIO, LATO POMPA A BAGNO D'ACQUA.
- IMMERSIONE MASSIMA: mt. 10.
- GRADO DI PROTEZIONE IP 68 .
- CLASSE DI ISOLAMENTO: F.
- TEMPERATURA MAX. LIQUIDO POMPATO: 35°C.
- PASSAGGIO LIBERO: 25mm.
- VERSIONI:  
Trifase: 380-400V/ 50Hz con protezione da sovraccarico a cura dell'utente.
- CAVO STANDARD:  
Trifase: 10 mt H07RN-F senza spina.

SPECIALE VOLTAGGIO E FREQUENZE A RICHIESTA.

**DESIGN ENGINEERING**

- OIL BATH MOTOR (BIODEGRADABLE AND DIELECTRIC) FOR COOLING AND BEARING LUBRICATION.
- DOUBLE MECHANICAL SEALS: ENGINE FACE: OIL BATH. PUMP FACE: WATER BATH.
- PERMISSIBLE EIGHT OF WATER: 10 m.
- IP 68 PROTECTION CLASS.
- CLASS "F" INSULATION.
- MAX. PUMPED LIQUID TEMPERATURE: 35°C.
- BY PASS SECTION: 25mm.
- VERSIONS:  
Three Phases: 380-400V/50Hz with overload protection care of the User.
- STANDARD CABLE FEATURES:  
Three Phases: 10 mt H07RN-F without connection plug.

CUSTOMIZE VOLTAGE AND FREQUENCY RATING AVAILABLE ON DEMAND.

**TABELLA MATERIALI / MATERIALS TABLE:**

Pos.	Componente / Component	Materiale / Materials
A	Coperchio / Cover	GHISA (G20) / CAST IRON
B	Guarnizione / Gasket	GOMMA / RUBBER NBR 70
C	Carcassa motore / Motor housing	GHISA (G20) / CAST IRON
D	Albero / Shaft	ACCIAIO INOX AISI 416 DIN 1.4005 / STAINLESS STEEL
E	Tenuta meccanica / Mechanical seal	Lato Motore / Motor side DOPPIO ANELLO DI TENUTA NBR NBR DOUBLE SEALING RING
		Lato pompa / Pump side CARBURO DI SILICIO/ALLUMINA SILICON CARBIDE-ALUMINA
F	O-ring	NBR
G	Flangia inferiore / Upper flange	GHISA (G25) / CAST IRON
H	Girante / Impeller	GHISA (G20) / CAST IRON
I	Diffusore / Diffuser	
L	Piattello / Disk base	ACCIAIO INOX AISI 304 DIN 1.4301 / STAINLESS STEEL

**TURBO TC 200-300**

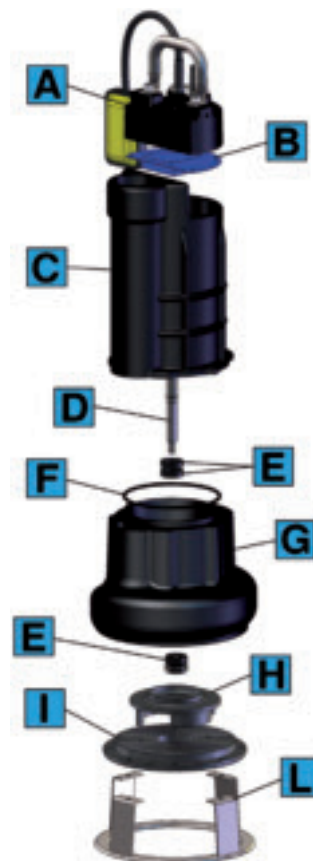

POMPE SOMMERGIBILI IN GHISA  
SUBMERSIBLE PUMPS IN CAST IRON



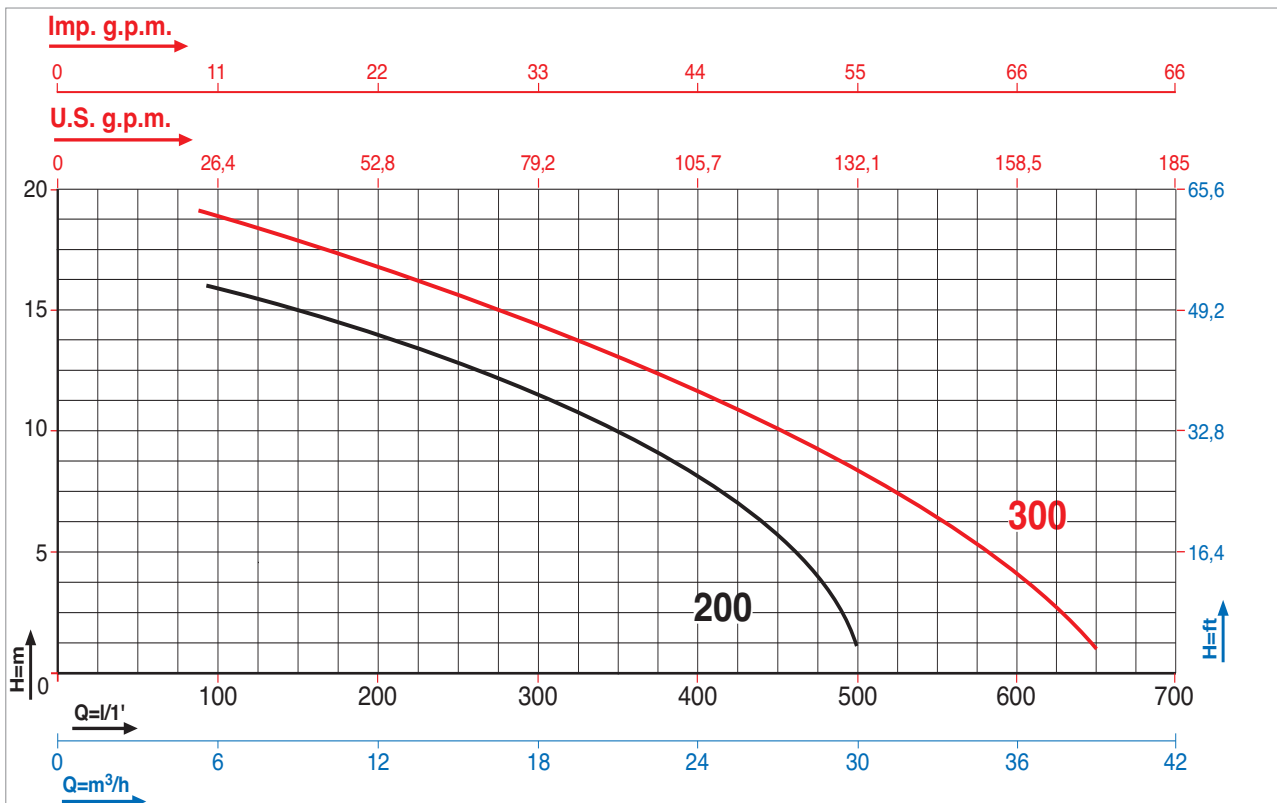

Caratteristiche di funzionamento a 2850 rpm 50Hz - Performances at 2850 rpm 50 Hz

Le prestazioni valgono per liquidi con densità  $\rho = 1,0 \text{ kg/dm}^3$  ed una viscosità  $\nu = 1 \text{ mm}^2/\text{s}$  / The performance data holds true for liquids with a  $\rho = 1,0 \text{ kg/dm}^3$  density and a  $\nu = 1 \text{ mm}^2/\text{s}$  viscosity.

MODELLO MODEL	VOLTAGGIO VOLTAGE 50 Hz	DATI ELETTRICI / ELECTRICAL DATA					DATI IDRAULICI / HYDRAULIC DATA								
		P1max kW	P2 nom. kW	HP	I max Ampere	Condensatore Capacitor $\mu\text{F}$ VC	m³/h l/min.	6	9	15	18	24	27	30	39
TURBO TC 200 M	1 x 220-230V	2,5	1,5	2,0	13,0	40	450	16,0	15,0	12,5	11,0	8,0	5,5	1,0	---
TURBO TC 200 T	3 x 380-400V	2,3	1,5	2,0	4,0	---	---	16,0	15,0	12,5	11,0	8,0	5,5	1,0	---
TURBO TC 300 M	1 x 220-230V	3,5	2,25	3,0	15,0	50	450	19,0	17,5	15,5	14,5	11,5	10,0	8,0	1,0
TURBO TC 300 T	3 x 380-400V	3,3	2,25	3,0	6,0	---	---	19,0	17,5	15,5	14,5	11,5	10,0	8,0	1,0

PRESSIONE TOTALE IN METRI COLUMNA ACQUA  
TOTAL PUMP HEAD AND WATER COLUMN HEIGHT IN m.

**DIMENSIONI e PESI / SIZE AND WEIGHT DATA:**

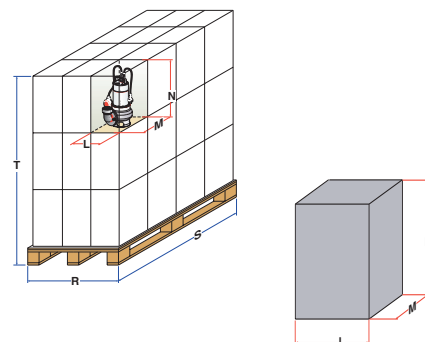
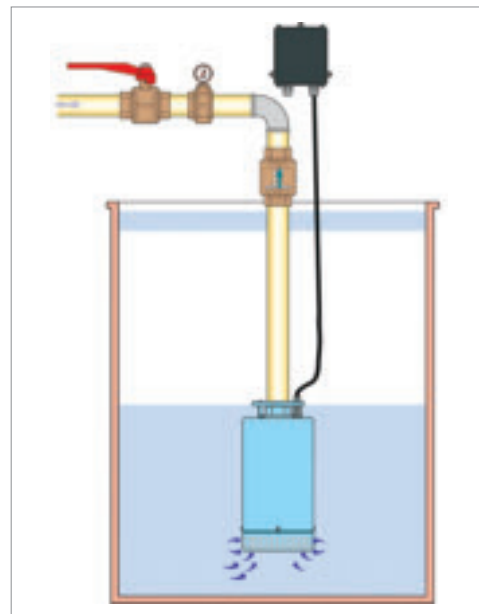
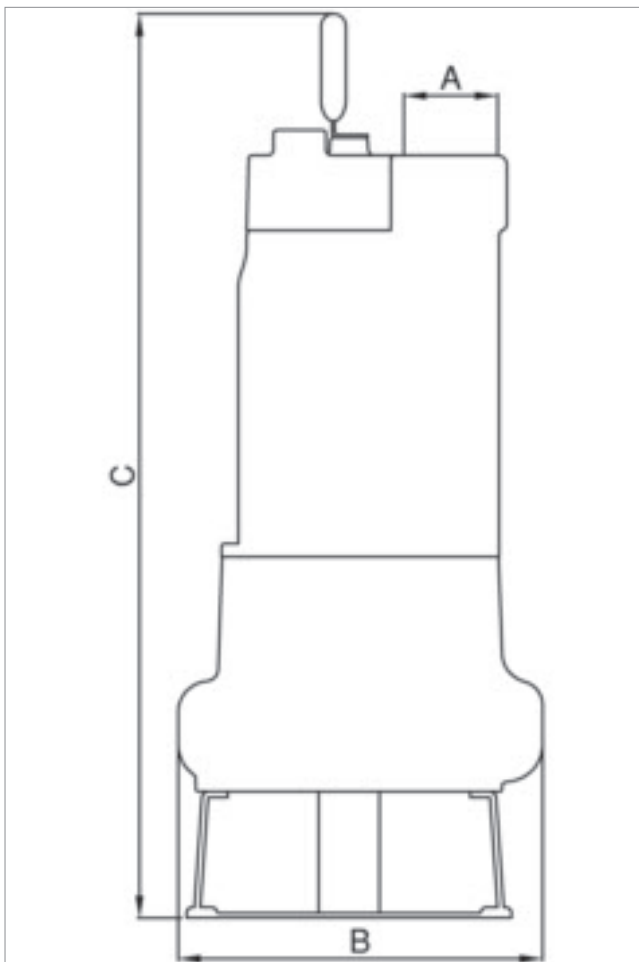

MODELLO / MODEL	DIMENSIONI POMPA in mm. / PUMP DIMENSIONS in mm.		
	A	B	C
TURBO TC 200	2"	240	618
TURBO TC 300	2"	240	618

MODELLO / MODEL	DIMENSIONI SCATOLA / PACKING DIMENSIONS				DIMENSIONI PALLET / PALLET DIMENSIONS				
	L	M	N	Peso / Weight	R	S	T	nr.	Peso / Weight
	mm.	mm.	mm.	Kg.	mm.	mm.	mm.	scatole/cartons	Kg.
TURBO TC 200	640	260	370	45,0	800	1200	2060	21	960
TURBO TC 300	640	260	370	45,0	800	1200	2060	21	960

# NCC 24

## ELETTROPOMPE A 24 VOLT 24 VOLT ELECTROPUMPS



### APPLICAZIONI

- PER PISCINE
- SVUOTAMENTO NATANTI

### APPLICATIONS

- FOR SWIMMING POOL
- FOR EMPTYING BOAT

### CARATTERISTICHE COSTRUTTIVE

Corpo pompa: PP30V  
Classe di isolamento: F  
Classe di protezione: IP 68  
Girante: NORYL

### MAIN FACTURES

Pump body: PP30V  
Insulation class: F  
Protection class: IP68  
Impeller: NORYL

### DRENAGGIO / DRAINAGE

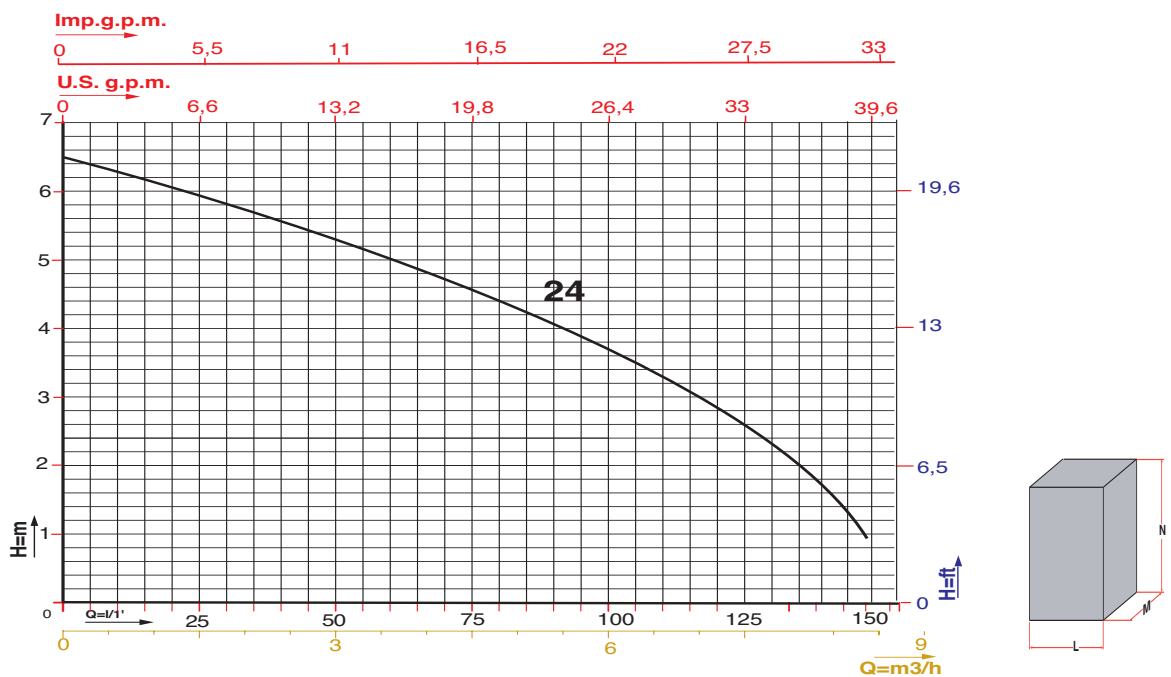

TYPE	HP (P2)	kW (P1)	VOLT	AMP
NCC 24	0,37	0,3	24V - DC	13

Q l/min	0	20	50	100	150
Q m3/h	0	1,2	3	6	9
H/m	6,5	5,8	4,9	3,0	0,9

TYPE	L	N	M	KG	Q.TY EURO PALLET
NCC 24	220	370	170	5,2	100



# NCC 24 T

## ELETTROPOMPE A 24 VOLT 24 VOLT ELECTROPUMPS



### APPLICAZIONI

- PER PISCINE
- SVUOTAMENTO NATANTI

### APPLICATIONS

- FOR SWIMMING POOL
- FOR EMPTYING BOAT

### CARATTERISTICHE COSTRUTTIVE

Corpo pompa: PP30V  
Classe di isolamento: F  
Classe di protezione: IP 68  
Girante: NORYL

### MAIN FACTURES

Pump body: PP30V  
Insulation class: F  
Protection class: IP68  
Impeller: NORYL

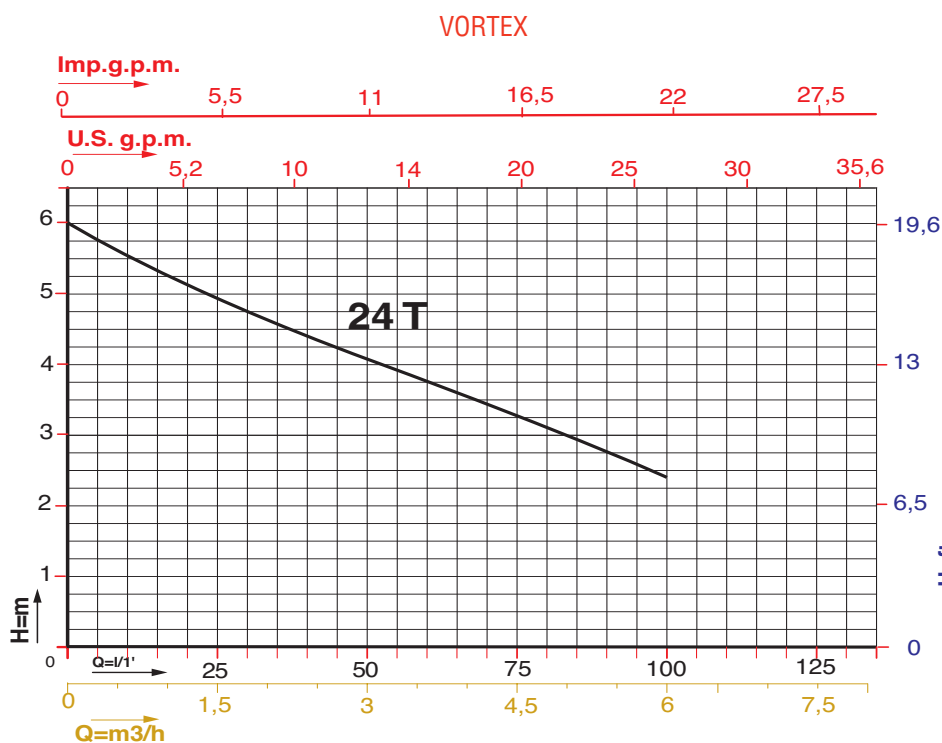

TYPE	HP (P2)	kW (P1)	VOLT	AMP
NCC 24 T	0,48	0,38	24V - DC	17

Q l/min	0	20	50	100	150
Q m3/h	0	1,2	3	6	9
H/m	6,0	5,0	4,2	2,5	---

TYPE	L	N	M	KG	Q.TY EURO PALLET
NCC 24 T	220	370	170	6,7	100



# SPA

## ELETTROPOMPE SOMMERGIBILI IN PLASTICA DRENAGGIO PER ACQUE CHIARE PLASTIC SUBMERSIBLE PUMPS FOR WHITE WATER DRAINAGE



### APPLICAZIONI

- SVUOTAMENTO DA ACQUE PIOVANE D'INFILTRAZIONE, DI POZZETTI O VASCHE DI RACCOLTA
- PRELIEVO DA VASCHE DI RACCOLTA DI ACQUE PIOVANE PER PICCOLE IRRIGAZIONI A SCORRIMENTO DI ORTI E GIARDINI.
- TRAVASO DI ACQUA CHIARA DA SERBATOI E VASCHE

### APPLICATIONS

- RAIN, SEEPAGE, SUMP PIT AND CATCH TANK WATER PUMP OUT
- GARDEN AND VEGETABLE GARDEN MINI FLOOD IRRIGATION SYSTEM RAIN WATER CATCH TANK PUMP DOWN
- WHITE WATER PUMP OVER FROM RESERVOIRS AND VATS

### DRENAGGIO / DRAINAGE

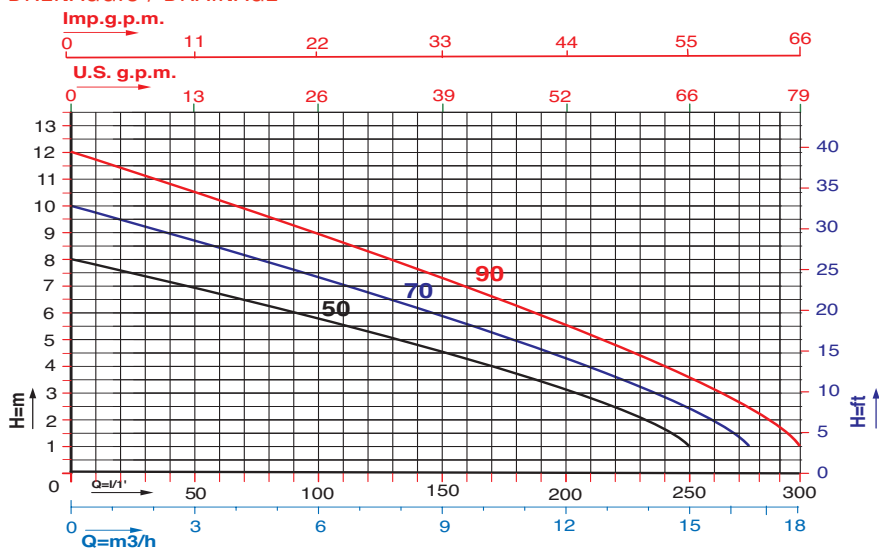

### CARATTERISTICHE COSTRUTTIVE:

Corpo pompa: PP30FV  
Motore: Raffreddato ad acqua/cassa lega G-Al Si 9  
Albero motore: Acciaio inox AISI F - Terminale in ceramica (SPA 700) con camera d'olio  
Classe isolamento: F  
Classe protezione: IP 68  
Tenuta: Paraoli ad alta resistenza  
Utilizzo: Intermittente (SPA 300-SPA 500)

### MAIN FEATURES:

Pump body: PP30FV  
Motor: Water cooled/casing made of G-Al Si 9 alloy  
Motor shaft: Stainless steel AISI 430 F - Ceramic shaft terminal (SPA 700) with oil chamber  
Insulation class: F  
Protection class: IP 68  
Seal: High resistant lip seals  
Duty: Intermittant (SPA 300-SPA 500)

### DIMENSIONI/Dimensions

TYPE	DNA	DNM	a	b	c	d	e	f
SPA 50	-	M 1"1/4	400	152	132	50	285	395
SPA 70	-	F 1"1/4	400	152	132	70	311	440
SPA 90	-	F 1"1/4	400	152	130	70	311	440

### DATI ELETTRICI / ELECTRICAL DATA

TYPE	HP (P2)	kW (P2)	kW (P1)	230V 50Hz ~1	µF	r.p.m.	Temp Max	IMBALLO/Packaging				
								L	N	M	Kg	Q.ty euro pallett
SPA 50	0,60	0,45	0,57	2,55	8	2800	35°C	220	370	170	5,2	100
SPA 70	0,80	0,60	0,76	3,45	12	2800	35°C	220	370	170	6,7	100
SPA 90	0,95	0,70	0,96	4,20	16	2800	35°C	220	370	170	7,8	100

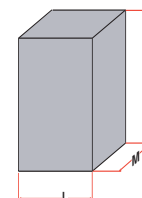

# SPM

## ELETTROPOMPE SOMMERGIBILI IN PLASTICA (VORTEX) PLASTIC SUBMERSIBLE PUMPS



### APPLICAZIONI

- SVUOTAMENTO DA ACQUE PIOVANE D'INFILTRAZIONE, DI POZZETTI O VASCHE DI RACCOLTA
- PRELIEVO DA VASCHE DI RACCOLTA DI ACQUE PIOVANE PER PICCOLE IRRIGAZIONI A SCORRIMENTO DI ORTI E GIARDINI.
- TRAVASO DI ACQUA CHIARA DA SERBATOI E VASCHE

### VORTEX

- PASSAGGIO SOLIDI FINO A 30 MM

### APPLICATIONS

- RAIN, SEEPAGE, SUMP PIT AND CATCH TANK WATER PUMP OUT
- GARDEN AND VEGETABLE GARDEN MINI FLOOD IRRIGATION SYSTEM RAIN WATER CATCH TANK PUMP DOWN
- WHITE WATER PUMP OVER FROM RESERVOIRS AND VATS

### VORTEX

- SOLID MATTER BYPASS UP TO 30 MM

### VORTEX

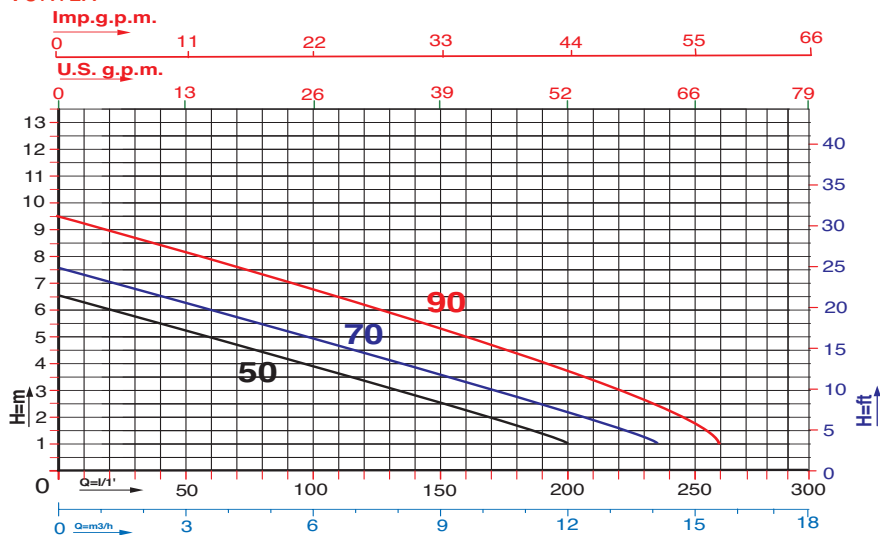

### CARATTERISTICHE COSTRUTTIVE:

Corpo pompa: PP30FV  
 Motore: Raffreddato ad acqua/cassa lega G-Al Si 9  
 Albero motore: Acciaio inox AISI F -  
 Terminale in ceramica (SPA 700) con camera d'olio  
 Classe isolamento: F  
 Classe protezione: IP 68  
 Tenuta: Paraoli ad alta resistenza  
 Utilizzo: Intermittente (SPM 500)

### MAIN FEATURES:

Pump body: PP30FV  
 Motor: Water cooled/casing made of G-Al Si 9 alloy  
 Motor shaft: Stainless steel AISI 430 F -  
 Ceramic shaft terminal (SPA 700) with oil chamber  
 Insulation class: F  
 Protection class: IP 68  
 Seal: High resistant lip seals  
 Duty: Intermittant (SPM 500)

### DIMENSIONI/Dimensions

TYPE	DNA	DNM	a	b	c	d	e	f
SPM 50	Ø30	M 1"1/4	400	152	130	60	295	380
SPM 70	Ø30	F 1"1/4	400	152	130	120	347	440
SPM 90	Ø30	F 1"1/4	400	152	130	120	347	440

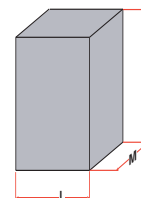

### DATI ELETTRICI / ELECTRICAL DATA

TYPE	HP (P2)	kW (P2)	kW (P1)	230V 50Hz ~1	µF	r.p.m.	Temp Max	IMBALLO/Packaging				
								L	N	M	Kg	Q.ty euro pallett
SPM 50	0,60	0,45	0,52	2,4	8	2800	35°C	220	370	170	5,2	100
SPM 70	0,80	0,60	0,68	3,10	12	2800	35°C	220	370	170	6,6	100
SPM 90	0,95	0,70	0,83	3,65	16	2800	35°C	220	370	170	7,7	100





# MAXIMA

## ELETTROPOMPE SOMMERGIBILI IN PLASTICA DRENAGGIO PER ACQUE SPORCHE (VORTEX) PLASTIC SUBMERSIBLE PUMPS FOR FOUL WASTE WATER DRAINAGE (VORTEX)

### APPLICAZIONI

- SVUOTAMENTO DA ACQUE PIOVANE D'INFILTRAZIONE, DI POZZETTI O VASCHE DI RACCOLTA
- PRELIEVO DA VASCHE DI RACCOLTA DI ACQUE PIOVANE PER PICCOLE IRRIGAZIONI A SCORRIMENTO DI ORTI E GIARDINI.
- TRAVASO DI ACQUA CHIARA DA SERBATOI E VASCHE

### APPLICATIONS

- RAIN, SEEPAGE, SUMP PIT AND CATCH TANK WATER PUMP OUT
- GARDEN AND VEGETABLE GARDEN MINI FLOOD IRRIGATION SYSTEM RAIN WATER CATCH TANK PUMP DOWN
- WHITE WATER PUMP OVER FROM RESERVOIRS AND VATS

### VORTEX

- PASSAGGIO SOLIDI FINO A 30 MM (VXP400)
- PASSAGGIO SOLIDI FINO A 35 MM (VXP550)

### VORTEX

- SOLID MATTER BYPASS UP TO 30 MM (VXP 400)
- SOLID MATTER BYPASS UP TO 35 MM (VXP 550)

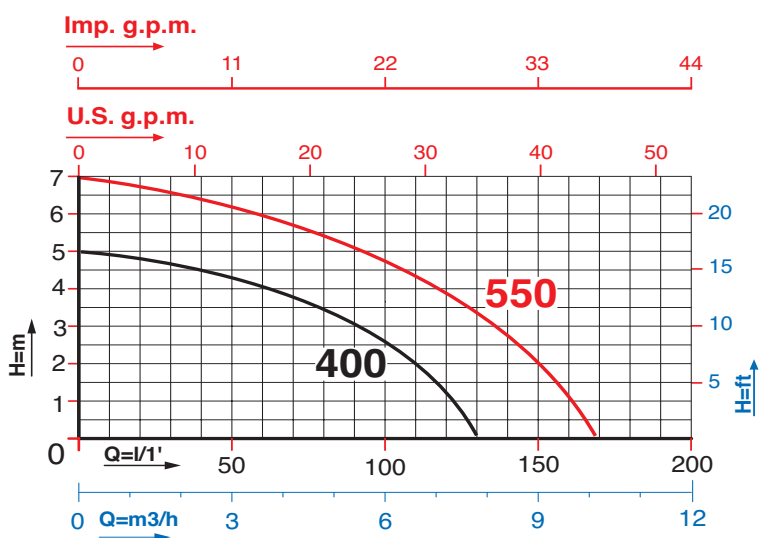

### CARATTERISTICHE COSTRUTTIVE:

Corpo pompa: TECNOPOLIMERO  
Motore: Raffreddato ad acqua  
Albero motore: Acciaio inox AISI  
Classe isolamento: B  
Classe protezione: IP 68  
Tenuta: Paraoli ad alta resistenza  
Utilizzo: Intermittente

### MAIN FEATURES:

Pump body: PP30FV  
Motor: Water cooled  
Motor shaft: Stainless steel  
Insulation class: B  
Protection class: IP 68  
Seal: High resistant lip seals  
Duty: Intermittant

DATI ELETTRICI / ELECTRICAL DATA						IMBALLO/Packaging			
TYPE	HP (P2)	kW (P2)	DNM	r.p.m.	Temp Max	L	N	M	Kg
VXP 400	0,55	0,4	1"	2800	30°C	220	390	175	4,0
VXP 550	0,75	0,55	1" 1/2 1" 1/4	2800	35°C	220	390	175	4,6

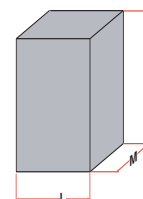

OP

**MOTORE SOMMERSO 4"**  
**SUBMERSIBLE MOTOR 4"**



- OP - B:** Flangia di accoppiamento a norme NEMA4" in Ottone stampato.
- OP - C:** Flangia di accoppiamento a norme NEMA4" in Ghisa trattata anticorrosione.
- OP - S:** Flangia di accoppiamento a norme NEMA4" in AISI 316.

Camicia esterna in AISI 304 - AISI 316.  
 Gruppo prigioniero, rondelle e dadi per accoppiamento pompa in AISI 304 - AISI 316.  
 Terminale albero motore in Duplex®.  
 Potenza: monofase 0,37 kW - 3,7 kW.  
 trifase 0,37 kW - 7,5 kW .  
 Tensioni: monofase 230V ± 10% 50Hz o 60Hz.  
 trifase 230V o 400V ± 10% 50Hz o 60Hz.  
 Carico assiale: 2500N - 4500N.  
 Protezione IP 68, Classe di isolamento F.  
 Cavo piatto 4x1,5mm<sup>2</sup> dimensioni 15,5x5,5mm.  
 Lunghezza: 1,5mt (0,37 kW -1,5 kW)  
 2,5mt (2,2 kW - 5,5 kW)  
 3,0mt (7,5 kW)

**LIMITI D'IMPIEGO**

Numero massimo di avviamenti per ora: 30.  
 Temperatura ambiente max. 35 C, acqua pH 6,5 - 8,0.  
 Velocità min. di raffreddamento 8cm/sec.  
 Profondità massima di immersione 350mt.  
 Montaggio: verticale/orizzontale

**OP - B:** Pressed Brass coupling flange 4" according NEMA rules.

**OP - C:** Cast Iron with anti-corrosive treatment coupling flange 4" according NEMA rules.

**OP - S:** Coupling flange 4" according NEMA rules of SS AISI316.

Outer shell of SS AISI 304 - AISI 316.

Stud-bolt, washers and nuts for pump coupling of SS AISI 304 - AISI 316.

Shaft extension of SS Duplex®.

Power: single-phase 0,37 kW - 3,7 kW.  
 three-phase 0,37 kW - 7,5 kW.

Voltage: single-phase 230V ± 10% 50Hz or 60Hz.  
 three-phase 230V or 400V ± 10% 50Hz or 60Hz.

Axial load: 2500 N - 4500 N.

Protection IP 68, Insulation class F

Flat cable 4x1,5mm<sup>2</sup> dimensions 15,5x5,5mm.

Length: 1,5mt (0,37 kW -1,5 kW)  
 2,5mt (2,2 kW - 5,5 kW)  
 3,0mt (7,5 kW).

**LIMITS OF USE**

Max. starting operations per hour: 30.  
 Max. ambient temperature 35°C, water pH 6,5 - 8,0.  
 Min. cooling speed: 8 cm/sec.  
 Max. depth of immersion: 350 mt.  
 Vertical or horizontal installation.

SERIE	Pn		V	c 450V µF	RPM	cos	n %	In A	S.F.	N	H	m
	kW	Hp									mm	kg
<b>OPM 0500</b>	0,37	0,50	230	20	2840	0,93	58	3,1	1,0	2500	373	7,7
<b>OPM 0750</b>	0,55	0,75	230	25	2820	0,97	64	5,0	1,0	2500	393	8,6
<b>OPM 1000</b>	0,75	1,00	230	36	2840	0,95	69	6,2	1,0	2500	423	9,9
<b>OPM 1500</b>	1,10	1,50	230	40	2830	0,94	71	8,5	1,0	2500	453	11,3
<b>OPM 2000</b>	1,50	2,00	230	50	2840	0,94	73	10,8	1,0	2500	493	13,1
<b>OPM 3000</b>	2,20	3,00	230	80	2840	0,97	74	15,5	1,0	2500	543	15,4
<b>OPM 5000</b>	3,70	5,00	230	125	2840	0,99	74	22,4	1,0	4500	823	27,5

SERIE	Pn		V	RPM	cos	n %	In A	S.F.	N	H	m
	kW	Hp								mm	kg
<b>OPT 0500</b>	0,37	0,50	400	2810	0,78	64	1,2	1,0	2500	373	7,2
<b>OPT 0750</b>	0,55	0,75	400	2810	0,78	67	1,6	1,0	2500	373	7,8
<b>OPT 1000</b>	0,75	1,00	400	2820	0,78	69	2,2	1,0	2500	393	8,8
<b>OPT 1500</b>	1,10	1,50	400	2820	0,78	74	3,0	1,0	2500	423	10,1
<b>OPT 2000</b>	1,50	2,00	400	2820	0,76	76	4,2	1,0	2500	453	11,4
<b>OPT 3000</b>	2,20	3,00	400	2820	0,79	77	6,2	1,0	2500	493	13,2
<b>OPT 4000</b>	3,00	4,00	400	2840	0,85	79	7,1	1,0	2500	513	14,0
<b>OPT 5500</b>	4,00	5,50	400	2840	0,84	80	9,4	1,0	2500	543	16,3
<b>OPT 7500</b>	5,50	7,50	400	2840	0,81	80	13,3	1,0	2500	623	19,6
<b>OPT 1000</b>	7,50	10,00	400	2810	0,76	80	18,0	1,0	4500	853	28,5

Legenda: PN=potenza nominale/rated power, C=condensatore/capacitor, COS =fattore potenza/power factor  
 IN=corrente nominale/rated current, N=carico assiale/axial load



# AP



**ELETTROPOMPE SOMMERSE PER POZZI DA 4" INTERAMENTE IN ACCIAIO INOX AISI 304**  
**SUBMERSED ELECTRIC PUMPS, FOR 4 INCH WELLS FULLY IN STAINLESS STEEL AISI 304**

**PREVALENZA** ..... : 45 mt. ÷ 292 mt.  
**PORTATA** ..... : 2,4 m<sup>3</sup>/h ÷ 18 m<sup>3</sup>/h  
**POTENZA NOMINALE** : 0,75 kW (1HP) ÷ 4 kW (5,5HP)

**PUMP HEAD** ..... : 45,0 mt ÷ 292,0 mt  
**DELIVERY** ..... : 2,4 m<sup>3</sup>/h ÷ 18,0 m<sup>3</sup>/h  
**RATED HORSEPOWER** : 0,75 kW (1,0HP) ÷ 4,0 kW (5,5HP)

## APPLICAZIONI

- APPROVVIGIONAMENTO D'ACQUA
- APPLICAZIONI CIVILI ED INDUSTRIALI
- IMPIANTI ANTINCENDIO
- IMPIANTI D'IRRIGAZIONE

## APPLICATIONS

- WATER SUPPLY
- DOMESTIC AND INDUSTRIAL APPLICATIONS
- FIRE FIGHTING
- IRRIGATION

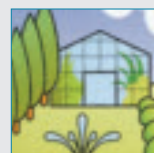
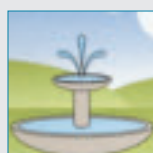
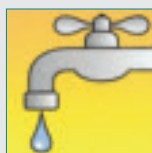

**AV ARVEN**

**CARATTERISTICHE DI COSTRUZIONE:**

- MOTORE A BAGNO D'OLIO ATOSSICO E DIELETTRICO CONFORME ALLE NORME F.D.A. (FOOD AND DRUG ADMINISTRATOR)
- STATORE RIAVVOLGIBILE
- TENUTA MECCANICA CON PROTEZIONE ANTISABBIA
- IMMERSIONE MASSIMA POMPA: MT 150
- GRADO DI PROTEZIONE IP 68.
- CLASSE DI ISOLAMENTO: F
- TEMPERATURA MAX.LIQUIDO POMPATO: 35°C
- VERSIONI: Monofase: 220 - 277V/50Hz o 220 - 277V/60Hz  
Trifase: 380 - 480V/50Hz o 380 - 480V/60Hz
- POTENZA MOTORE: Monofase: 0,75kW A 2,2 kW  
Trifase: 0,75kW A 4 kW
- CAVO STANDARD: PIATTO 4X1,5mm  
lunghezza: 1,5mt (0,75kw - 1,5kw); 2,5 (2,2 kw - 4 kw)  
lunghezza 4X1,5mm : 1,5mt (0,75kw - 1,5kw); 2,5 (2,2 kw - 4 kw)
- Numero massimo di avviamenti per ora equamente distribuiti: 30

SPECIALI VOLTAGGI E FREQUENZE A RICHIESTA.

**DESIGN ENGINEERING:**

- OIL BATH MOTOR ATOSSIC AND DIELETTRIC CONSISTENT TO THE F.D.A. (FOOD AND DRUG ADMINISTRATOR NORMS)
- REWINDABLE STATOR
- MECHANICAL SEAL WITH PROTECTION AGAINST SAND
- PERMISSIBLE DRAUGHT OF WATER: 150 mt
- IP 68 PROTECTION CLASS
- CLASS "F" INSULATION
- MAX PUMP LIQUID TEMPERATURE: 35°
- VERSIONS: Single Phase: 220 - 277V/50Hz or 220 - 277V/60Hz  
Three Phase: 380 - 480V/50Hz or 380 - 480V/60Hz
- MOTOR POWER: Single Phase: 0,75kW A 2,2 kW  
Three Phase: 0,75kW A 4 kW
- STANDARD CABLE FEATURES: WIDE 4X1,5mm  
length: 1,5mt (0,75kw - 1,5kw); 2,5 (2,2 kw - 4 kw)  
4X1,5mm length: 1,5mt (0,75kw - 1,5kw); 2,5 (2,2 kw - 4 kw)
- Maximum numbers of starts for hour at regular intervals: 30

CUSTOMISED VOLTAGE AND FREQUENCY RATING AVAILABLE ON DEMAND

**TABELLA MATERIALI / MATERIALS TABLE:**

Pos.	Componente / Component	Materiale / Materials
A	Testata superiore piattello valvola sede valvola / Upper head, valve plate, valve seat	ACCIAIO INOX / (AISI 304 DIN 1.4301) / STAINLESS STEEL
B	Giranti / Impellers	ACCIAIO INOX / (AISI 304 DIN 1.4301) / STAINLESS STEEL
C	Albero (lato pompa) / Shaft (pump face)	ACCIAIO INOX / (AISI 420) / STAINLESS STEEL
F	Camicia esterna motore/ Outer shell	ACCIAIO INOX / (AISI 304 DIN 1.4301) / STAINLESS STEEL
G	Flangia di accoppiamento/ Connection flange	ACCIAIO INOX / (AISI 304 DIN 1.4301) / STAINLESS STEEL
M	Diffusori/ Diffusers	ACCIAIO INOX / (AISI 304 DIN 1.4301) / STAINLESS STEEL
L	Filtro/Filters	ACCIAIO INOX / (AISI 304 DIN 1.4301) / STAINLESS STEEL

MODELLO type	DIMENSIONI ELETTROPOMPA Dimensions pump A=MM	PESO ELETTROPOMPA Weight pump Kg	HP	DIMENSIONI MOTORE Motor Dimensions B=MM	PESO MOTORE Weight Motor Kg
AP 10-18	532,00	4,9	1,0	423,00	9,9
AP 10-23	637,00	6,0	1,5	453,00	11,3
AP 10-28	742,00	6,8	2,0	493,00	13,1
AP 10-40	1029,00	9,8	3,0	543,00	15,4
AP 18-12	406,00	3,7	1,0	423,00	9,9
AP 18-18	532,00	4,9	1,5	453,00	11,3
AP 18-25	679,00	6,2	2,0	493,00	13,1
AP 18-33	847,00	7,8	3,0	543,00	15,4
AP 18-45	1134,00	10,5	5,0	513,00	14
AP 25-08	322,00	3,0	1,0	423,00	9,9
AP 25-12	406,00	3,6	1,5	453,00	11,3
AP 25-17	511,00	4,6	2,0	493,00	13,1
AP 25-21	595,00	5,5	3,0	543,00	15,4
AP 25-33	847,00	7,6	4,0	513,00	14
AP 25-44	1098,00	10,3	5,5	543,00	16,3
AP 40-12	701,00	7,8	3,0	543,00	15,4
AP 40-18	953,00	10,5	4,0	513,00	14
AP 40-25	1247,00	15,5	5,5	543,00	16,3
AP 70-07	636,00	6,6	3,0	543,00	15,4
AP 70-10	831,00	8,7	4,0	513,00	14
AP 70-13	1026,00	10,7	5,5	543,00	16,3

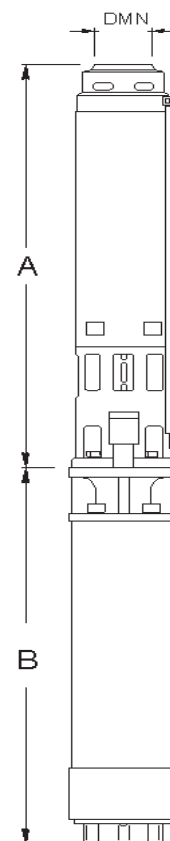

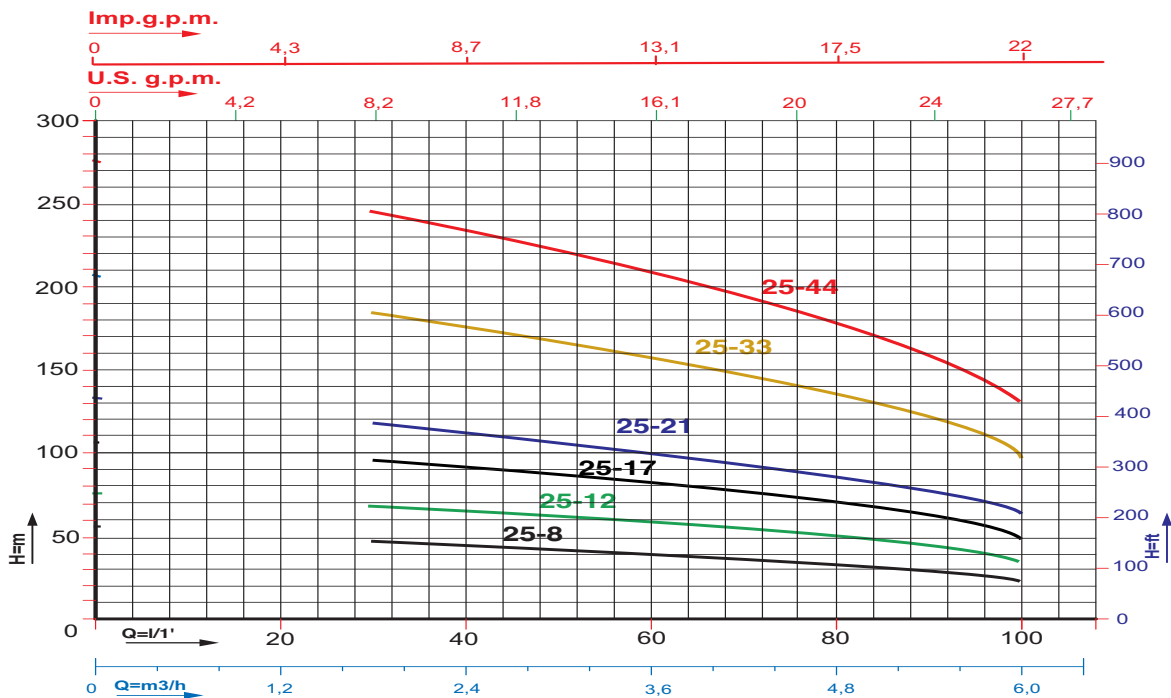
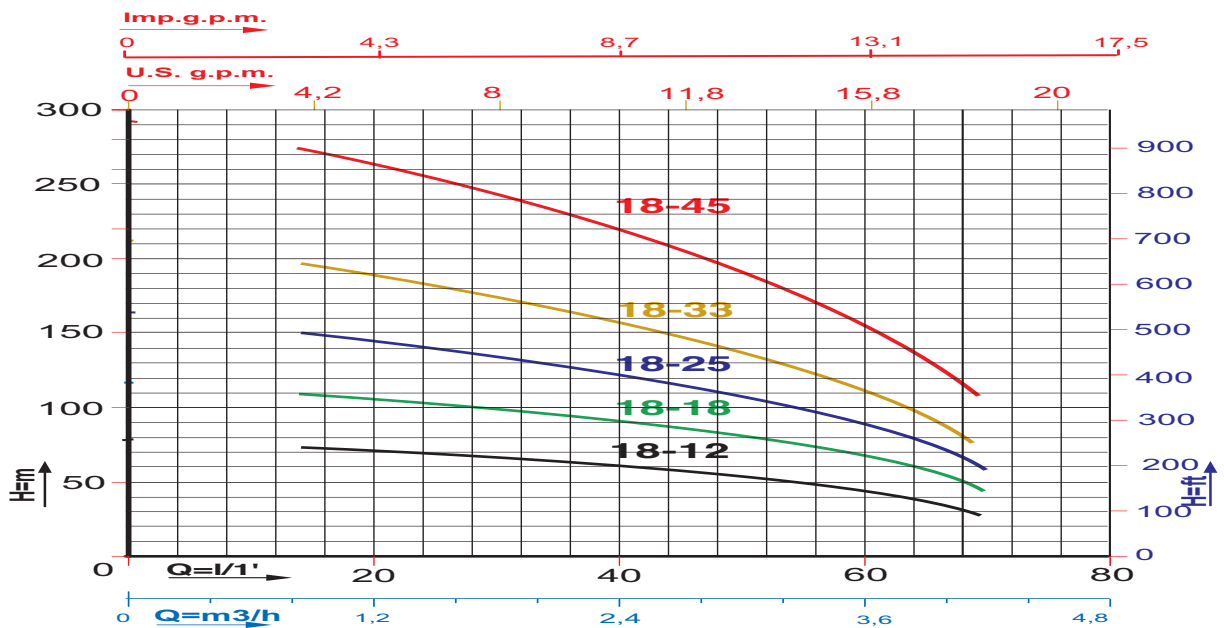
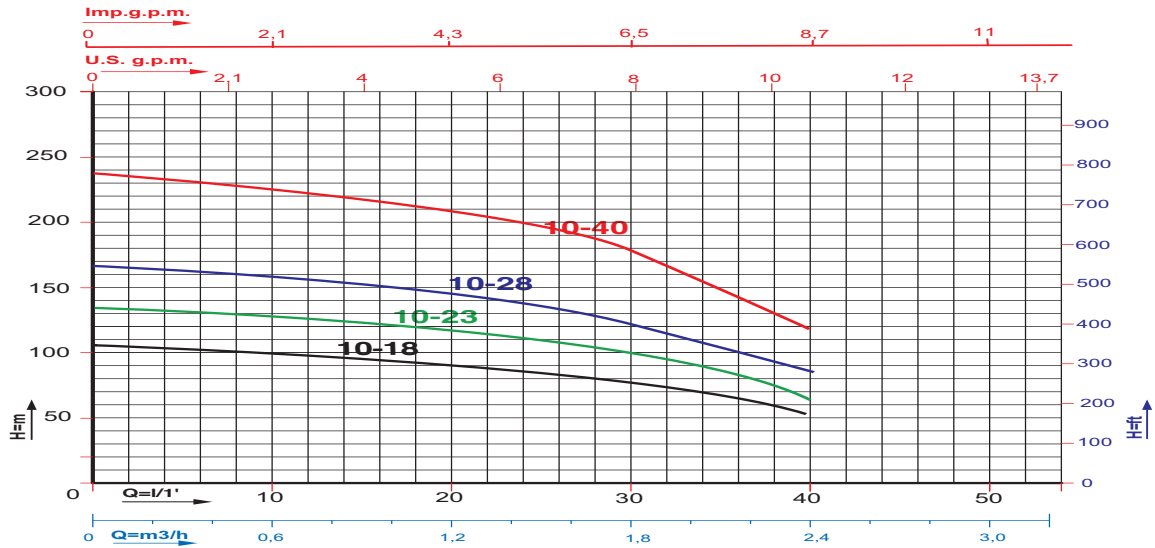

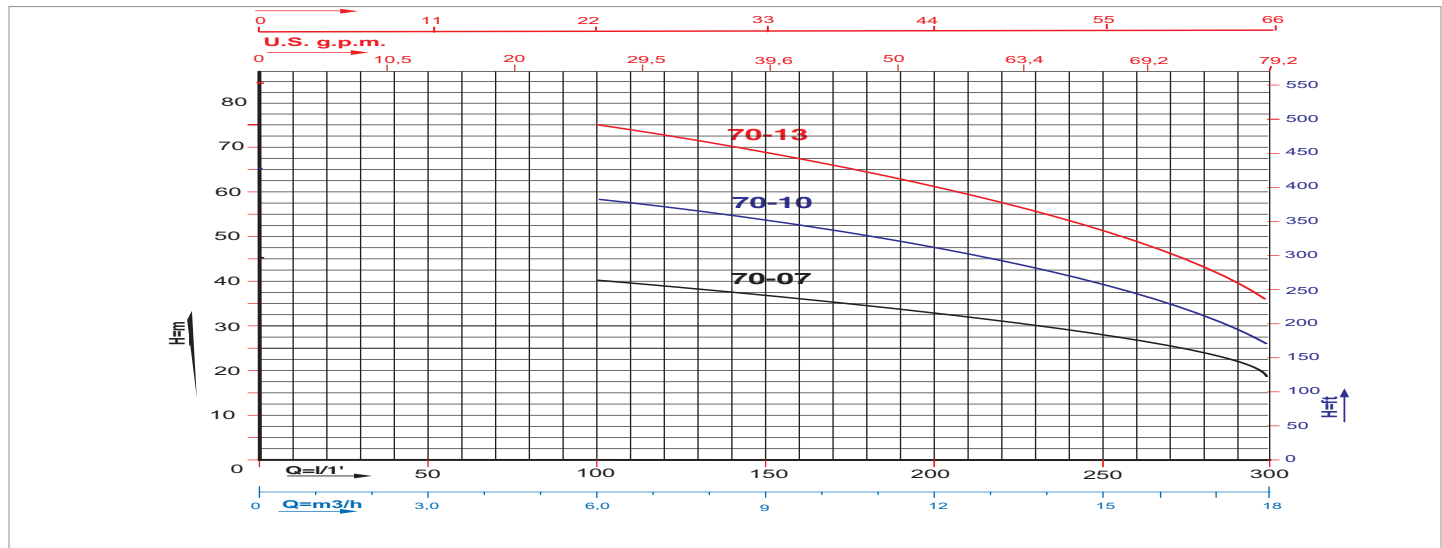
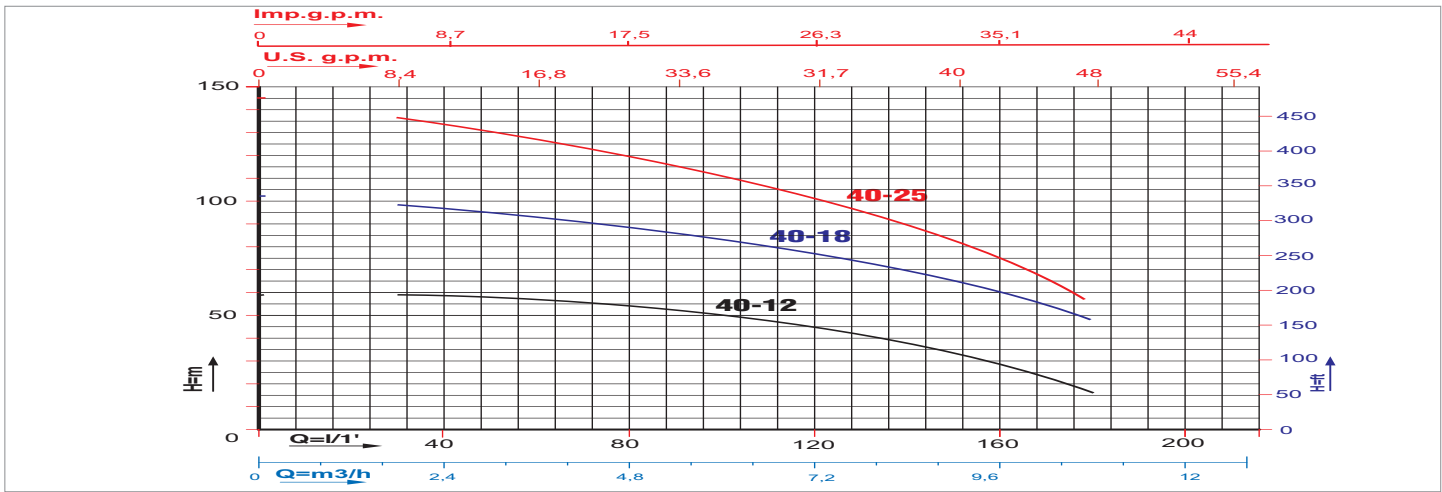

Caratteristiche di funzionamento a 2800 rpm 50Hz e 3450 rpm 60Hz - Performances at 2800 rpm 50 Hz and 3450 rpm 60 Hz  
 Le prestazioni valgono per liquidi con densità  $\rho = 1,0 \text{ kg/dm}^3$  ed una viscosità  $\nu = 1 \text{ mm}^2/\text{s}$  / The performance data holds true for liquids with a  $\rho = 1,0 \text{ kg/dm}^3$  density and a  $\nu = 1 \text{ mm}^2/\text{s}$  viscosity.

MODELLO MODEL	STADI STAGE	VOLTAGGIO 50H VOLTAGE 50H		DATI ELETTRICI / ELECTRICAL DATA				DATI IDRAULICI / HYDRAULIC DATA														
		1X230-M	3X380-T	DNM	P2 nom		Condensatore Capacitor		PREVALENZA TOTALE IN METRI COLONNA ACQUA / TOTAL PUMP HEAD AND WATER COLUMN HEIGHT IN m.													
					kw		HP		μF	vc												
AP 10-18	18	▪	▪	1"1/4	0,75	1,00	36	450			0	0,9	1,5	1,8	2,4	4,2	6	8,4	10,8	15	18	
AP 10-23	23	▪	▪	1"1/4	1,10	1,50	40	450	0	15	25	30	40	70	100	140	180	250	300			
AP 10-28	28	▪	▪	1"1/4	1,50	2,00	50	450	106	98	84	77	51									
AP 10-40	40	▪	▪	1"1/4	2,20	3,00	80	450	136	124	108	98	67									
AP 18-12	12	▪	▪	1"1/4	0,75	1,00	36	450	166	155	134	120	82									
AP 18-18	18	▪	▪	1"1/4	1,10	1,50	40	450	236	218	190	170	119									
AP 18-25	25	▪	▪	1"1/4	1,50	2,00	50	450	78		67	65	59	28								
AP 18-33	33	▪	▪	1"1/4	2,20	3,00	80	450	117		101	98	89	42								
AP 18-45	45	▪	▪	1"1/4	3,70	5,00	---	---	162		140	134	121	58								
AP 25-08	8	▪	▪	1"1/2	0,75	1,00	36	450	212		180	173	160	73								
AP 25-12	12	▪	▪	1"1/2	1,10	1,50	40	450	292		250	243	223	107								
AP 25-17	17	▪	▪	1"1/2	1,50	2,00	50	450	57			44	42	35	22							
AP 25-21	21	▪	▪	1"1/2	2,20	3,00	80	450	75			68	65	53	36							
AP 25-33	33	▪	▪	1"1/2	3,00	4,00	---	---	106			95	90	73	50							
AP 25-44	44	▪	▪	1"1/2	4,00	5,50	---	---	131			117	110	90	62							
AP 40-12	12	▪	▪	2"	2,20	3,00	80	450	206			182	173	142	98							
AP 40-18	18	▪	▪	2"	3,00	4,00	---	---	275			244	232	191	130							
AP 40-25	25	▪	▪	2"	4,00	5,50	---	---	69				63	60	57	49	32					
AP 70-07	7	▪	▪	2"	2,20	3,00	80	450	103				91	87	81	70	48					
AP 70-10	10	▪	▪	2"	3,00	4,00	---	---	144				131	122	113	97	61					
AP 70-13	13	▪	▪	2"	4,00	5,50	---	---	45						40	37	35	26	18			
									65						58	54	50	38	26			
									85						75	70	65	49	34			



# ST



## **ELETTROPOMPE SOMMERSE PER POZZI DA 4'' SUBMERSED ELECTRIC PUMPS, FOR 4 INCH WELLS**

**PREVALENZA** ..... : 26 mt. ÷ 322 mt.  
**PORTATA** ..... : 1,5 m<sup>3</sup>/h ÷ 24 m<sup>3</sup>/h  
**POTENZA NOMINALE** : 0,37 kW (0,5HP) ÷ 7,5 kW (10HP)

**PUMP HEAD** ..... : 26,0 mt ÷ 322,0 mt  
**DELIVERY** ..... : 1,5 m<sup>3</sup>/h ÷ 24,0 m<sup>3</sup>/h  
**RATED HORSEPOWER** : 0,37 kW (0,5HP) ÷ 7,5 kW (10,0HP)

### **APPLICAZIONI**

- APPROVVIGIONAMENTO D'ACQUA
- APPLICAZIONI CIVILI ED INDUSTRIALI
- IMPIANTI ANTINCENDIO
- IMPIANTI D'IRRIGAZIONE

### **APPLICATIONS**

- WATER SUPPLY
- DOMESTIC AND INDUSTRIAL APPLICATIONS
- FIRE FIGHTING
- IRRIGATION

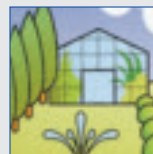
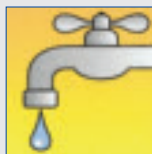
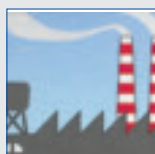

**AV ARVEN**

**CARATTERISTICHE DI COSTRUZIONE:**

- MOTORE A BAGNO D'OLIO ATOSSICO E DIELETRICO CONFORME ALLE NORME F.D.A. (FOOD AND DRUG ADMINISTRATOR)
- STATORE RIAVVOLGIBILE
- TENUTA MECCANICA CONPROTEZIONE ANTISABBIA
- IMMERSIONE MASSIMA POMPA: MT 150
- GRADO DI PROTEZIONE IP 68.
- CLASSE DI ISOLAMENTO: F
- TEMPERATURA MAX.LIQUIDO POMPATO: 35°C
- VERSIONI: Monofase: 220 - 277V/50Hz  
Trifase: 380 - 480V/50Hz
- POTENZA MOTORE: Monofase: 0,75kW A 2,2 kW  
Trifase: 0,75kW A 4 kW
- CAVO STANDARD: PIATTO 4X1,5mm lunghezza: 1,5mt (0,75kw - 1,5kw); 2,5 (2,2 kw - 5,5 kw),3mt (7,5kW)

SPECIALI VOLTAGGI E FREQUENZE A RICHIESTA.

**DESIGN ENGINEERING**

- OIL BATH MOTOR ATOSSIC AND DIELETRIC CONSISTEN TO THE F.D.A. (FOOD AND DRUG AMMINISTRATOR NORMS)
- REWINDABLE STATOR
- MECHANICAL SEAL WITH PROTECTION AGAINST SAND
- PERMISSIBLE DRAUGHT OF WATER: 150 mt
- IP 68 PROTECTION CLASS
- CLASS "F" INSULATION
- MAX PUMP LIQUID TEMPERATURE: 35°
- VERSIONS: Single Phase: 220-277V/50Hz  
Three Phase: 380-480V/50Hz
- MOTOR POWER: Single Phase: From 0,75kW To 2,2 kW  
Three Phase: From 0,75 kW To 4 kW
- STANDARD CABL FEATURES:WIDE 4X1,5MM LENGHT; 1,5mt (o.75kW-1,5kW); 2,5 (2,2 kW-5,5kW), 3mt (7,5 kW)

CUSTOMISED VOLTAGE AND FREQUENCY RATING AVAILABLE ON DEMAND.

**TABELLA MATERIALI / MATERIALS TABLE:**

Pos.	Componente / Component	Materiale / Materials
A	Testata superiore piattello o valvola/ Upper head, valve plate	ACCIAIO INOX (AISI 304 DIN 1.4301) / STAINLESS STEEL
B	Girante / Impeller	TECNOPOLIMERO / TECNOPOLYMER
C	Albero (lato pompa) / Shaft (pump face)	ACCIAIO INOX / (AISI 420) / STAINLESS STEEL
F	Camicia esterna motore / Outer shell	ACCIAIO INOX (AISI 304 DIN 1.4301) / STAINLESS STEEL
G	Flangia di accoppiamento/ Connection flange	OTTONE / BRASS
M	Diffusori / Diffusers	TECNOPOLIMERO / TECNOPOLYMER
L	Filtro / Filters	ACCIAIO INOX (AISI 304 DIN 1.4301) / STAINLESS STEEL

MODELLO TYPE	DIMENSIONI ELETTROPOMPA Dimensionspumpm A=MM	PESO ELETTROPOMPA Weight pumpm Kg	HP	DIMENSIONI MOTORE Motor Dimensions B=MM	PESO MOTORE Weight Motor Kg
ST 05-10	324,00	3,3	0,50	373,00	7,70
ST 05-13	377,00	3,7	0,50	373,00	7,70
ST 05-19	481,00	4,7	0,75	393,00	8,60
ST 05-26	642,00	5,8	1,00	423,00	9,60
ST 10-07	271,00	2,8	0,50	373,00	7,70
ST 10-10	324,00	3,3	0,75	393,00	8,60
ST 10-14	394,00	3,9	1,00	423,00	9,90
ST 10-20	499,00	4,9	1,50	453,00	11,3

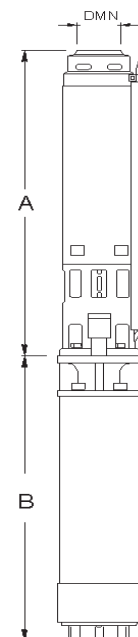

<b>MODELLO</b> <i>type</i>	<b>DIMENSIONI</b> <b>ELETTROPOMPA</b> <i>Dimensionspumpm</i> <b>A=MM</b>	<b>PESO</b> <b>ELETTROPOMPA</b> <i>Weight pumpm</i> <b>KG</b>	<b>HP</b>	<b>DIMENSIONI</b> <b>MOTORE</b> <i>Motor Dimensions</i> <b>B=MM</b>	<b>PESO</b> <b>MOTORE</b> <i>Weight Motor</i> <b>KG</b>
<b>ST 13-05</b>	236,00	2,5	0,50	373,00	7,70
<b>ST 13-08</b>	289,00	2,9	0,75	393,00	8,60
<b>ST 13-11</b>	342,00	3,4	1,00	423,00	9,90
<b>ST 13-16</b>	430,00	4,2	1,50	453,00	11,3
<b>ST 13-21</b>	519,00	5,0	2,00	493,00	13,1
<b>ST 13-32</b>	749,00	7,1	3,00	543,00	15,4
<b>ST 18-05</b>	257,00	2,7	0,50	373,00	7,70
<b>ST 18-07</b>	301,00	3,0	0,75	393,00	8,60
<b>ST 18-09</b>	344,00	3,3	1,00	423,00	9,90
<b>ST 18-14</b>	452,00	4,1	1,50	453,00	11,3
<b>ST 18-18</b>	538,00	4,7	2,00	493,00	13,1
<b>ST 18-27</b>	767,00	6,2	3,00	513,00	14,0
<b>ST 18-35</b>	934,00	7,9	4,00	543,00	15,4
<b>ST 18-48</b>	1250,00	9,9	5,50	543,00	16,3
<b>ST 25-08</b>	345,00	3,3	1,00	423,00	9,90
<b>ST 25-12</b>	433,00	4,1	1,50	453,00	11,3
<b>ST 25-16</b>	542,00	5,0	2,00	493,00	13,1
<b>ST 25-24</b>	777,00	6,6	3,00	513,00	14,0
<b>ST 25-32</b>	965,00	8,7	4,00	543,00	15,4
<b>ST 25-40</b>	1160,00	10,4	5,50	543,00	16,3
<b>ST 25-44</b>	1296,00	11,2	5,50	543,00	16,3
<b>ST 35-07</b>	390,00	3,7	1,00	423,00	9,90
<b>ST 35-10</b>	483,00	4,6	1,50	453,00	11,3
<b>ST 35-14</b>	607,00	5,7	2,00	493,00	13,1
<b>ST 35-20</b>	831,00	7,5	3,00	513,00	14,0
<b>ST 35-27</b>	1048,00	9,6	4,00	543,00	15,4
<b>ST 35-34</b>	1257,00	11,6	5,50	543,00	16,3
<b>ST 35-36</b>	1318,00	12,2	5,50	543,00	16,3
<b>ST 35-49</b>	1802,00	15,9	7,50	623,00	20,0
<b>ST 40-04</b>	294,00	2,8	1,00	423,00	9,90
<b>ST 40-06</b>	356,00	3,4	1,50	453,00	11,3
<b>ST 40-08</b>	418,00	4,0	2,20	493,00	13,1
<b>ST 40-13</b>	573,00	5,5	3,00	513,00	14,0
<b>ST 40-17</b>	697,00	6,6	4,00	543,00	15,4
<b>ST 40-23</b>	921,00	8,4	5,50	543,00	16,3
<b>ST 40-32</b>	1238,00	11,0	7,50	623,00	20,0
<b>ST 80-08</b>	676,00	6,3	3,00	513,00	14,0
<b>ST 80-11</b>	880,00	8,1	4,00	543,00	15,4
<b>ST 80-15</b>	1149,00	10,5	5,50	543,00	16,3
<b>ST 80-20</b>	1489,00	13,5	7,50	623,00	25,5
<b>ST 80-26</b>	1810,00	17,5	10,00	703,00	25,5

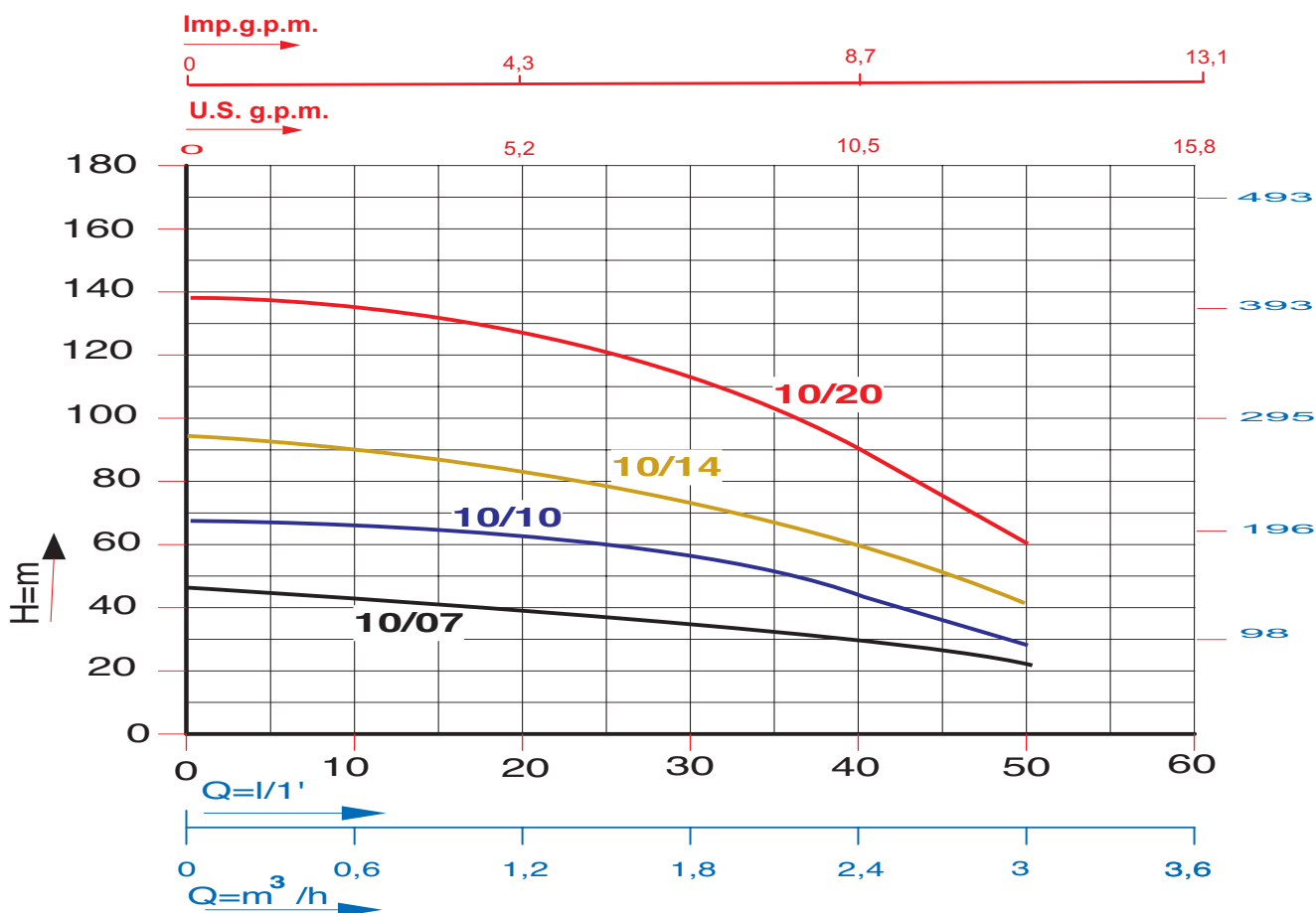
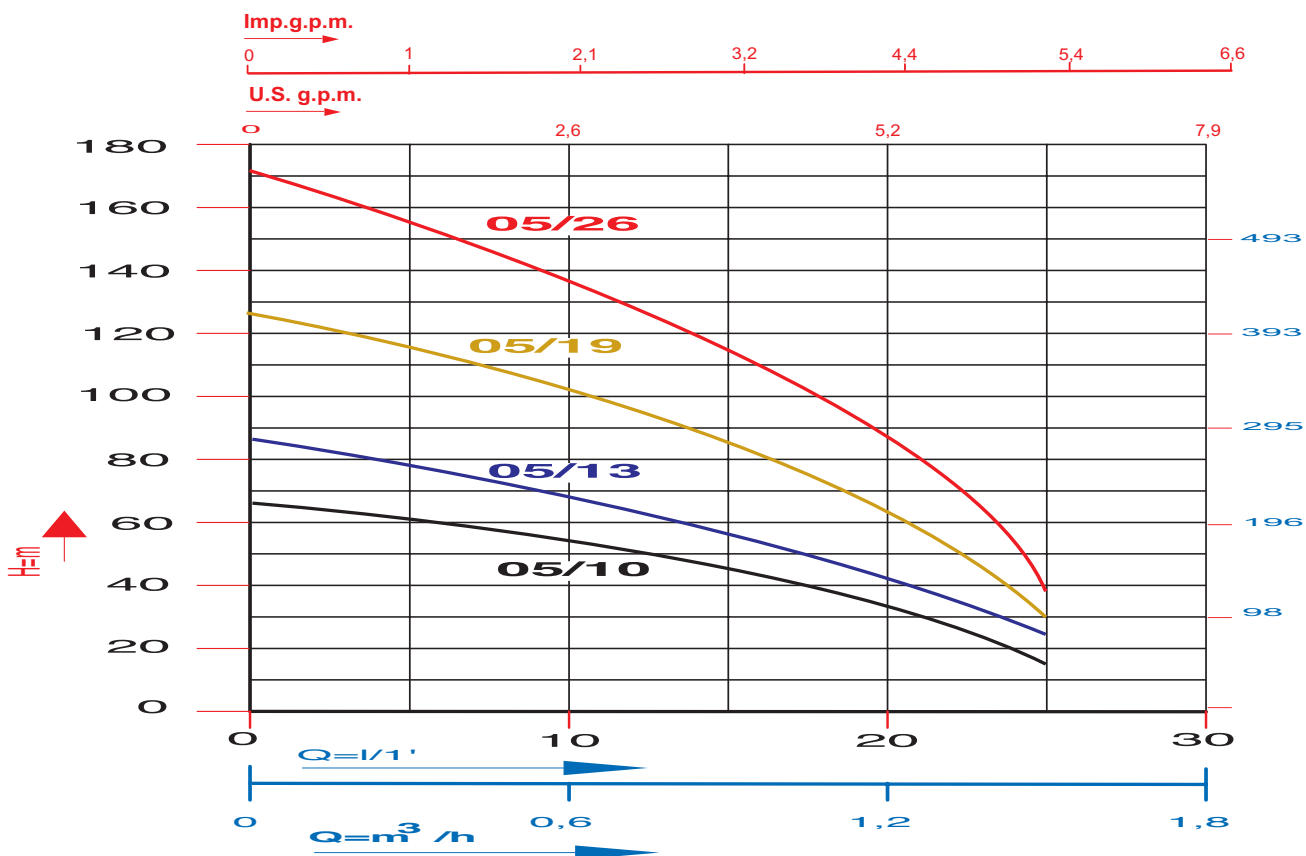

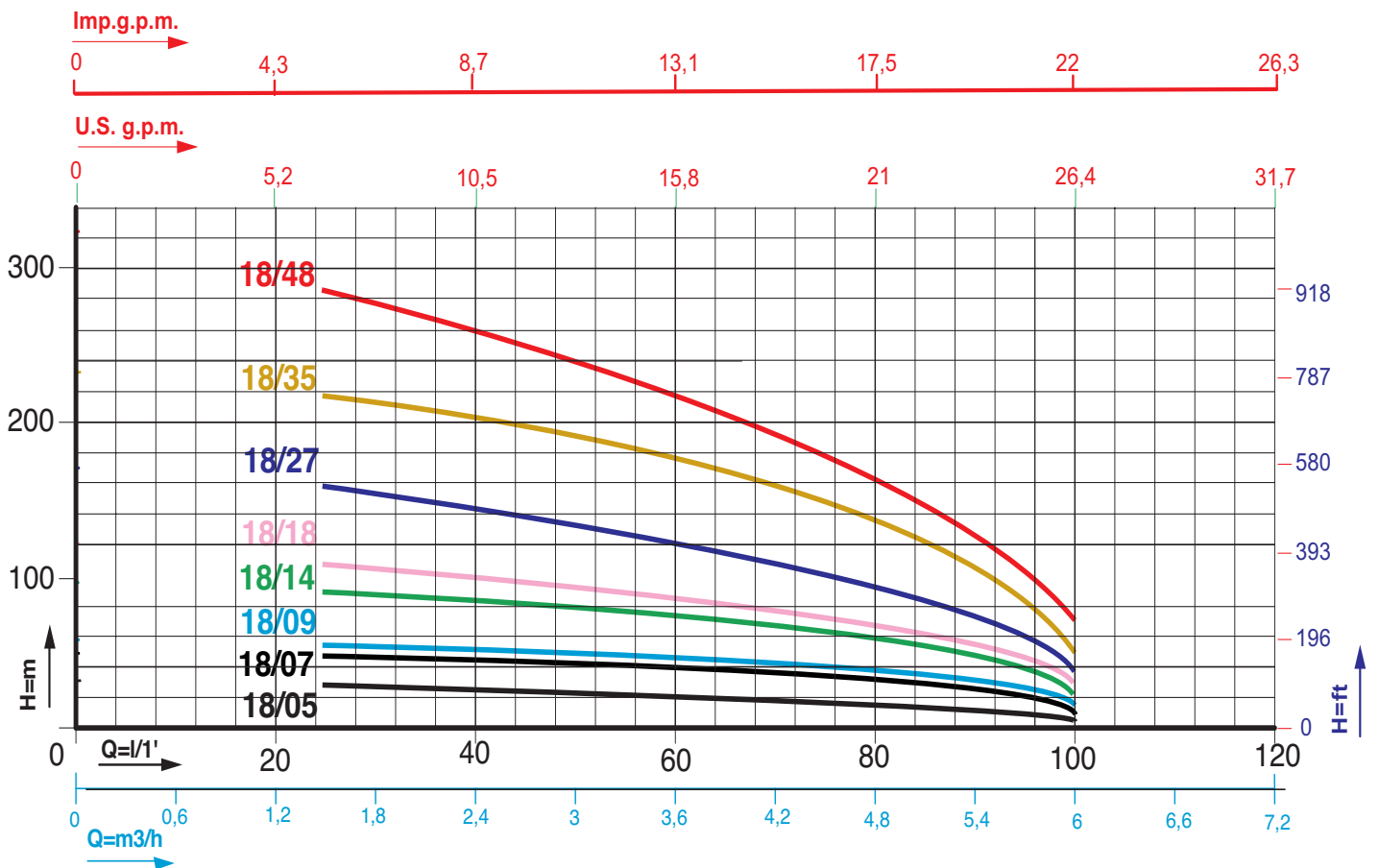
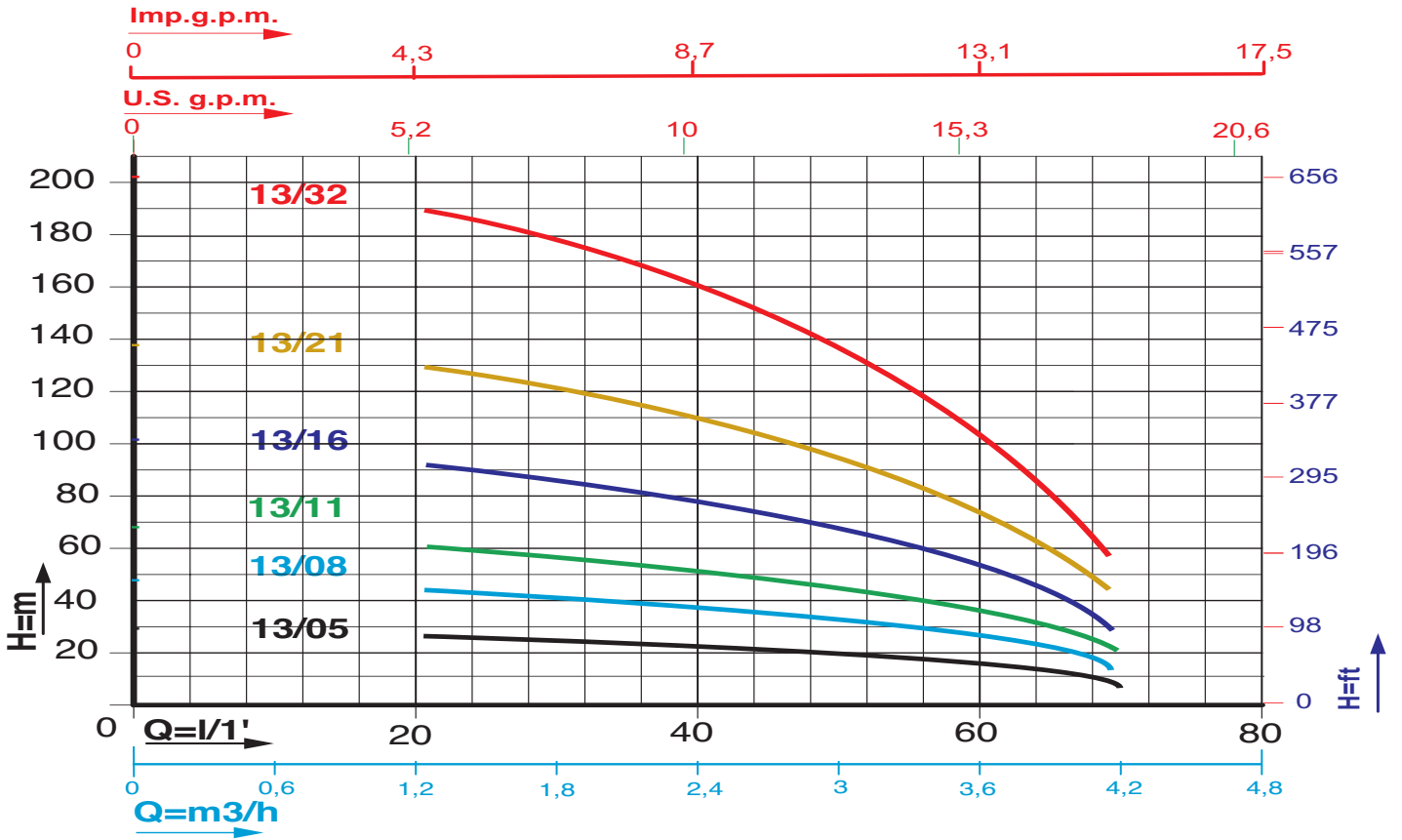

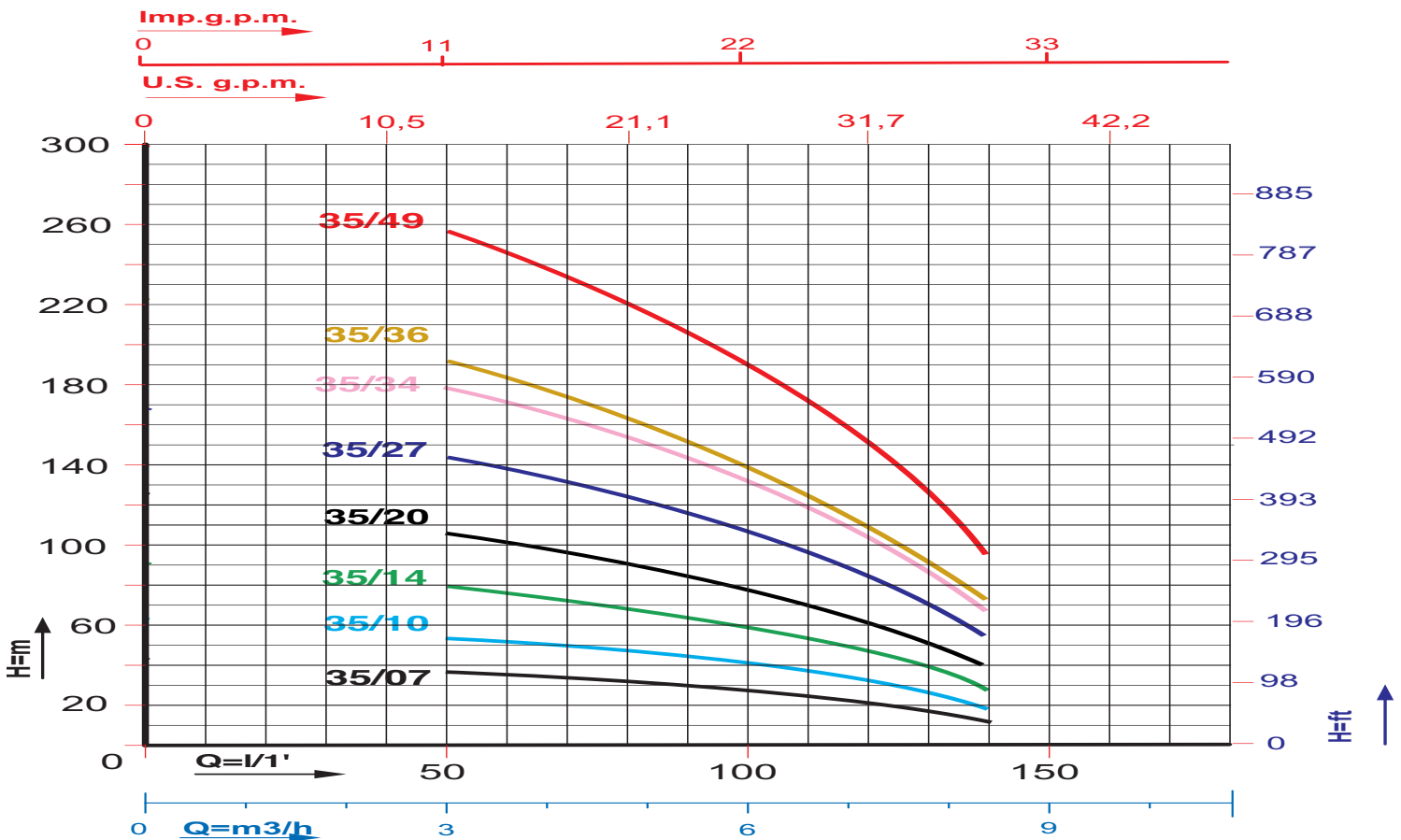
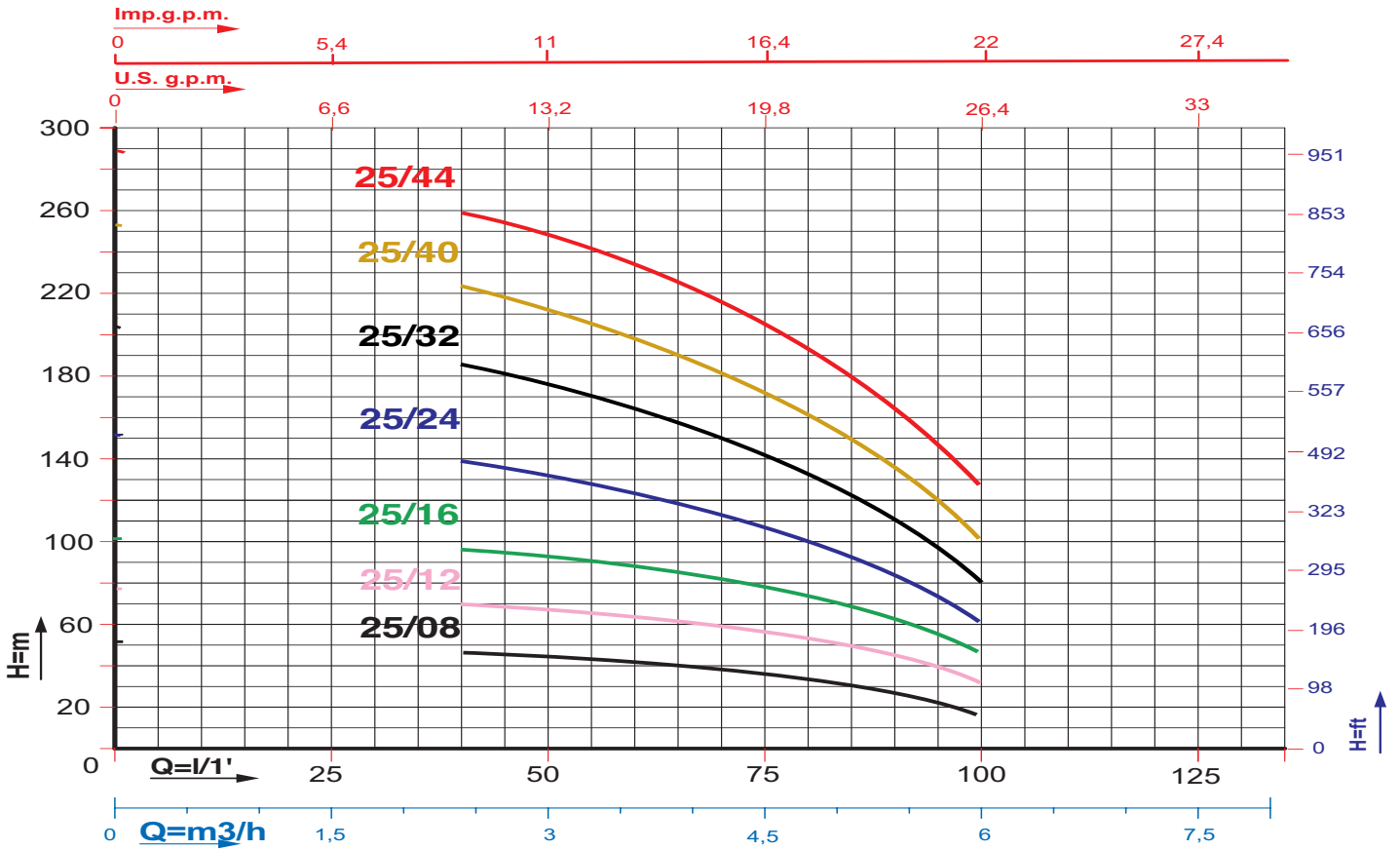



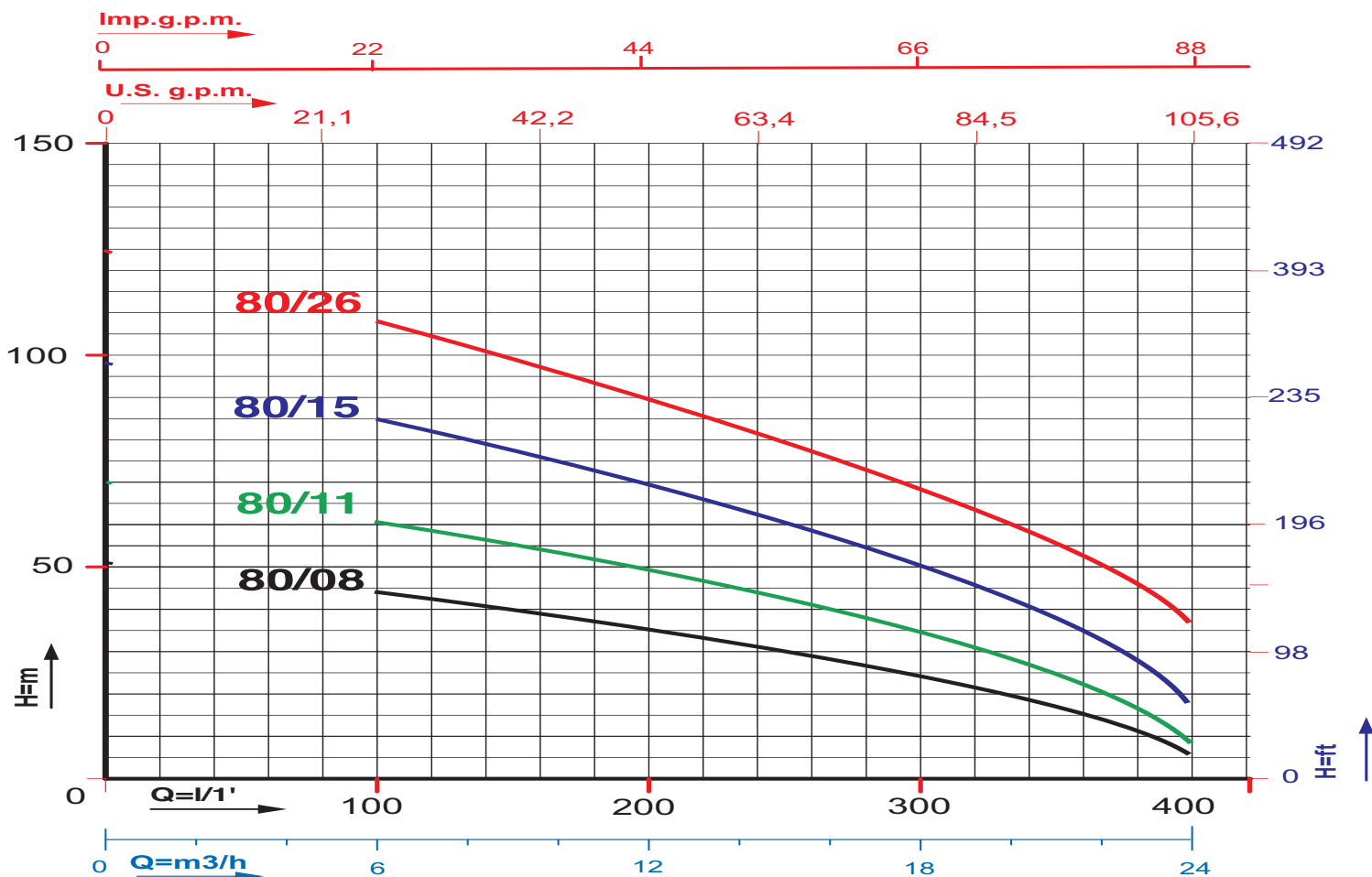
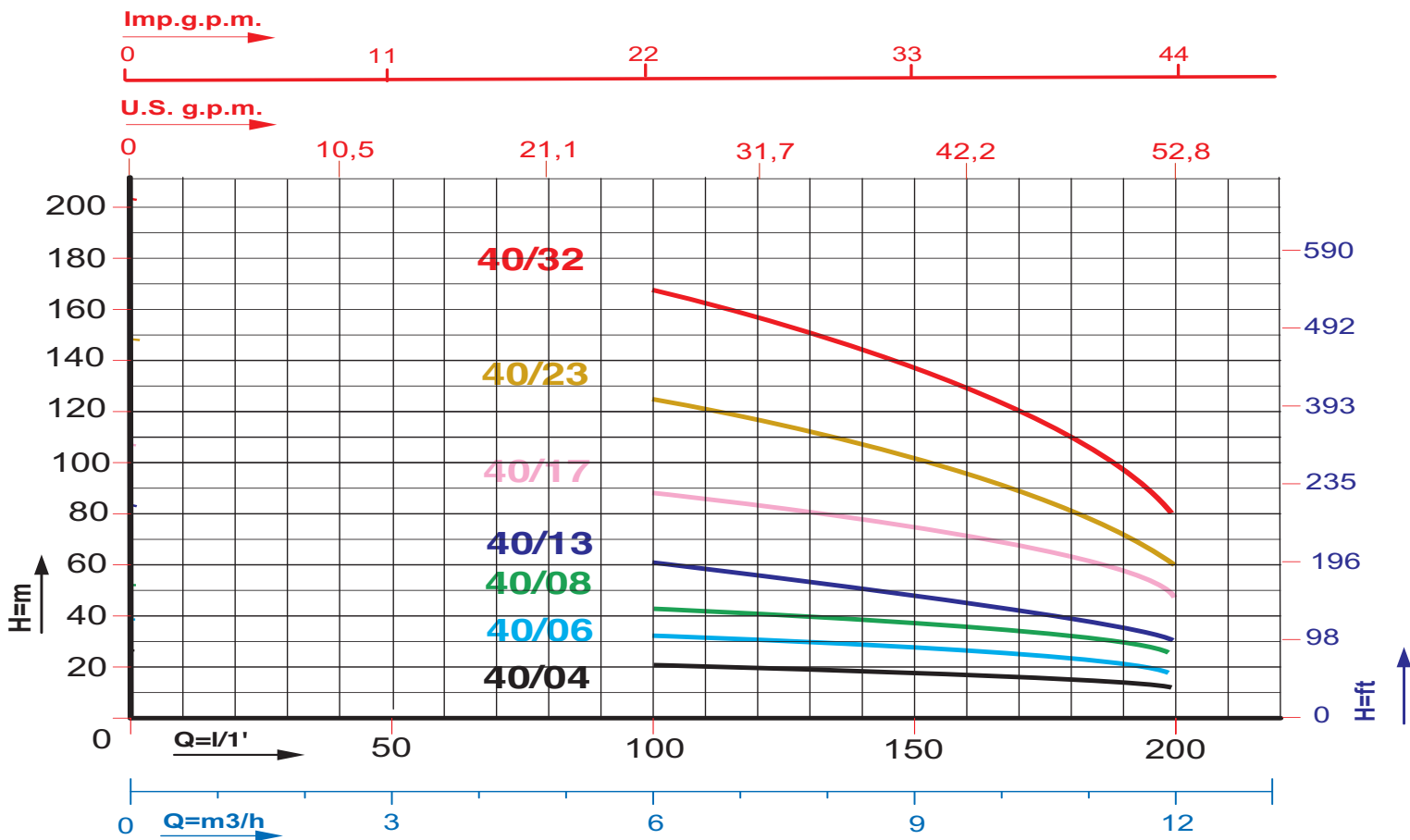

Caratteristiche di funzionamento a 2800 rpm 50Hz e 3450 rpm 60Hz - Performances at 2800 rpm 50 Hz and 3450 rpm 60 Hz  
 Le prestazioni valgono per liquidi con densità  $\rho = 1,0 \text{ kg/dm}^3$  ed una viscosità  $\nu = 1 \text{ mm}^2/\text{s}$  / The performance data holds true for liquids with a  $\rho = 1,0 \text{ kg/dm}^3$  density and a  $\nu = 1 \text{ mm}^2/\text{s}$  viscosity.

MODELLO <i>MODEL</i>	STADI <i>STAGE</i>	VOLTAGGIO 50H <i>VOLTAGE 50H</i>		DATI ELETTRICI / <i>ELECTRICAL DATA</i>					DATI IDRAULICI / <i>HYDRAULIC DATA</i>													
		1X230-M	3X380-T	DNM	P2 nom		Condensatore Capacitor		m <sup>3</sup> /h	0	0,9	1,5	2,4	3	4,2	6	8,4	10,8	12	18	24	
					kw	HP	µF	vC	l/min.	0	15	25	40	50	70	100	140	180	200	300	400	
ST 05-10	10	▪	▪	1"1/4	0,37	0,50	20	450	H (m)	67	46	18										
ST 05-13	13	▪	▪	1"1/4	0,37	0,50	20	450		86	56	23										
ST 05-19	19	▪	▪	1"1/4	0,55	0,75	25	450		126	86	30										
ST 05-26	26	▪	▪	1"1/4	0,75	1,00	36	450		173	117	39										
ST 10-07	7	▪	▪	1"1/4	0,37	0,50	20	450		46	43	39	29	22								
ST 10-10	10	▪	▪	1"1/4	0,55	0,75	25	450		69	65	60	44	29								
ST 10-14	14	▪	▪	1"1/4	0,75	1,00	36	450		92	86	79	60	42								
ST 10-20	20	▪	▪	1"1/4	1,10	1,50	40	450		139	131	120	90	60								
ST 13-05	5	▪	▪	1"1/4	0,37	0,50	20	450		34		31	28	24	13							
ST 13-08	8	▪	▪	1"1/4	0,55	0,75	25	450		54		50	43	38	19							
ST 13-11	11	▪	▪	1"1/4	0,75	1,00	36	450		72		66	58	49	26							
ST 13-16	16	▪	▪	1"1/4	1,10	1,50	40	450		106		98	83	70	33							
ST 13-21	21	▪	▪	1"1/4	1,50	2,00	50	450		142		132	115	100	49							
ST 13-32	32	▪	▪	1"1/4	2,20	3,00	80	450		208		194	165	138	62							
ST 18-05	5	▪	▪	1"1/4	0,37	0,50	20	450		33		29	26	24	18	3						
ST 18-07	7	▪	▪	1"1/4	0,55	0,75	25	450		46		43	40	37	28	7						
ST 18-09	9	▪	▪	1"1/4	0,75	1,00	36	450		59		55	51	47	37	10						
ST 18-14	14	▪	▪	1"1/4	1,10	1,50	40	450		93		87	81	76	58	20						
ST 18-18	18	▪	▪	1"1/4	1,50	2,00	50	450		120		113	105	98	75	25						
ST 18-27	27	▪	▪	1"1/4	2,20	3,00	80	450	175		164	152	141	109	35							
ST 18-35	35	▪	▪	1"1/4	3,00	4,00	---	---	231		217	202	189	149	50							
ST 18-48	48	▪	▪	1"1/4	4,00	5,50	---	---	322		299	276	256	199	70							
ST 25-08	8	▪	▪	1"1/4	0,75	1,00	36	450	51		46	43	35	18								
ST 25-12	12	▪	▪	1"1/4	1,10	1,50	40	450	77		71	68	57	31								
ST 25-16	16	▪	▪	1"1/4	1,50	2,00	50	450	102		96	92	77	46								
ST 25-24	24	▪	▪	1"1/4	2,20	3,00	80	450	151		139	132	111	62								
ST 25-32	32	▪	▪	1"1/4	3,00	4,00	---	---	203		185	175	146	80								
ST 25-40	40	▪	▪	1"1/4	4,00	5,50	---	---	253		227	216	182	102								
ST 25-44	44	▪	▪	1"1/4	4,00	5,50	---	---	278		260	247	210	127								
ST 35-07	7	▪	▪	2"	0,75	1,00	36	450	42			36	32	25	11							
ST 35-10	10	▪	▪	2"	1,10	1,50	40	450	62			53	48	38	18							
ST 35-14	14	▪	▪	2"	1,50	2,00	50	450	90			77	71	59	28							
ST 35-20	20	▪	▪	2"	2,20	3,00	80	450	125			107	97	80	40							
ST 35-27	27	▪	▪	2"	3,00	4,00	---	---	169			145	131	107	55							
ST 35-34	34	▪	▪	2"	4,00	5,50	---	---	208			178	162	132	66							
ST 35-36	36	▪	▪	2"	4,00	5,50	---	---	221			190	173	143	72							
ST 35-49	49	▪	▪	2"	5,50	7,50	---	---	302			257	234	193	96							
ST 40-04	4	▪	▪	2"	0,75	1,00	36	450	26					22	19	15	12					
ST 40-06	6	▪	▪	2"	1,10	1,50	40	450	39					34	29	22	17					
ST 40-08	8	▪	▪	2"	1,50	2,00	50	450	52					46	39	29	24					
ST 40-13	13	▪	▪	2"	2,20	3,00	80	450	82					71	59	40	30					
ST 40-17	17	▪	▪	2"	3,00	4,00	---	---	108					94	79	58	46					
ST 40-23	23	▪	▪	2"	4,00	5,50	---	---	148					127	108	79	60					
ST 40-32	32	▪	▪	2"	5,50	7,50	---	---	202					172	143	105	80					
ST 80-08	8	▪	▪	2"	2,20	3,00	80	450	51						41	37	35	24	12			
ST 80-11	11	▪	▪	2"	3,00	4,00	---	---	70						57	52	49	34	18			
ST 80-15	15	▪	▪	2"	4,00	5,50	---	---	97						79	73	69	50	27			
ST 80-20	20	▪	▪	2"	5,50	7,50	---	---	125						102	94	89	65	37			
ST 80-26	26	▪	▪	2"	7,50	10,00	---	---	160						125	115	110	85	45			

PREVALENZA TOTALE in METRI COLONNA ACQUA / TOTAL PUMP HEAD AND WATER COLUMN HEIGHT IN M.

POMPE SOMMERSE  
SUBMERSIBLE PUMPS

# PMF



## ELETTROPOMPE PERIFERICHE PERIPHERAL ELECTRIC PUMPS

**PREVALENZA** ..... : 34 mt. ÷ 93 mt.  
**PORTATA** ..... : 2,4 m<sup>3</sup>/h ÷ 4,2 m<sup>3</sup>/h  
**POTENZA NOMINALE** : 0,37 kW (0,5HP) ÷ 1,5 kW (2,0HP)

### APPLICAZIONI

- PRESSURIZZAZIONE DI IMPIANTI DOMESTICI E PICCOLA IRRIGAZIONE
- MOVIMENTAZIONE DI LIQUIDI NON AGGRESSIVI PER USI CIVILI ED INDUSTRIALI
- IMPIANTI DI LAVAGGIO, INSERIMENTO SU MACCHINARI PIU' COMPLESSI PER USI INDUSTRIALI

**PUMP HEAD** ..... : 34,0 mt ÷ 93,0 mt  
**DELIVERY** ..... : 2,4 m<sup>3</sup>/h ÷ 4,2 m<sup>3</sup>/h  
**RATED HORSEPOWER** : 0,37 kW (0,5HP) ÷ 1,5 kW (2,0HP)

### APPLICATIONS

- FOR DOMESTIC SYSTEMS AND SMALL IRRIGATION SYSTEM PRESSURISATION.
- HANDLING OF NON AGGRESSIVE CIVIL AND INDUSTRIAL LIQUIDS.
- FOR WASHING SYSTEMS AND FOR INSERTION INTO COMPLEX INDUSTRIAL MACHINERY AND LINES.

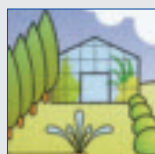

**AV ARVEN**

**CARATTERISTICHE DI COSTRUZIONE**

- MOTORE CHIUSO CON VENTILAZIONE ESTERNA E CASSA ALETTATA IN LEGA DI ALLUMINIO.
- GRADO DI PROTEZIONE IP 44.
- CLASSE DI ISOLAMENTO: F.
- TEMPERATURA MAX.LIQUIDO POMPATO: 35°C.
- VERSIONI: Monofase: 220-230V/50Hz o 220-230V/60Hz con protettore termico incorporato e condensatore permanentemente inserito.  
Trifase: 220-230V/50Hz e 380-400V/50Hz o 220-230V/60Hz e 380- 400V/60Hz con protezione da sovraccarico a cura dell'utente.
- POTENZA MOTORE: DA 0,5 Hp a 1,0 Hp SOLO VERSIONE MONOFASE.  
DA 1,5 Hp a 2,0 Hp VERSIONE MONOFASE E TRIFASE.

SPECIALI VOLTAGGI E FREQUENZE A RICHIESTA.

**APPLICATIONS DESIGN ENGINEERING**

- SEALED MOTOR WITH EXTERNAL VENTILATION AND FINNED ALUMINIUM ALLOY CASING.
- IP 44 PROTECTION CLASS.
- CLASS "F" INSULATION.
- MAX. PUMPED LIQUID TEMPERATURE: 35°C.
- VERSIONS: Single Phase: 220-230V/50Hz or 220-230V/60Hz with built in thermal protector and permanent capacitor.  
Three Phase: 220-230V/50Hz and 380-400V/50Hz or 220-230V/60Hz and 380-400V/60Hz with overload protection care of the User.
- MOTOR POWER: From 0.5 Hp to 1.0 Hp only single phase versions.  
From 1.5 Hp to 2.0 Hp single phase versions and three phases versions.

CUSTOMISED VOLTAGE AND FREQUENCY RATING AVAILABLE ON DEMAND.

**TABELLA MATERIALI / MATERIALS TABLE:**

Pos.	Componente / Component	Materiale / Materials
A	Corpo pompa / Pump body	GHISA / CAST IRON
B	Girante / Impeller	OTTONE / BRASS
C	Tenuta meccanica / Mechanical Seal	CERAMICA-GRAFITE / CERAMIC-GRAPHITE
D	Flangia / Flange	GHISA / CAST IRON
E	Albero (lato pompa) / Shaft (pump face)	ACCIAIO INOX / STAINLESS STEEL

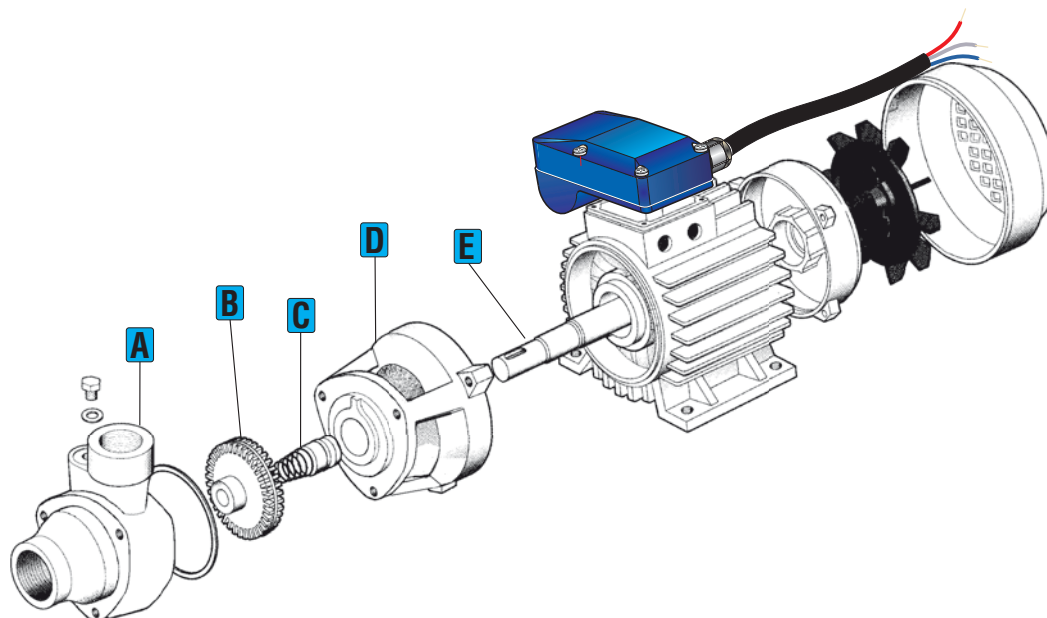

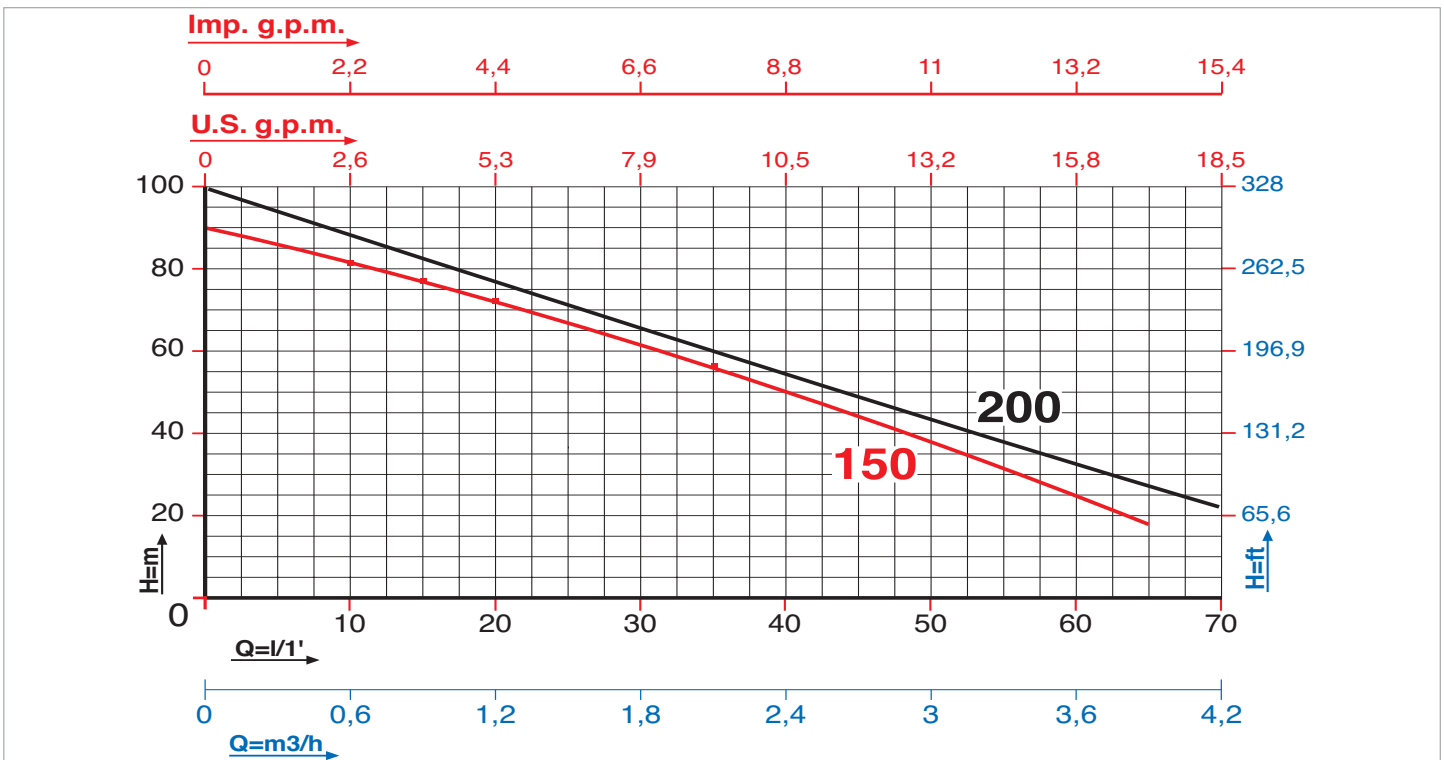
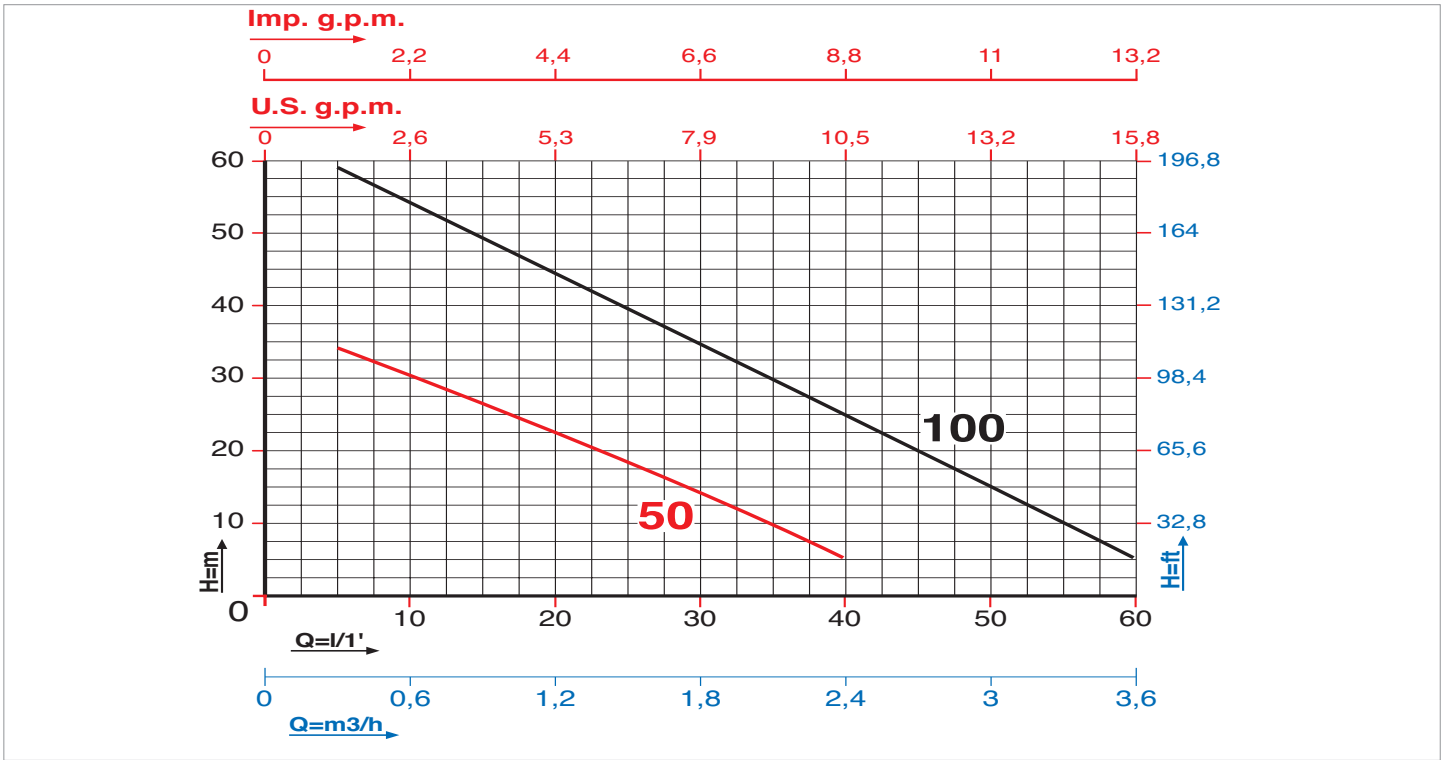

Caratteristiche di funzionamento a 2800 rpm 50Hz e 3450 rpm 60Hz - Performances at 2800 rpm 50 Hz and 3450 rpm 60 Hz  
 Le prestazioni valgono per liquidi con densità  $\rho = 1,0 \text{ kg/dm}^3$  ed una viscosità  $\nu = 1 \text{ mm}^2/\text{s}$  / The performance data holds true for liquids with a  $\rho = 1,0 \text{ kg/dm}^3$  density and a  $\nu = 1 \text{ mm}^2/\text{s}$  viscosity.

MODELLO MODEL	VOLTAGGIO VOLTAGE	DATI ELETTRICI / ELECTRICAL DATA						DATI IDRAULICI / HYDRAULIC DATA										
		P1 max		P2 nom.		I max	Condensatore Capacitor		m³/h									
		kW	kW	HP	Ampere		µF	VC	0,3	0,6	1,2	1,5	1,8	2,4	3,0	3,6	3,9	4,2
PMF 50 M	1 x 220-230V	0,55	0,37	0,5	2,9	10,0	450	H (m)	5	10	20	25	30	40	50	60	65	70
PMF 100 M	1 x 220-230V	0,9	0,75	1,0	3,8	16,0	450		34,0	30,0	22,0	17,0	13,0	5,0	---	---	---	---
PMF 150 M	1 x 220-230V	1,1	1,1	1,5	10,0	35,0	450		59,0	55,0	45,0	40,0	35,0	25,0	15,0	5,0	---	---
PMF 150 T	3 x 380-440V	1,1	1,1	1,5	3,6	---	---		83,0	81,0	72,0	67,0	61,5	50,0	38,0	22,0	18,0	---
PMF 200 M	1 x 220-230V	1,5	1,5	2,0	10,9	40,0	450		83,0	81,0	72,0	67,0	61,5	50,0	38,0	22,0	18,0	---
PMF 200 T	3 x 380-440V	1,5	1,5	2,0	4,0	---	---		93,0	88,0	77,0	71,5	62,5	57,0	43,5	37,5	27,5	22,0

PREVALENZA TOTALE in METRI COLONNA ACQUA / TOTAL PUMP HEAD AND WATER COLUMN HEIGHT IN m.

**DIMENSIONI e PESI / SIZE AND WEIGHT DATA :**

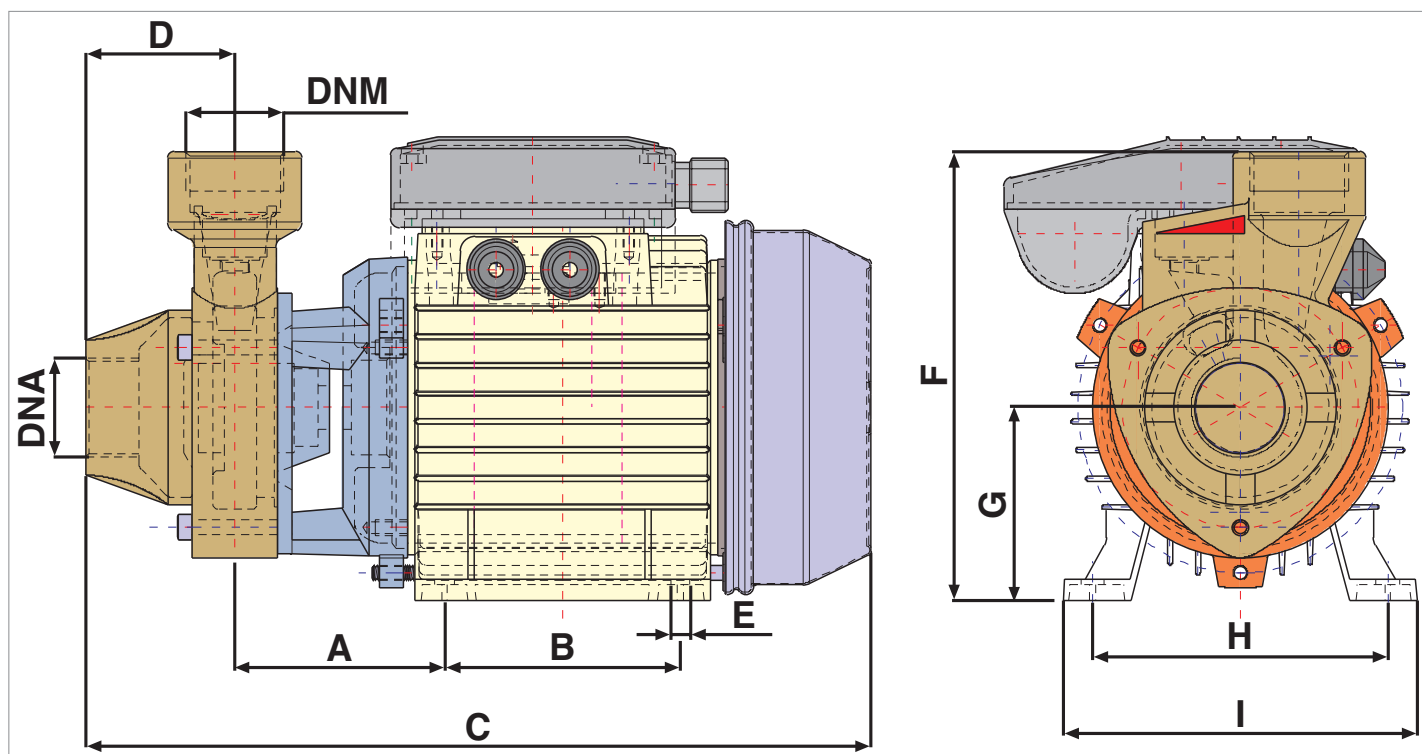
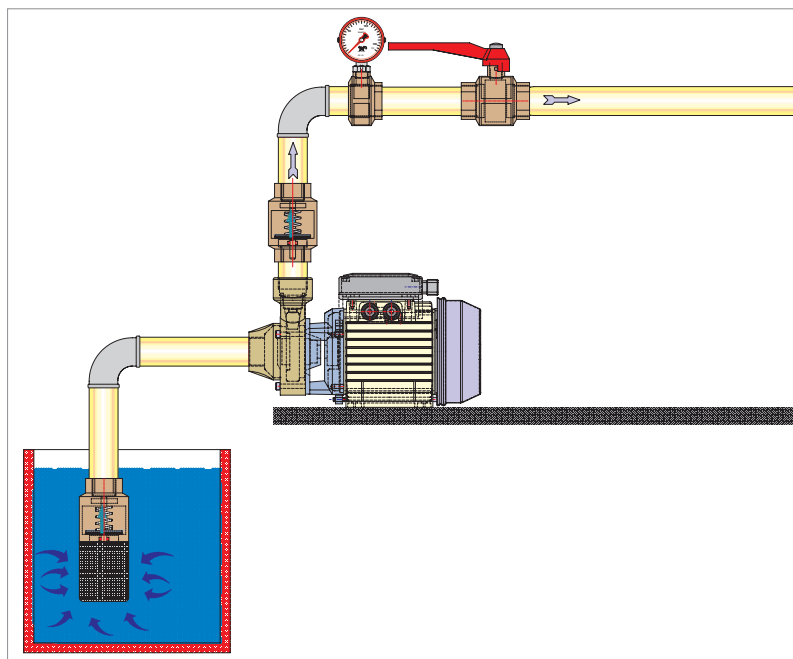
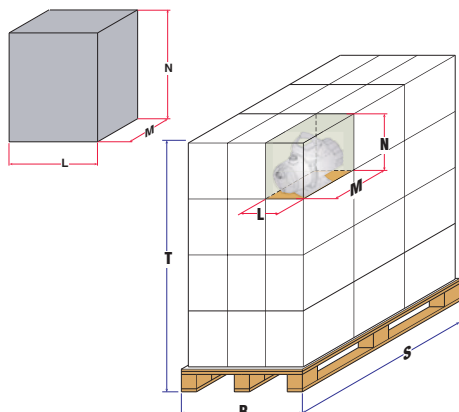

MODELLO / MODEL	DIMENSIONI POMPA in mm. / PUMP DIMENSIONS in mm.										
	DNA	DNM	A	B	C	D	E	F	G	H	I
PMF 50	1"	1"	65	80	255	20	7	144	63	100	120
PMF 100	1"	1"	70	90	295	20	7	161	71	112	135
PMF 150	1"	1"	88	100	330,5	57	9	212	80	125	152
PMF 200	1"	1"	88	100	330,5	57	9	212	80	125	152

MODELLO MODEL	DIMENSIONI SCATOLA / PACKING DIMENSIONS			
	L mm	M mm	N mm	Peso / Weight Kg
PMF 50	170	285	170	6,5
PMF 100	175	325	190	9,2
PMF 150	210	385	255	14,5
PMF 200	210	385	255	15,8



# JET



## **ELETTROPOMPE AUTOADESCANTI CON UNA GIRANTE SELF-PRIMING ELECTRIC PUMPS WITH ONE IMPELLER**

**PREVALENZA** ..... : 38 mt. ÷ 47 mt.  
**PORTATA** ..... : 3,6 m<sup>3</sup>/h - 9 m<sup>3</sup>/h  
**POTENZA NOMINALE** : 0,6 kW (0,8HP) ÷ 1,5 kW (2HP)

**PUMP HEAD** ..... : 38,0 mt ÷ 47,0 mt  
**DELIVERY** ..... : 3,6 m<sup>3</sup>/h ÷ 9,0 m<sup>3</sup>/h  
**RATED HORSEPOWER** : 0,6 kW (0,8HP) ÷ 1,5 kW (2,0HP)

### **APPLICAZIONI**

- PRESSURIZZAZIONE DI IMPIANTI DOMESTICI E PICCOLA IRRIGAZIONE.
- MOVIMENTAZIONE DI LIQUIDI NON AGGRESSIVI PER USI CIVILI ED INDUSTRIALI.
- IMPIANTI DI LAVAGGIO, INSERIMENTO SU MACCHINARI PIU' COMPLESSI PER USI INDUSTRIALI.
- IMPIANTI DOVE E' NECESSARIO L'AUTOADESCAMENTO.

### **APPLICATIONS**

- FOR DOMESTIC SYSTEMS AND SMALL IRRIGATION SYSTEM PRESSURISATION.
- HANDLING OF NON AGGRESSIVE CIVIL AND INDUSTRIAL LIQUIDS.
- FOR WASHING SYSTEMS AND FOR INSERTION INTO COMPLEX INDUSTRIAL MACHINERY AND LINES.
- FOR ANY APPLICATION REQUIRING A SELF PRIMING SYSTEM.

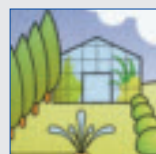
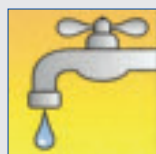

**AV ARVEN**

**CARATTERISTICHE DI COSTRUZIONE**

- MOTORE CHIUSO CON VENTILAZIONE ESTERNA E CASSA ALETTATA IN LEGA DI ALLUMINIO
- GRADO DI PROTEZIONE IP 44.
- CLASSE DI ISOLAMENTO: F.
- TEMPERATURA MAX.LIQUIDO POMPATO: 35°C.
- VERSIONI: Monofase: 220 - 230V/50Hz o 220 - 230V/60Hz con protettore termico incorporato e condensatore permanentemente inserito.  
Trifase: 220 - 230V/50Hz e 380 - 400V/50Hz o 220 - 230V/60Hz e 380 - 400V/60Hz con protezione da sovraccarico a cura dell'utente
- POTENZA MOTORE: DA 0,8 Hp a 2 Hp VERSIONE MONOFASE E TRIFASE.

SPECIALI VOLTAGGI E FREQUENZE A RICHIESTA.

**DESIGN ENGINEERING**

- SEALED MOTOR WITH EXTERNAL VENTILATION AND FINNED ALUMINIUM ALLOY CASING.
- IP 44 PROTECTION CLASS.
- CLASS "F" INSULATION.
- MAX. PUMPED LIQUID TEMPERATURE: 35°C.
- VERSIONS: Single Phase: 220 - 230 V/50 Hz or 220 - 230V/60 Hz with built in thermal protection and permanent capacitor.  
Three Phase : 220 - 230V/50Hz and 380 - 400V/50Hz or 220 - 230V/60Hz and 380- 400V/60Hz with overload protection care of the User.
- MOTOR POWER: From 0.8 Hp to 2 Hp single phase and three phases versions.

CUSTOMISED VOLTAGE AND FREQUENCY RATING AVAILABLE ON DEMAND.

**TABELLA MATERIALI / MATERIALS TABLE:**

Pos.	Componente / Component	Materiale / Materials	
A	Corpo pompa / Pump body	GHISA / CAST IRON	
B	Diffusore / Diffuser	NORYL	
C	Girante / Impeller	JET 90-100	NORYL
		JET 150-200	OTTONE / BRASS
D	Tenuta meccanica / Mechanical Seal	CERAMICA-GRAFITE / CERAMIC-GRAPHITE	
E	Flangia / Flange	JET 90-100	ALLUMINIO / ALUMINIUM
		JET 150-200	GHISA / CAST IRON
F	Albero (lato pompa) / Shaft (pump face)	ACCIAIO INOX / STAINLESS STEEL	

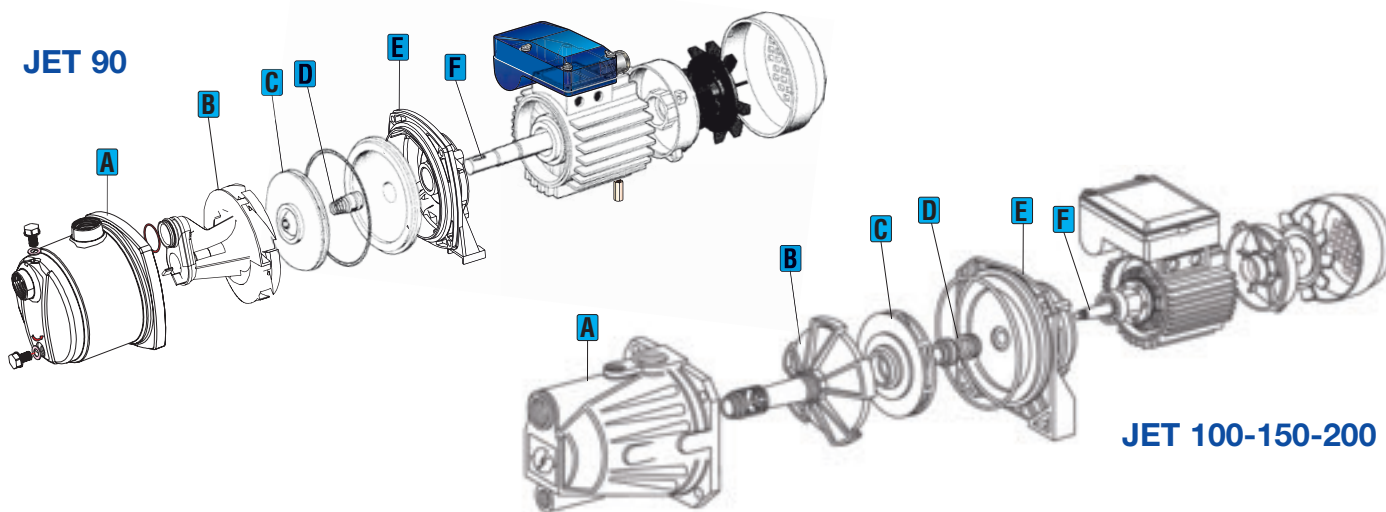

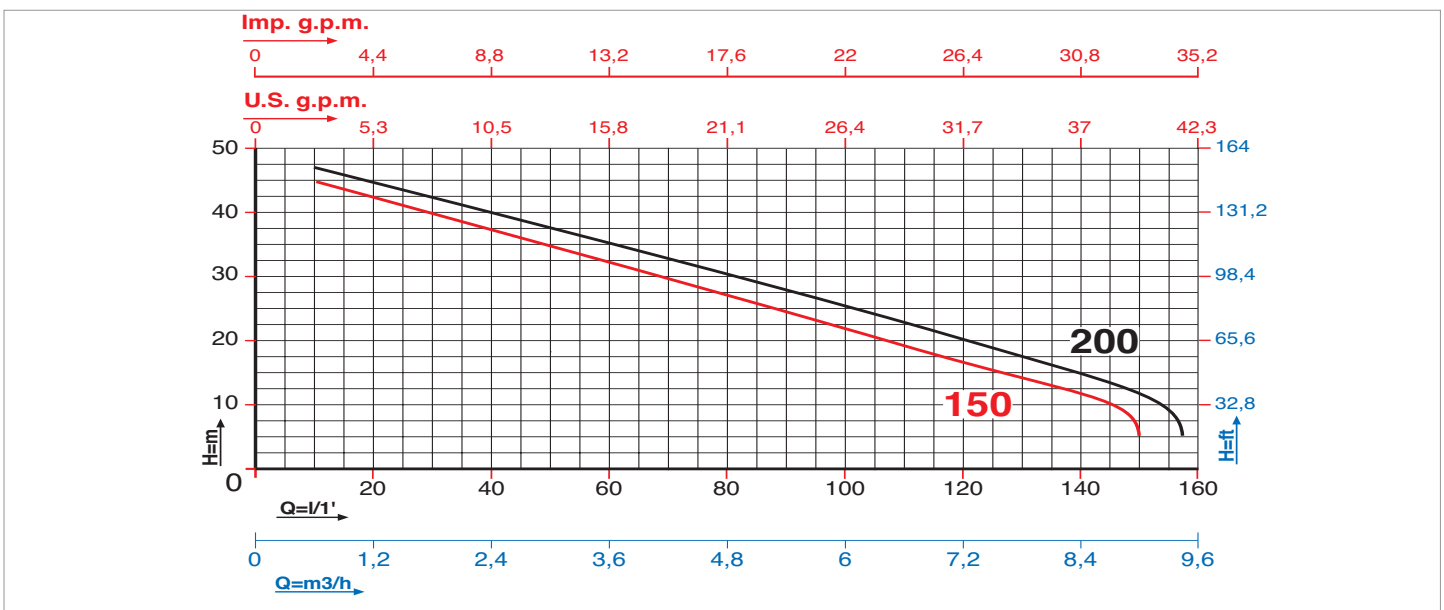
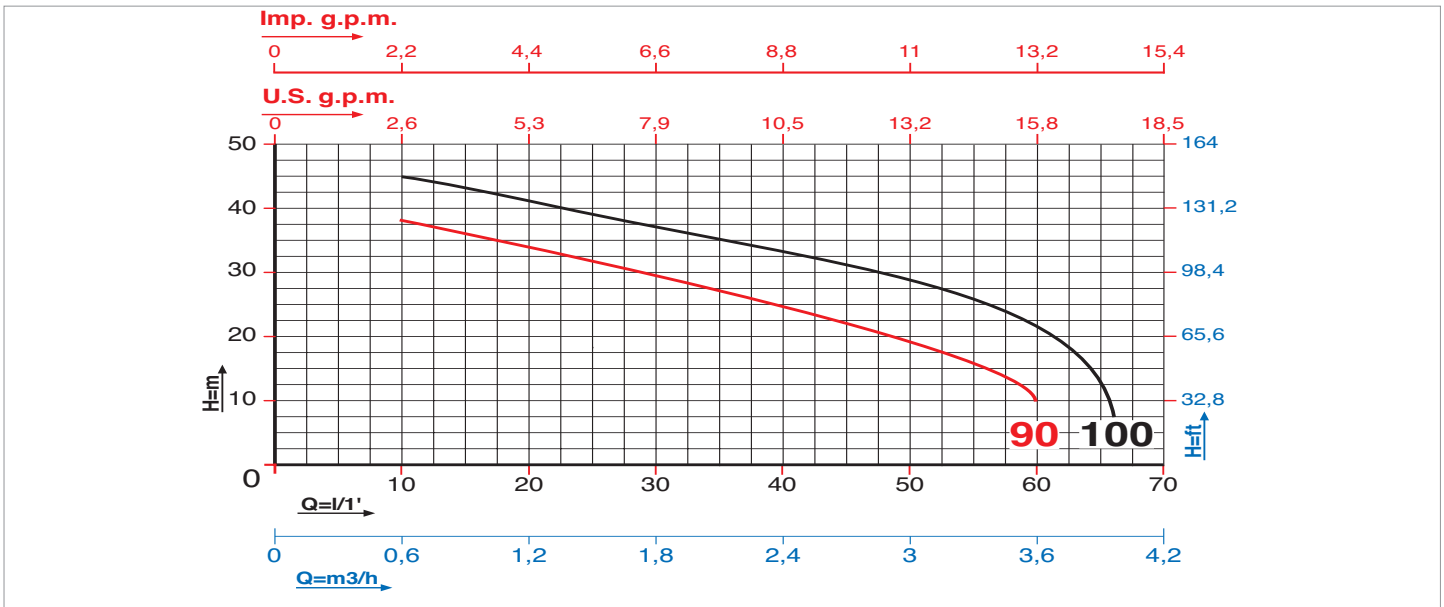

Caratteristiche di funzionamento a 2800 rpm 50Hz e 3450 rpm 60Hz - Performances at 2800 rpm 50 Hz and 3450 rpm 60 Hz  
 Le prestazioni valgono per liquidi con densità  $\rho = 1,0 \text{ kg/dm}^3$  ed una viscosità  $\nu = 1 \text{ mm}^2/\text{s}$  / The performance data holds true for liquids with a  $\rho = 1,0 \text{ kg/dm}^3$  density and a  $\nu = 1 \text{ mm}^2/\text{s}$  viscosity.

MODELLO MODEL	VOLTAGGIO VOLTAGE	DATI ELETTRICI / ELECTRICAL DATA						DATI IDRAULICI / HYDRAULIC DATA										
		P1max	P2 nom.		I max	Condensatore Capacitor		m³/h	0,6	1,2	1,8	2,4	3	3,6	4	5,4	6	9
50 Hz		kW	kW	HP	Ampere	µF	VC	l/min.	10	20	30	40	50	60	66	90	100	150
JET 90 M	1 x 220-230V	0,8	0,6	0,8	3,8	12,5	450	H (m)	38,0	34,0	29,0	25,0	19,0	10,0	---	---	---	---
JET 90 T	3 x 380-440V	0,8	0,6	0,8	1,9	---	---		38,0	34,0	29,0	25,0	19,0	10,0	---	---	---	---
JET 100 M	1 x 220-230V	1,1	0,75	1,0	5,0	20,0	450		45,0	40,0	35,0	30,0	26,0	22,0	7,0	---	---	---
JET 100 T	3 x 380-440V	1,1	0,75	1,0	2,5	---	---		45,0	40,0	35,0	30,0	26,0	22,0	7,0	---	---	---
JET 150 M	1 x 220-230V	1,5	1,1	1,5	7,0	40,0	450		45,0	42,0	40,0	37,5	34,5	33,0	30,5	25,0	22,0	10,0
JET 150 T	3 x 380-440V	1,5	1,1	1,5	3,0	---	---		45,0	42,0	40,0	37,5	34,5	33,0	30,5	25,0	22,0	10,0
JET 200 M	1 x 220-230V	2,0	1,5	2,0	9,3	40,0	450		47,0	45,0	43,0	40,0	37,5	35,0	33,0	27,0	18,0	13,0
JET 200 T	3 x 380-440V	2,0	1,5	2,0	4,2	---	---		47,0	45,0	43,0	40,0	37,5	35,0	33,0	27,0	18,0	13,0

PREVALENZA TOTALE in METRI COLONNA ACQUA / TOTAL PUMP HEAD AND WATER COLUMN HEIGHT IN m.

**DIMENSIONI e PESI / SIZE AND WEIGHT DATA:**

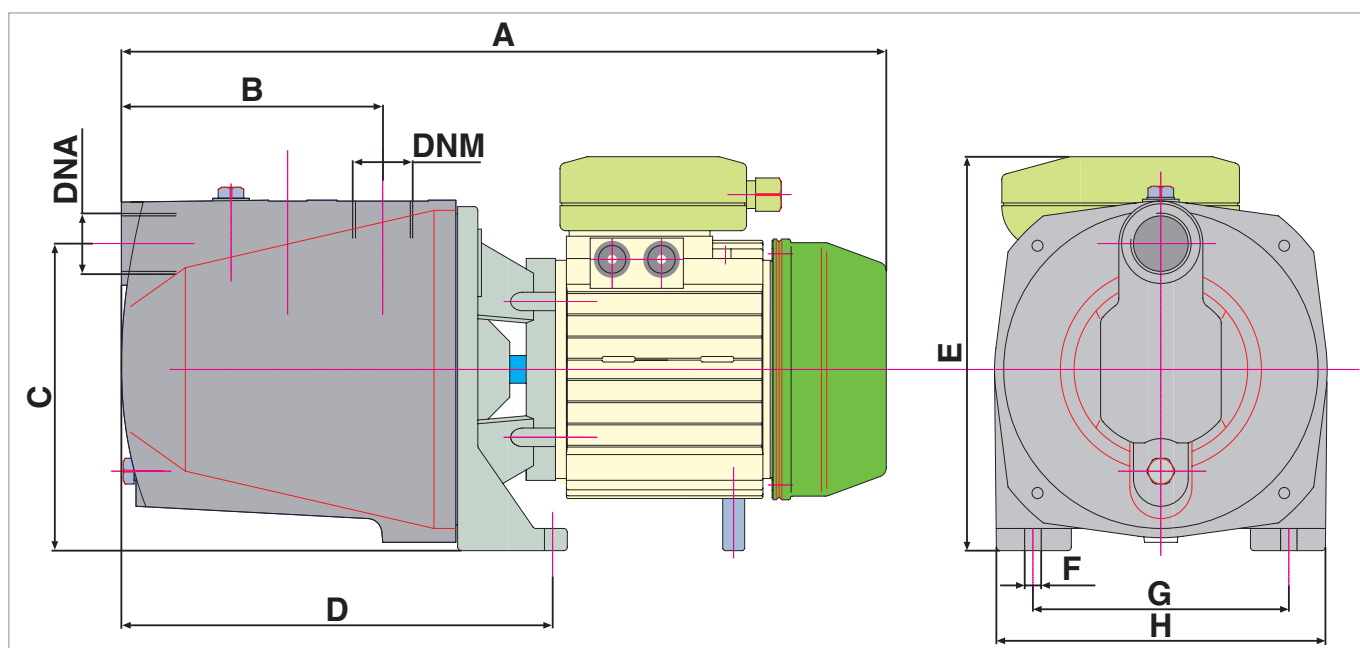
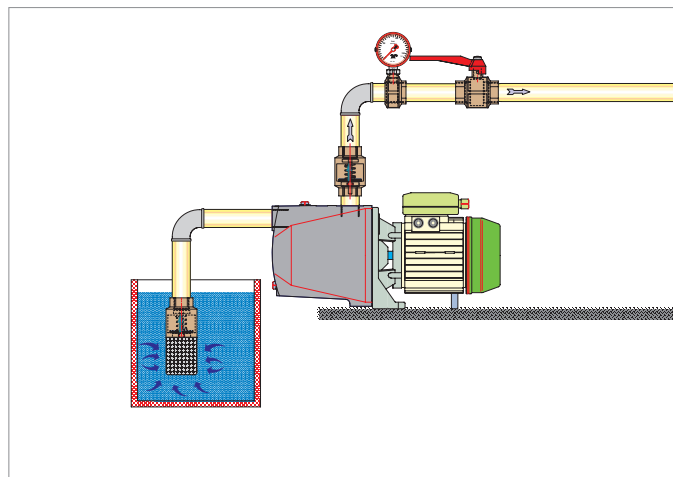
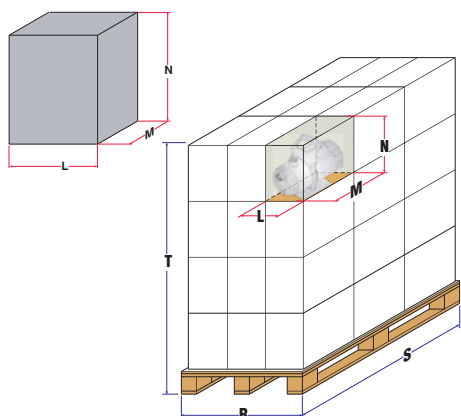

MODELLO / MODEL	DIMENSIONI POMPA in mm. / PUMP DIMENSIONS in mm.									
	DNA	DNM	A	B	C	D	E	F	G	H
JET 90	1"	1"	328	77	123	150	193	9	126	162
JET 100	1"	1"	421	145	156	211	194	9	140	176
JET 150	1" 1/4	1"	570	171	198	282	271	12	198	236
JET 200	1" 1/4	1"	570	171	198	282	271	12	198	236

MODELLO MODEL	DIMENSIONI SCATOLA / PACKING DIMENSIONS			
	L mm	M mm	N mm	Peso / Weight Kg
JET 90	350	180	200	9,0
JET 100	450	200	210	15,0
JET 150	590	255	280	38,0
JET 200	590	255	280	40,0

# JETX



## **ELETTROPOMPE AUTOADESCANTI CON UNA GIRANTE SELF-PRIMING ELECTRIC PUMPS WITH ONE IMPELLER**

**PREVALENZA** ..... : 36 mt. ÷ 61 mt.  
**PORTATA** ..... : 3 m<sup>3</sup>/h - 3,6 m<sup>3</sup>/h  
**POTENZA NOMINALE** : 0,5 Kw (0,7HP) ÷ 0,9 Kw (2,2HP)

**PUMP HEAD** ..... : 36,0 mt ÷ 61,0 mt  
**DELIVERY** ..... : 3,0 m<sup>3</sup>/h ÷ 3,6 m<sup>3</sup>/h  
**RATED HORSEPOWER** : 0,5 kW (0,7HP) ÷ 0,9 kW (1,2HP)

### **APPLICAZIONI**

- PRESSURIZZAZIONE DI IMPIANTI DOMESTICI E PICCOLA IRRIGAZIONE.
- MOVIMENTAZIONE DI LIQUIDI NON AGGRESSIVI PER USI CIVILI ED INDUSTRIALI.
- IMPIANTI DI LAVAGGIO, INSERIMENTO SU MACCHINARI PIU' COMPLESSI PER USI INDUSTRIALI.
- IMPIANTI DOVE E' NECESSARIO L'AUTOADESCAMENTO.

### **APPLICATIONS**

- FOR DOMESTIC SYSTEMS AND SMALL IRRIGATION SYSTEM PRESSURISATION.
- HANDLING OF NON AGGRESSIVE CIVIL AND INDUSTRIAL LIQUIDS.
- FOR WASHING SYSTEMS AND FOR INSERTION INTO COMPLEX INDUSTRIAL MACHINERY AND LINES.
- FOR ANY APPLICATION REQUIRING A SELF PRIMING SYSTEM.

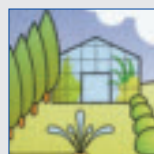
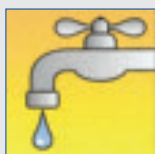
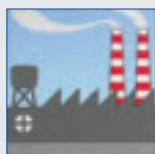

**AV ARVEN**

**CARATTERISTICHE DI COSTRUZIONE**

- MOTORE CHIUSO CON VENTILAZIONE ESTERNA E CASSA ALETTATA IN LEGA DI ALLUMINIO
- GRADO DI PROTEZIONE IP 44.
- CLASSE DI ISOLAMENTO: F
- TEMPERATURA MAX. LIQUIDO POMPATO: 35°C
- VERSIONI: Monofase: 220 - 230V/50Hz o 220 - 230V/60Hz con protettore termico incorporato e condensatore permanentemente inserito.  
Trifase: 220 - 230V/50Hz e 380 - 400V/50Hz o 220 - 230V/60Hz e 380 - 400V/60Hz con protezione da sovraccarico a cura dell'utente
- POTENZA MOTORE: 0,7 Hp solo VERSIONE MONOFASE.  
0,9 Hp a 1,2 Hp VERSIONE MONOFASE E TRIFASE

SPECIALI VOLTAGGI E FREQUENZE A RICHIESTA.

**DESIGN ENGINEERING**

- SEALED MOTOR WITH EXTERNAL VENTILATION AND FINNED ALUMINIUM ALLOY CASING.
- IP 44 PROTECTION CLASS.
- CLASS "F" INSULATION
- MAX. PUMPED LIQUID TEMPERATURE: 35°C
- VERSIONS: Single Phase: 220 - 230 V/50 Hz or 220 - 230V/60 Hz with built in thermal protection and permanent capacitor.  
Three Phase: 220 - 230V/50Hz and 380 - 400V/50Hz or 220 - 230V/60Hz and 380- 400V/60Hz with overload protection care of the User.
- MOTOR POWER: 0.7 Hp only single phase versions.  
0.9 Hp to 1,2Hp single phase and three phase version

CUSTOMISED VOLTAGE AND FREQUENCY RATING AVAILABLE ON DEMAND.

**TABELLA MATERIALI / MATERIALS TABLE:**

Pos.	Componente / Component	Materiale / Materials
A	Corpo pompa / Pump body	GHISA / CAST IRON
B	Diffusore / Diffuser	NORYL
C	Girante / Impeller	JETX 90 NORYL
		JET 100 ACCIAIO INOX / STAINLESS STEEL
D	Tenuta meccanica / Mechanical Seal	CERAMICA-GRAFITE / CERAMIC-GRAPHITE
E	Flangia / Flange	ALLUMINIO / ALUMINIUM
F	Albero (lato pompa) / Shaft (pump face)	ACCIAIO INOX / STAINLESS STEEL

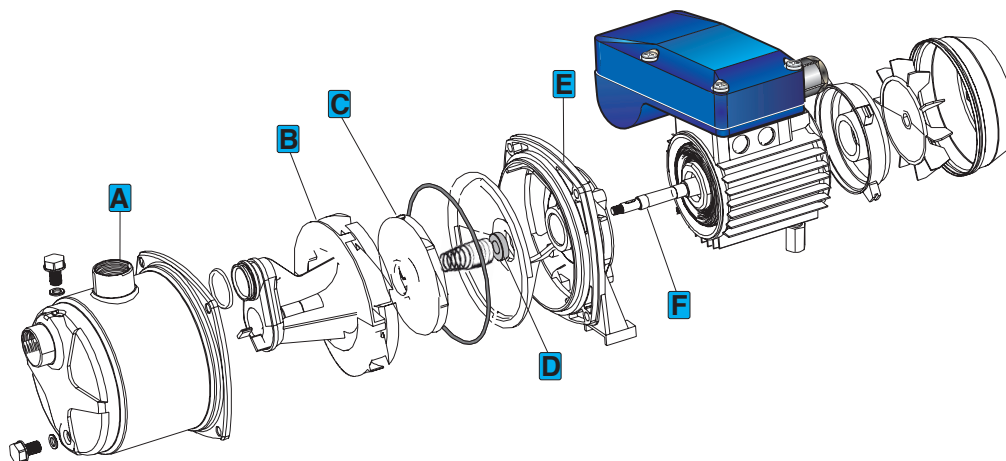



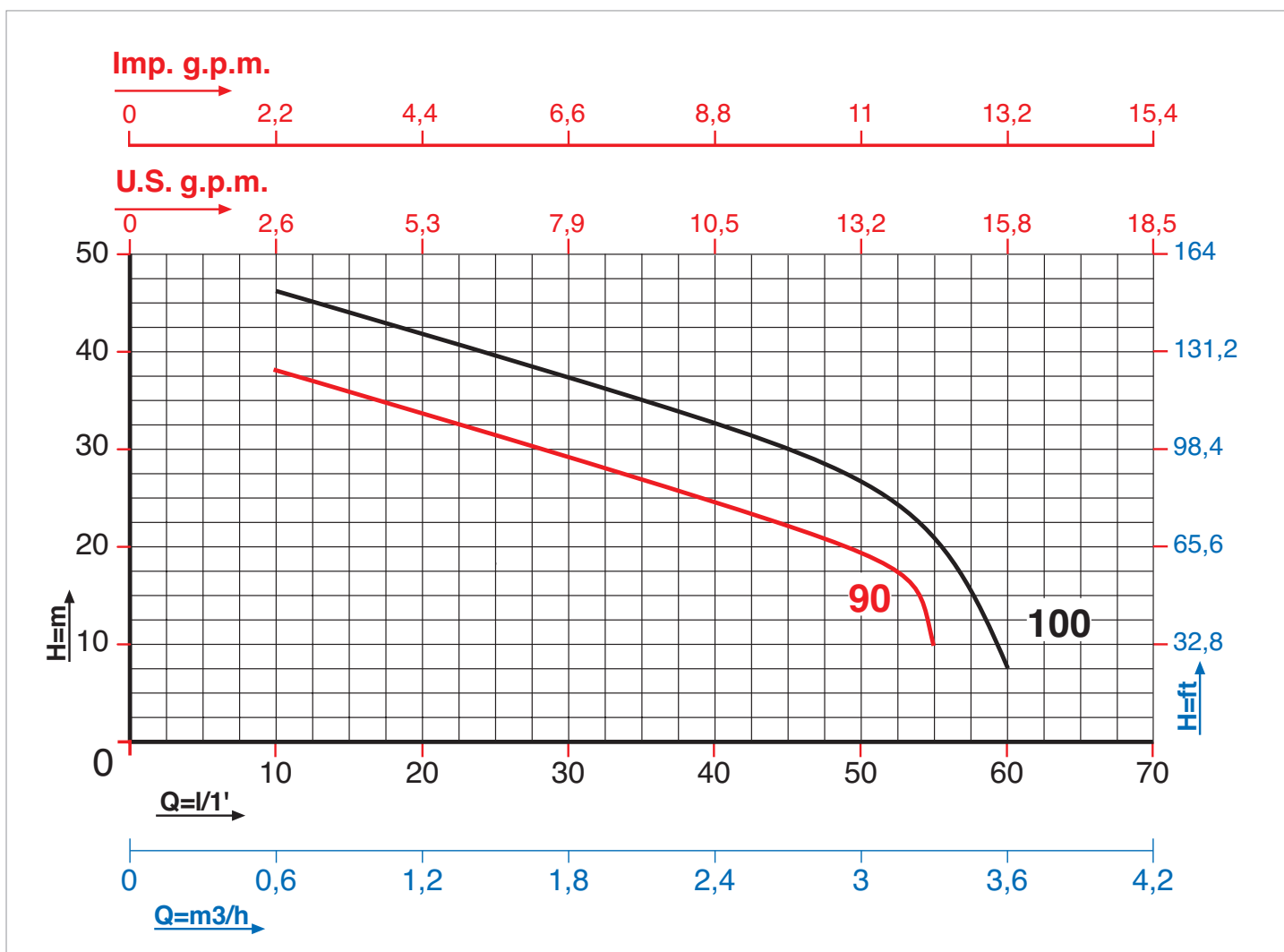

Caratteristiche di funzionamento a 2800 rpm 50Hz e 3450 rpm 60Hz - Performances at 2800 rpm 50 Hz and 3450 rpm 60 Hz  
 Le prestazioni valgono per liquidi con densità  $\rho = 1,0 \text{ kg/dm}^3$  ed una viscosità  $\nu = 1 \text{ mm}^2/\text{s}$  / The performance data holds true for liquids with a  $\rho = 1,0 \text{ kg/dm}^3$  density and a  $\nu = 1 \text{ mm}^2/\text{s}$  viscosity.

MODELLO MODEL	VOLTAGGIO VOLTAGE	DATI ELETTRICI / ELECTRICAL DATA						DATI IDRAULICI / HYDRAULIC DATA										
		P1 max kW	P2 nom. kW	HP	I max Ampere	Condensatore Capacitor		m³/h	0,6	0,9	1,2	1,5	1,8	2,1	2,4	3	3,3	3,6
						µF	VC	l/min.	10	15	20	25	30	35	40	50	55	60
JETX 90 M	1 x 220-230V	0,8	0,6	0,8	3,8	12,5	450	H (m)	38,0	36,0	34,0	32,0	29,0	27,0	24,0	19,0	10,0	---
JETX 90 T	3 x 380-440V	0,8	0,6	0,8	1,9	---	---		38,0	36,0	34,0	32,0	29,0	27,0	24,0	19,0	10,0	---
JETX 100 M	1 x 220-230V	1,1	0,75	1,0	4,0	20,0	450		46,0	43,0	40,0	38,0	35,0	32,0	30,0	26,0	20,5	10,0
JETX 100 T	3 x 380-440V	1,1	0,75	1,0	2,1	---	---		46,0	43,0	40,0	38,0	35,0	32,0	30,0	26,0	20,5	10,0

PREVALENZA TOTALE in METRI COLONNA ACQUA / TOTAL PUMP HEAD AND WATER COLUMN HEIGHT IN m.

**DIMENSIONI e PESI / SIZE AND WEIGHT DATA:**

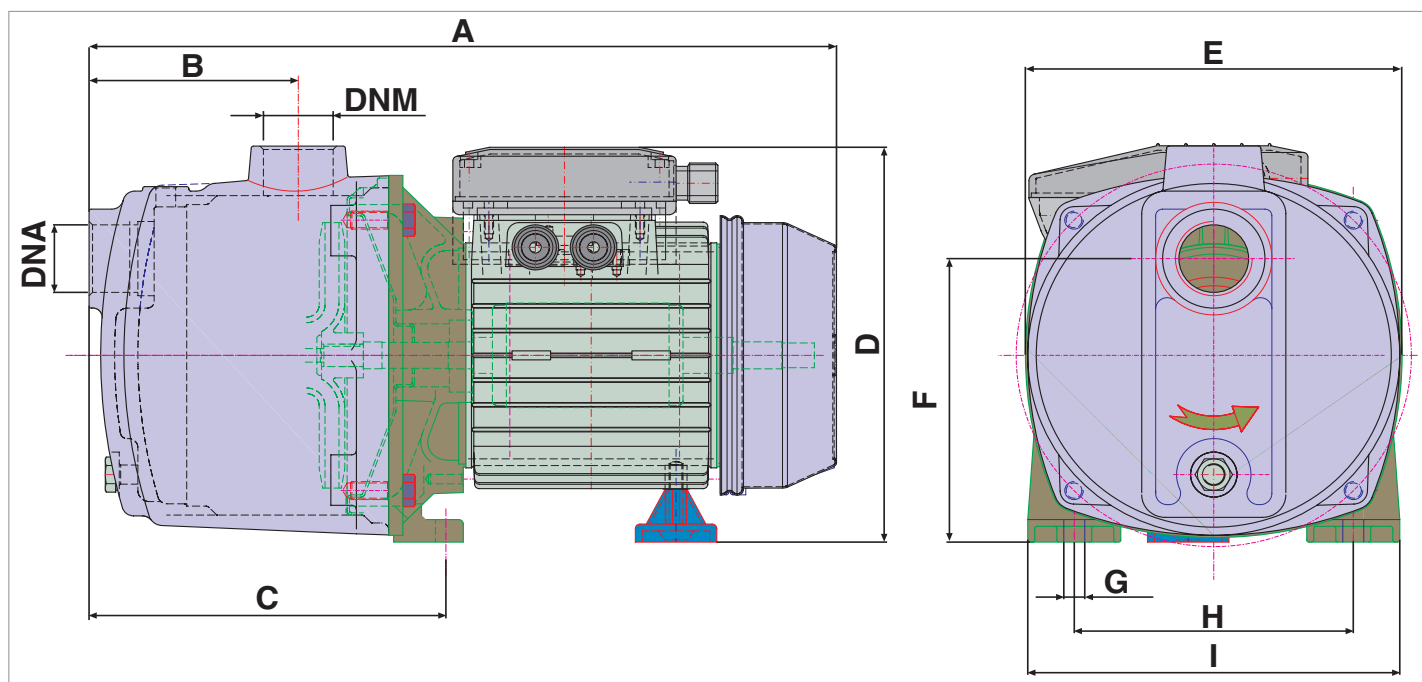
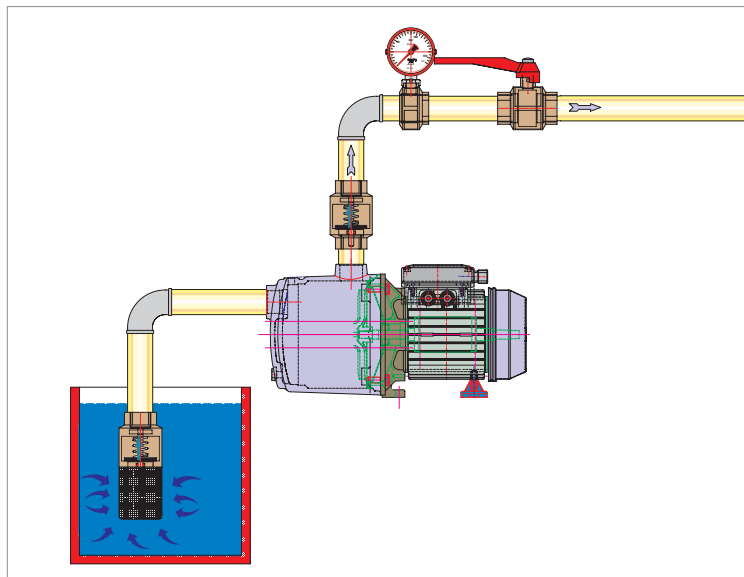
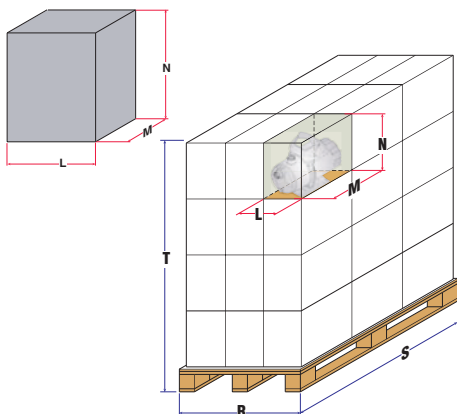

MODELLO / MODEL	DIMENSIONI POMPA in mm. / PUMP DIMENSIONS in mm.										
	DNA	DNM	A	B	C	D	E	F	G	H	I
JETX 90	1"	1"	320	72	163	180	166	123	9	126	162
JETX 100	1"	1"	370	81	163	200	184	149	9	140	176

MODELLO MODEL	DIMENSIONI SCATOLA / PACKING DIMENSIONS			
	L mm	M mm	N mm	Peso / Weight Kg
JETX 90	360	180	200	7,0
JETX 100	420	190	230	8,5

# R



## **ELETTROPOMPE CENTRIFUGHE CON UNA GIRANTE CENTRIFUGAL ELECTRIC PUMPS WITH ONE IMPELLER**

**PREVALENZA** ..... : 20 mt. ÷ 54 mt.  
**PORTATA** ..... : 6 m<sup>3</sup>/h ÷ 9 m<sup>3</sup>/h.  
**POTENZA NOMINALE** : 0,37 kW (0,5HP) ÷ 2,2 kW (3HP)

**PUMP HEAD** ..... : 20,0 mt ÷ 54,0 mt  
**DELIVERY** ..... : 6,0 m<sup>3</sup>/h ÷ 9,0 m<sup>3</sup>/h  
**RATED HORSEPOWER** : 0,37 kW (0,5HP) ÷ 2,2 kW (3,0HP)

### **APPLICAZIONI**

- PRESSURIZZAZIONE DI IMPIANTI DOMESTICI E PICCOLA IRRIGAZIONE
- MOVIMENTAZIONE DI LIQUIDI NON AGGRESSIVI PER USI CIVILI ED INDUSTRIALI
- IMPIANTI DI LAVAGGIO, INSERIMENTO SU MACCHINARI PIU' COMPLESSI PER USI INDUSTRIALI

### **APPLICATIONS**

- FOR DOMESTIC SYSTEMS AND SMALL IRRIGATION SYSTEM PRESSURISATION.
- HANDLING OF NON AGGRESSIVE CIVIL AND INDUSTRIAL LIQUIDS.
- FOR WASHING SYSTEMS AND FOR INSERTION INTO COMPLEX INDUSTRIAL MACHINERY AND LINES.

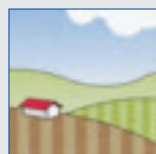
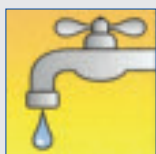

**AV ARVEN**

**CARATTERISTICHE DI COSTRUZIONE**

- MOTORE CHIUSO CON VENTILAZIONE ESTERNA E CASSA ALETTATA IN LEGA DI ALLUMINIO.
- GRADO DI PROTEZIONE IP 44 (R 50-75-100).
- GRADO DI PROTEZIONE IP 55 (R 150-200-300).
- CLASSE DI ISOLAMENTO: F.
- TEMPERATURA MAX.LIQUIDO POMPATO: 35°C.
- VERSIONI: Monofase: 220 - 230V/50Hz o 220 - 230V/60Hz con protettore termico incorporato e condensatore permanentemente inserito.  
Trifase: 220 - 230V/50Hz e 380 - 400V/50Hz o 220 - 230V/60Hz e 380-400V/60Hz con protezione da sovraccarico a cura dell'utente.
- POTENZA MOTORE: da 0,5 Hp ÷ 3 Hp VERSIONE MONOFASE E TRIFASE.

SPECIALI VOLTAGGI E FREQUENZE A RICHIESTA.

**DESIGN ENGINEERING**

- SEALED MOTOR WITH EXTERNAL VENTILATION AND FINNED ALUMINIUM ALLOY CASING.
- IP 44 PROTECTION CLASS (R 50-75-100).
- IP 55 PROTECTION CLASS (R 150-200-300).
- CLASS "F" INSULATION.
- MAX. PUMPED LIQUID TEMPERATURE: 35°C.
- VERSIONS: Single Phase: 220 - 230 V/50 Hz or 220 - 230V/60 Hz with built in thermal protection and permanent capacitor.  
Three Phase: 220 - 230V/50Hz and 380 - 400V/50Hz or 220 - 230V/60Hz and 380- 400V/60Hz with overload protection care of the User.
- MOTOR POWER: From 0.5 Hp to 3 Hp single phase and three phase versions.

CUSTOMISED VOLTAGE AND FREQUENCY RATING AVAILABLE ON DEMAND.

**TABELLA MATERIALI / MATERIALS TABLE:**

Pos.	Componente / Component		Materiale / Materials
A	Corpo pompa / Pump body		GHISA / CAST IRON
B	Girante / Impeller	R 50-75-100 R 150-200-300	NORYL OTTONE / BRASS
C	Tenuta meccanica / Mechanical Seal		CERAMICA-GRAFITE / CERAMIC-GRAPHITE
D	Flangia / Flange	R 50-75-100	ALLUMINIO / ALUMINIUM
		R 150-200-300	GHISA / CAST IRON
E	Albero (lato pompa) / Shaft (pump face)		ACCIAIO INOX / STAINLESS STEEL

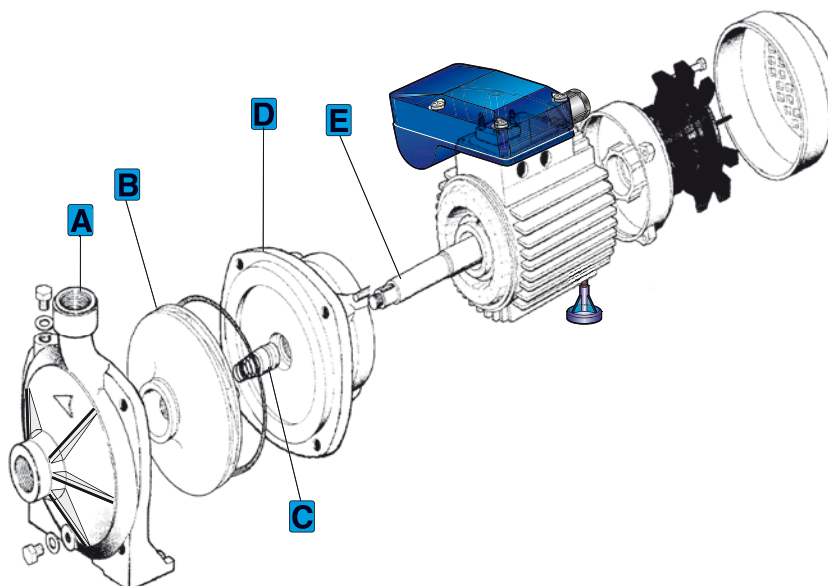

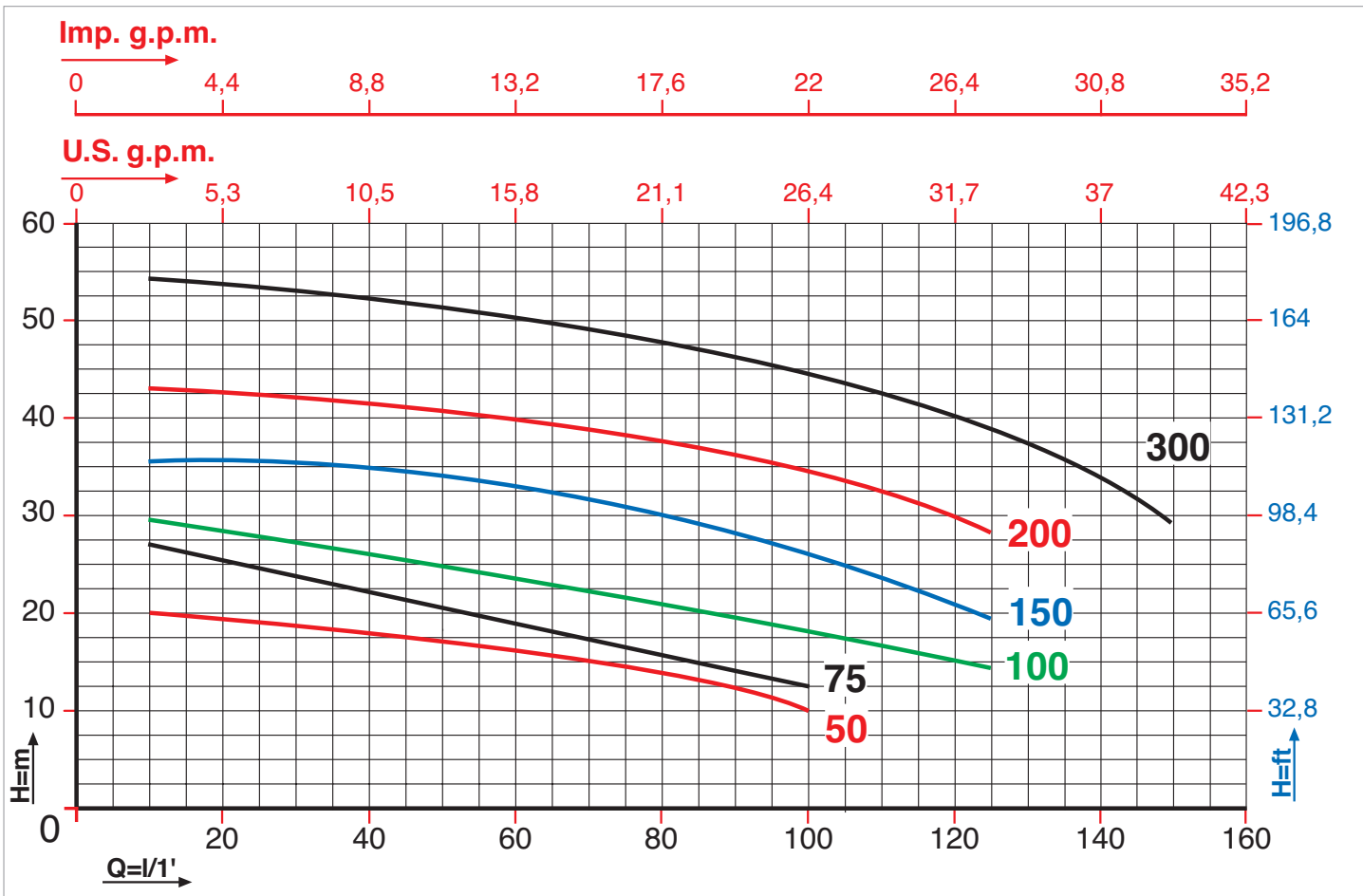

Caratteristiche di funzionamento a 2800 rpm 50Hz e 3450 rpm 60Hz - Performances at 2800 rpm 50 Hz and 3450 rpm 60 Hz  
 Le prestazioni valgono per liquidi con densità  $\rho = 1,0 \text{ kg/dm}^3$  ed una viscosità  $\nu = 1 \text{ mm}^2/\text{s}$  / The performance data holds true for liquids with a  $\rho = 1,0 \text{ kg/dm}^3$  density and a  $\nu = 1 \text{ mm}^2/\text{s}$  viscosity.

MODELLO MODEL	VOLTAGGIO VOLTAGE 50 Hz	DATI ELETTRICI / ELECTRICAL DATA						DATI IDRAULICI / HYDRAULIC DATA									PREVALENZA TOTALE IN METRI COLONNA ACQUA / TOTAL PUMP HEAD AND WATER COLUMN HEIGHT IN m.
		P1 max kW	P2 nom.		I max Ampere	Condensatore Capacitor		m³/h	0,6	1,2	2,4	3,6	4,8	6	7,5	9	
			kW	HP		µF	VC	l/min.	10	20	40	60	80	100	125	150	
R 50 M	1 x 220-230V	0,65	0,37	0,5	2,8	12,5	450	H (m)	20,0	18,0	17,5	16,0	13,5	10,0	---	---	
R 50 T	3 x 380-440V	0,65	0,37	0,5	1,2	---	---		20,0	18,0	17,5	16,0	13,5	10,0	---	---	
R 75 M	1 x 220-230V	0,9	0,55	0,75	4,0	12,5	450		27,0	25,0	22,5	18,0	15,0	12,0	---	---	
R 75 T	3 x 380-440V	0,9	0,55	0,75	1,7	---	---		27,0	25,0	22,5	18,0	15,0	12,0	---	---	
R 100 M	1 x 220-230V	1,2	0,75	1,0	5,5	20,0	450		29,0	28,0	26,0	23,0	21,0	18,0	14,0	---	
R 100 T	3 x 380-440V	1,2	0,75	1,0	2,3	---	---		29,0	28,0	26,0	23,0	21,0	18,0	14,0	---	
R 150 M	1 x 220-230V	1,75	1,1	1,5	8,0	32,0	450		36,0	35,5	34,5	33,5	30,0	26,0	19,0	---	
R 150 T	3 x 380-440V	1,75	1,1	1,5	4,0	---	---		36,0	35,5	34,5	33,5	30,0	26,0	19,0	---	
R 200 M	1 x 220-230V	2,4	1,5	2,0	10,5	35,0	450		43,0	42,0	41,5	40,5	37,5	34,0	28,0	---	
R 200 T	3 x 380-440V	2,4	1,5	2,0	5,0	---	---		43,0	42,0	41,5	40,5	37,5	34,0	28,0	---	
R 300 M	1 x 220-230V	3,3	2,2	3,0	15,0	60,0	450		54,0	53,0	52,5	51,0	47,5	45,0	38,0	29,0	
R 300 T	3 x 380-440V	3,3	2,2	3,0	5,5	---	---		54,0	53,0	52,5	51,0	47,5	45,0	38,0	29,0	

**DIMENSIONI e PESI / SIZE AND WEIGHT DATA:**

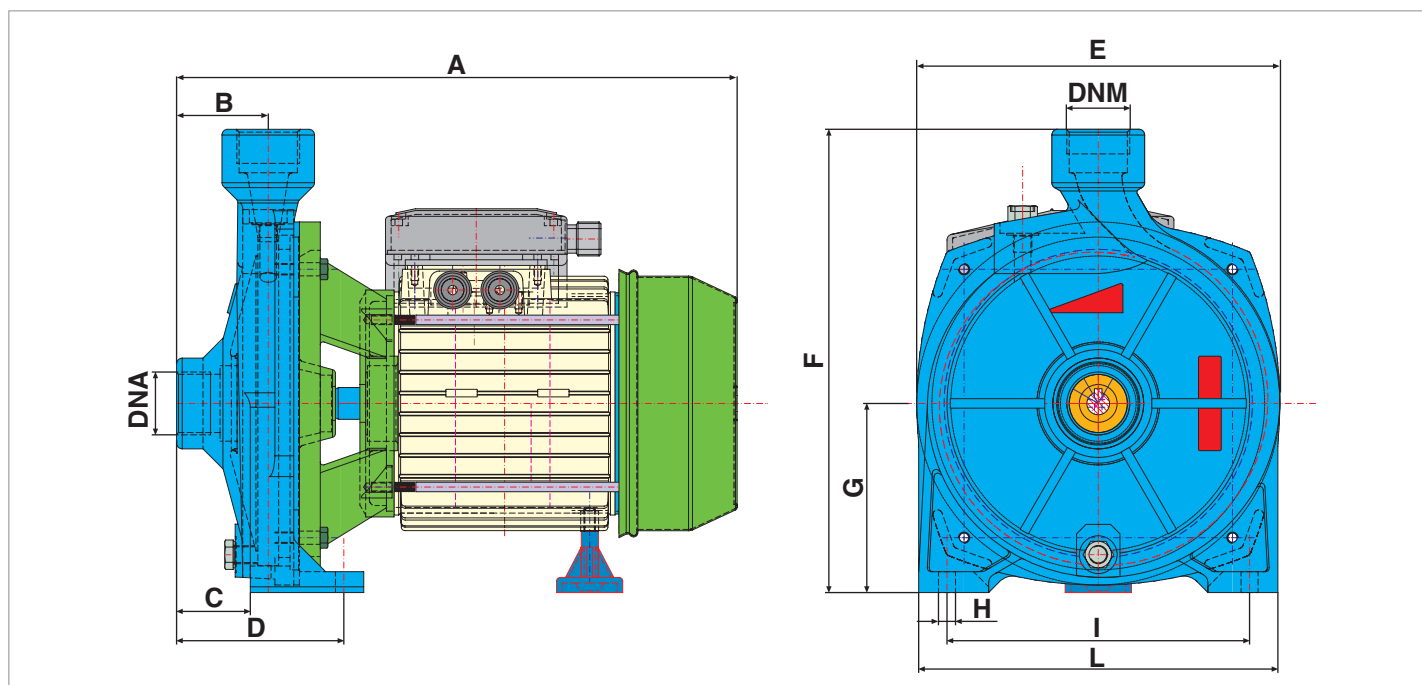
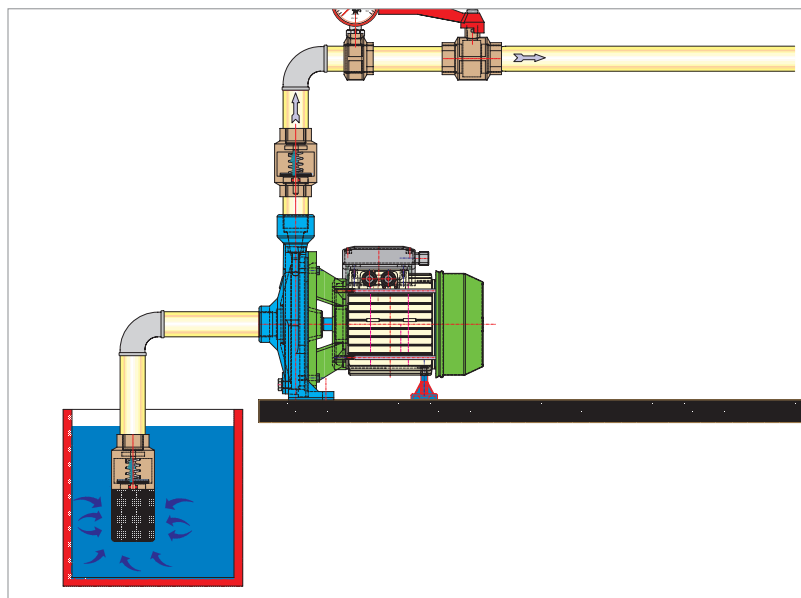
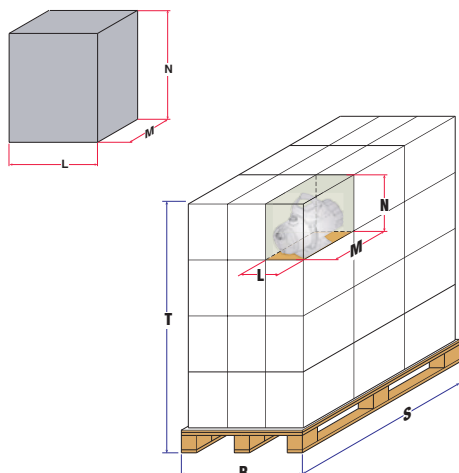

MODELLO / MODEL	DIMENSIONI POMPA in mm. / PUMP DIMENSIONS in mm.											
	DNA	DNM	A	B	C	D	E	F	G	H	I	L
R 50	1"	1"	260	47	90	100	164	205	83	9	126	162
R 75	1"	1"	300	50	98	108	186	229	94	9	140	176
R 100	1"	1"	300	50	98	108	186	229	94	9	140	176
R 150	1" 1/4	1"	355	48,5	45	76,5	224	305	125	12	147,5	220
R 200	1" 1/4	1"	410	48,5	45	76,5	224	305	125	12	147,5	220
R 300	1" 1/4	1"	410	48,5	45	76,5	224	305	125	12	147,5	220

MODELLO MODEL	DIMENSIONI SCATOLA / PACKING DIMENSIONS			
	L mm	M mm	N mm	Peso / Weight Kg
R 50	300	180	250	8,0
R 75	340	195	250	9,2
R 100	340	195	250	11,8
R 150	380	240	360	23,0
R 200	440	240	360	24,0
R 300	440	240	360	27,0



# RB



## **ELETTROPOMPE CENTRIFUGHE CON DUE GIRANTI CENTRIFUGAL ELECTRIC PUMPS WITH TWO IMPELLERS**

**PREVALENZA** ..... : 44 mt. ÷ 90 mt.  
**PORTATA** ..... : 3 m<sup>3</sup>/h ÷ 16,5 m<sup>3</sup>/h  
**POTENZA NOMINALE** : 0,75 kW (1HP) ÷ 5,5 kW (7,5HP)

**PUMP HEAD** ..... : 44,0 mt ÷ 90,0 mt  
**DELIVERY** ..... : 3,0m<sup>3</sup>/h ÷ 16,5 m<sup>3</sup>/h  
**RATED HORSEPOWER** : 0,75 kW (1,0HP) ÷ 5,5 kW (7,5HP)

### **APPLICAZIONI**

- PRESSURIZZAZIONE DI IMPIANTI DOMESTICI E PICCOLA IRRIGAZIONE.
- MOVIMENTAZIONE DI LIQUIDI NON AGGRESSIVI PER USI CIVILI ED INDUSTRIALI.
- IMPIANTI DI LAVAGGIO, INSERIMENTO SU MACCHINARI PIU' COMPLESSI PER USI INDUSTRIALI.

### **APPLICATIONS**

- FOR DOMESTIC SYSTEMS AND SMALL IRRIGATION SYSTEM PRESSURISATION.
- HANDLING OF NON AGGRESSIVE CIVIL AND INDUSTRIAL LIQUIDS.
- FOR WASHING SYSTEMS AND FOR INSERTION INTO COMPLEX INDUSTRIAL MACHINERY AND LINES.

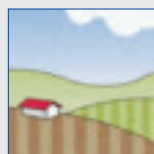
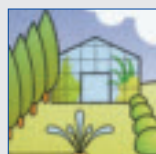
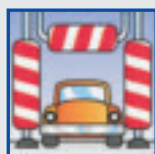

**AV ARVEN**

**CARATTERISTICHE DI COSTRUZIONE**

- MOTORE CHIUSO CON VENTILAZIONE ESTERNA E CASSA ALETTATA IN LEGA DI ALLUMINIO.
- GRADO DI PROTEZIONE IP 44.
- CLASSE DI ISOLAMENTO: F.
- TEMPERATURA MAX.LIQUIDO POMPATO: 35°C.
- VERSIONI: Monofase: 220 - 230V/50Hz o 220 - 230V/60Hz con protettore termico incorporato e condensatore permanentemente inserito.  
Trifase: 220 - 230V/50Hz e 380 - 400V/50Hz o 220 - 230V/60Hz e 380 - 400V/60Hz con protezione da sovraccarico a cura dell'utente.
- POTENZA MOTORE: 1 Hp solo VERSIONE MONOFASE.  
DA 1,5 Hp a 2 Hp VERSIONE MONOFASE E TRIFASE  
DA 3 Hp a 7,5 SOLO VERSIONE TRIFASE.

SPECIALI VOLTAGGI E FREQUENZE A RICHIESTA.

**DESIGN ENGINEERING**

- SEALED MOTOR WITH EXTERNAL VENTILATION AND FINNED ALUMINIUM ALLOY CASING.
  - IP 44 PROTECTION CLASS.
  - CLASS "F" INSULATION.
  - MAX. PUMPED LIQUID TEMPERATURE: 35°C.
  - VERSIONS: Single Phase: 220 - 230 V/50 Hz with built in thermal protection and permanent capacitor.  
Three Phase: 220 - 230V/50Hz or 380- 400V/50Hz and 220 - 230V/60Hz or 380 - 400V/60Hz with overload protection care of the User.
  - MOTOR POWER: 1 Hp only single phase versions.  
From 1.5 Hp to 2 Hp single phase and three phases versions  
From 3 Hp to 7,5 only Three Phases versions.
- CUSTOMISED VOLTAGE AND FREQUENCY RATING AVAILABLE ON DEMAND.

**TABELLA MATERIALI / MATERIALS TABLE:**

Pos.	Componente / Component	Materiale / Materials
A	Corpo pompa / Pump body	GHISA / CAST IRON
B	Girante / Impeller	OTTONE / BRASS
C	Tenuta meccanica / Mechanical Seal	CERAMICA-GRAFITE / CERAMIC-GRAPHITE
D	Flangia / Flange	GHISA / CAST IRON
E	Albero (lato pompa) / Shaft (pump face)	ACCIAIO INOX / STAINLESS STEEL

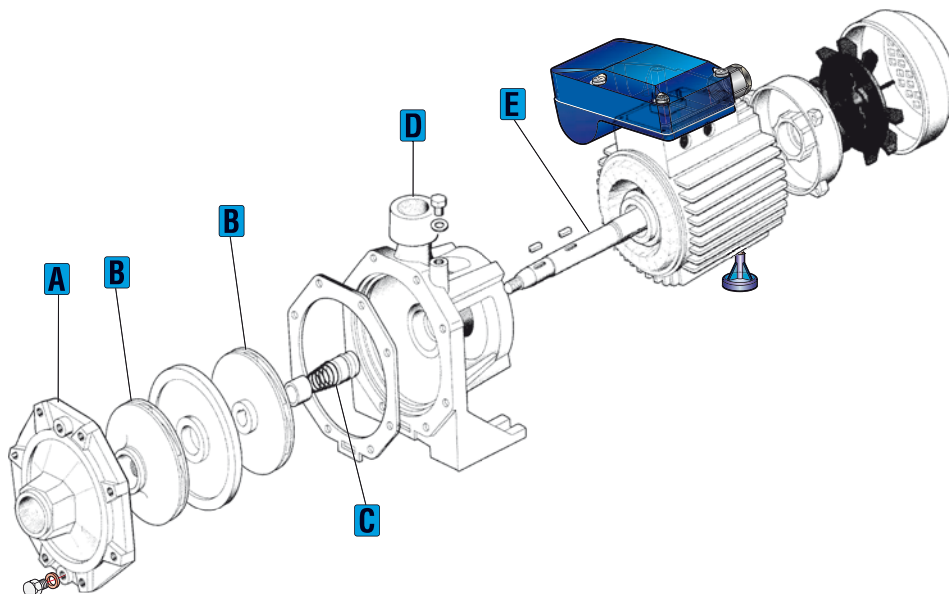

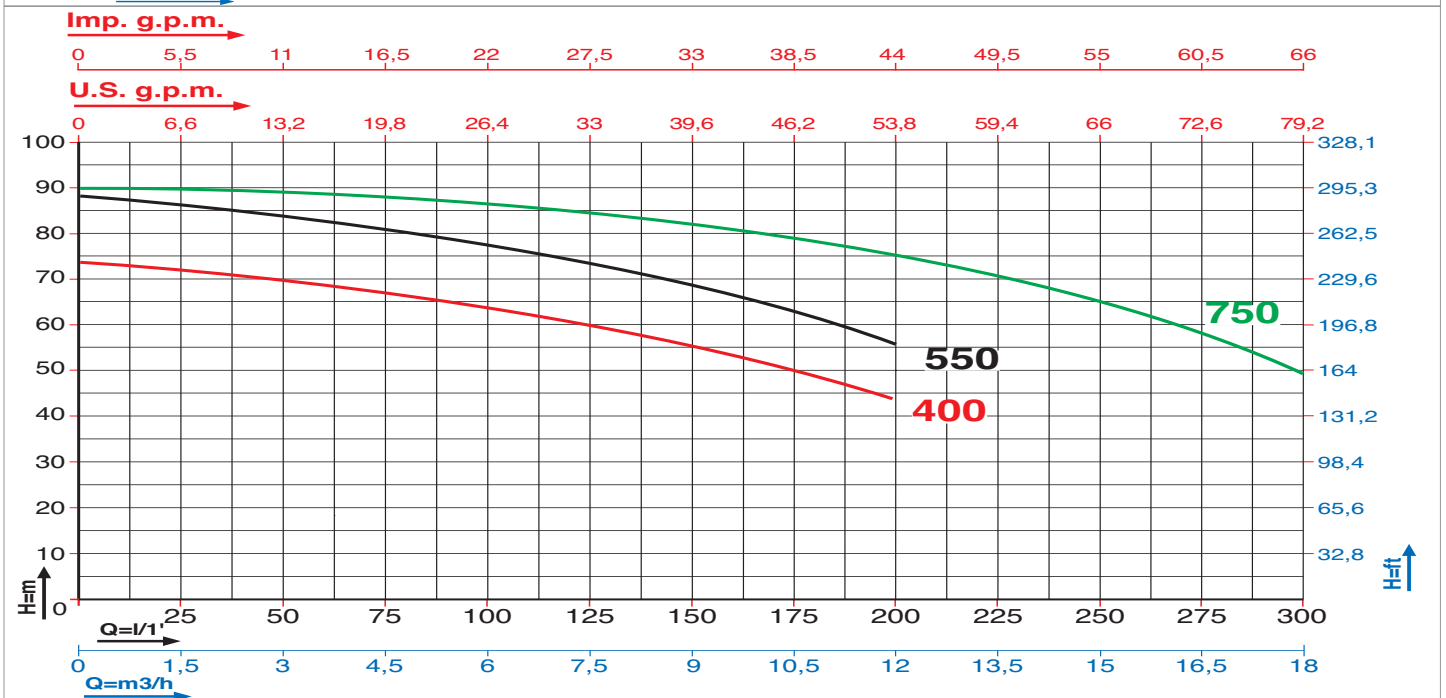
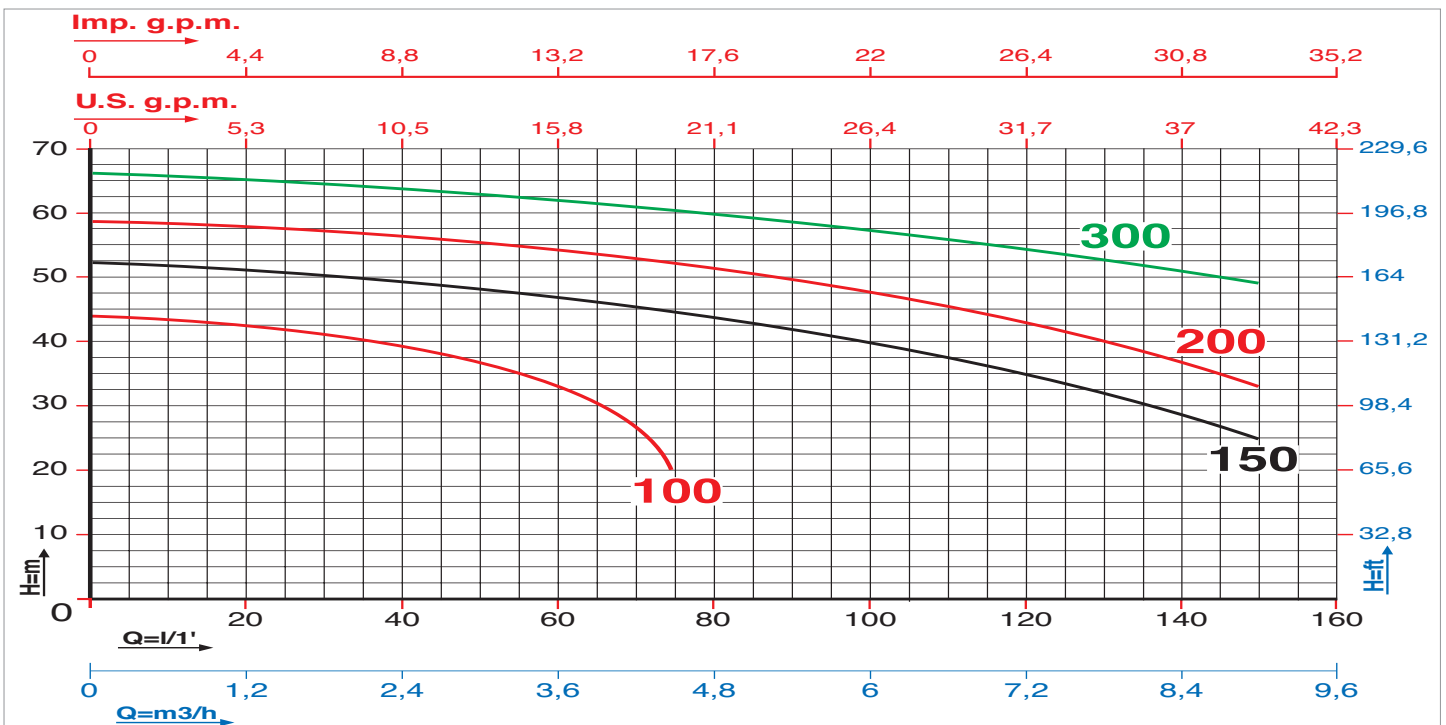

Caratteristiche di funzionamento a 2800 rpm 50Hz e 3450 rpm 60Hz - Performances at 2800 rpm 50 Hz and 3450 rpm 60 Hz  
 Le prestazioni valgono per liquidi con densità  $\rho = 1,0 \text{ kg/dm}^3$  ed una viscosità  $\nu = 1 \text{ mm}^2/\text{s}$  / The performance data holds true for liquids with a  $\rho = 1,0 \text{ kg/dm}^3$  density and a  $\nu = 1 \text{ mm}^2/\text{s}$  viscosity.

MODELLO MODEL	VOLTAGGIO VOLTAGE 50 Hz	DATI ELETTRICI / ELECTRICAL DATA						DATI IDRAULICI / HYDRAULIC DATA								PRESSIONE TOTALE IN METRI COLONNA ACQUA TOTAL PUMP HEAD AND WATER COLUMN HEIGHT IN m.	
		P1max kW	P2 nom.		I max Ampere	Condensatore Capacitor		H (m)									
			kW	HP		µF	VC	0	1,5	3	6	9	12	15	18		
RB 100 M	1 x 220-230V	1,25	0,75	1,0	5,5	20,0	450	44,0	41,0	37,0	---	---	---	---	---	---	---
RB 150 M	1 x 220-230V	2,2	1,1	1,5	10,0	35,0	450	52,0	50,5	48,5	40,0	25,0	---	---	---	---	---
RB 150 T	3 x 380-440V	2,2	1,1	1,5	4,3	---	---	52,0	50,5	48,5	40,0	25,0	---	---	---	---	---
RB 200 M	1 x 220-230V	2,6	1,5	2,0	12,0	35,0	450	58,0	57,5	55,5	47,5	33,0	---	---	---	---	---
RB 200 T	3 x 380-440V	2,6	1,5	2,0	5,0	---	---	58,0	57,5	55,5	47,5	33,0	---	---	---	---	---
RB 300 T	3 x 380-440V	3,6	2,2	3,0	7,0	---	---	66,0	64,5	63,0	57,0	49,0	---	---	---	---	---
RB 400 T	3 x 380-440V	4,5	3,0	4,0	7,5	---	---	73,5	72,0	69,5	63,0	55,0	43,0	---	---	---	---
RB 550 T	3 x 380-440V	6,0	4,0	5,5	9,3	---	---	88,0	86,0	84,0	77,0	68,0	56,0	---	---	---	---
RB 750 T	3 x 380-440V	8,0	5,5	7,5	13,0	---	---	90,0	89,5	89,0	87,0	82,5	76,0	64,0	49,0	---	---

**DIMENSIONI e PESI / SIZE AND WEIGHT DATA:**

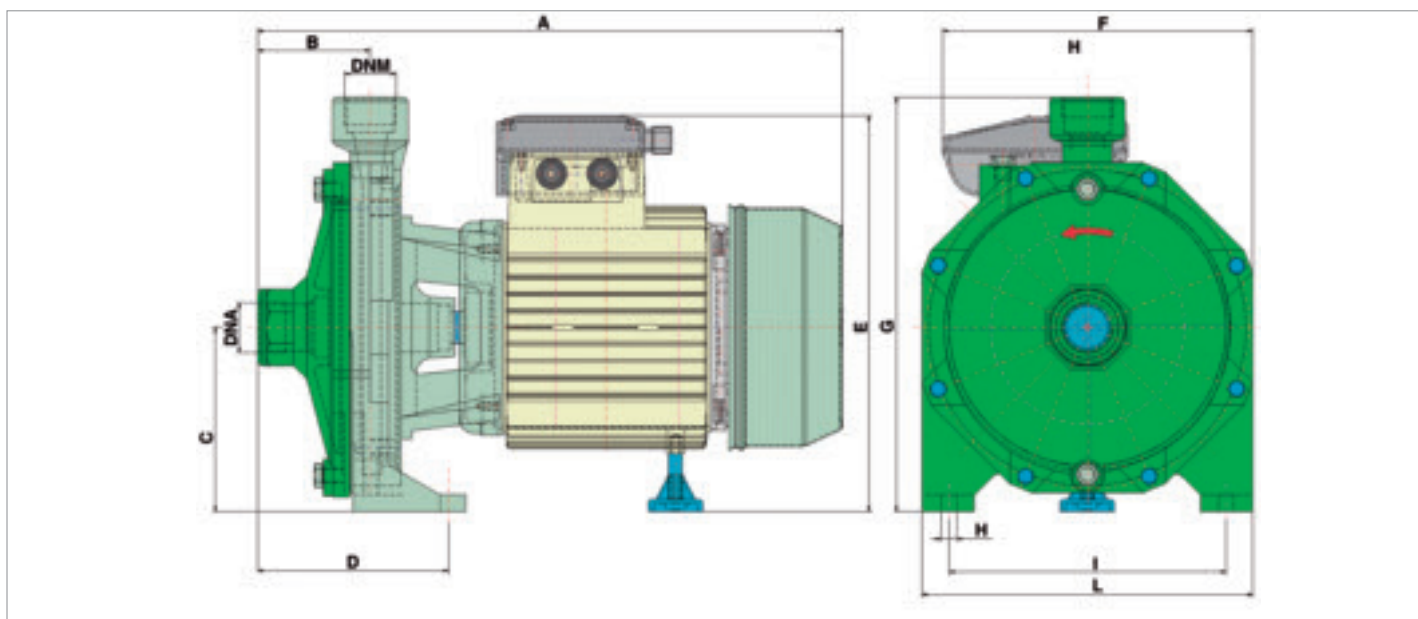
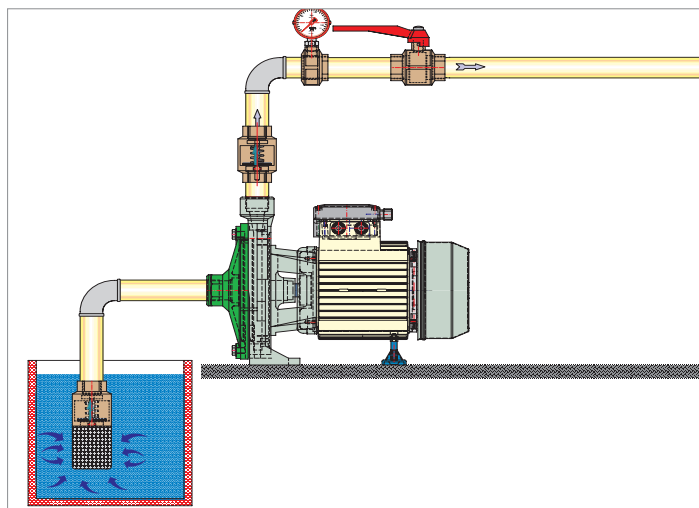
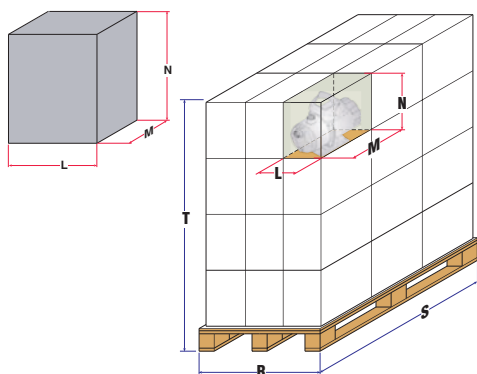

MODELLO / MODEL	DIMENSIONI POMPA in mm. / PUMP DIMENSIONS in mm.											
	DNA	DNM	A	B	C	D	E	F	G	H	I	L
RB 100	1"	1"	340	75	100	80	210	185	220	10	140	170
RB 150	1" 1/4	1"	400	85	120	95	255	222	265	10	168	208
RB 200	1" 1/4	1"	432	85	120	95	255	222	265	10	168	208
RB 300	1" 1/4	1"	440	92,5	132	108,5	280	246	290	12	190	230
RB 400	1" 1/2	1" 1/4	485	94	160	120	330	272	340	15	200	250
RB 550	1" 1/2	1" 1/4	495	94	160	120	330	272	340	15	200	250
RB 750	2"	1" 1/4	575	107	160	121	365	300	375	15	225	280

MODELLO MODEL	DIMENSIONI SCATOLA / PACKING DIMENSIONS			
	L mm	M mm	N mm	Peso / Weight Kg
RB 100	357	197	270	16,0
RB 150	412	230	310	23,5
RB 200	412	230	310	26,0
RB 300	530	300	460	27,0
RB 400	530	300	460	46,0
RB 550	530	300	460	53,0
RB 750	610	330	480	71,0

# RPG



## **ELETTROPOMPE CENTRIFUGHE MULTICELLULARI IN GHISA CENTRIFUGAL MULTISTAGE ELECTRIC CAST IRON PUMPS**

**PREVALENZA** ..... : 44 mt. ÷ 90 mt.  
**PORTATA** ..... : 3 m<sup>3</sup>/h ÷ 16,5 m<sup>3</sup>/h  
**POTENZA NOMINALE** : 0,55 kW (0,75HP) ÷ 0,75 kW (1,0HP)

**PUMP HEAD** ..... : 44,0 mt ÷ 90,0 mt  
**DELIVERY** ..... : 3,0m<sup>3</sup>/h ÷ 16,5 m<sup>3</sup>/h  
**RATED HORSEPOWER** : 0,55 kW (0,75HP) ÷ 0,75 kW (1,0HP)

### **APPLICAZIONI**

- PRESSURIZZAZIONE DI IMPIANTI DOMESTICI E PICCOLA IRRIGAZIONE.
- MOVIMENTAZIONE DI LIQUIDI NON AGGRESSIVI PER USI CIVILI ED INDUSTRIALI.
- IMPIANTI DI LAVAGGIO, INSERIMENTO SU MACCHINARI PIU' COMPLESSI PER USI INDUSTRIALI.

### **APPLICATIONS**

- FOR DOMESTIC SYSTEMS AND SMALL IRRIGATION SYSTEM PRESSURISATION.
- HANDLING OF NON AGGRESSIVE CIVIL AND INDUSTRIAL LIQUIDS.
- FOR WASHING SYSTEMS AND FOR INSERTION INTO COMPLEX INDUSTRIAL MACHINERY AND LINES.

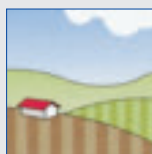
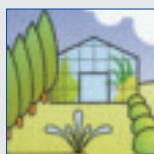

**AV ARVEN**

**CARATTERISTICHE DI COSTRUZIONE**

- MOTORE CHIUSO CON VENTILAZIONE ESTERNA E CASSA ALETTATA IN LEGA DI ALLUMINIO.
- GRADO DI PROTEZIONE IP 44.
- CLASSE DI ISOLAMENTO: F.
- TEMPERATURA MAX.LIQUIDO POMPATO: 35°C.
- VERSIONI: Monofase: 220 - 230V/50Hz o 220 - 230V/60Hz con protettore termico incorporato e condensatore permanentemente inserito.  
Trifase: 220 - 230V/50Hz e 380 - 400V/50Hz o 220 - 230V/60Hz e 380 - 400V/60Hz con protezione da sovraccarico a cura dell'utente.
- POTENZA MOTORE: 1 Hp solo VERSIONE MONOFASE.  
DA 1,5 Hp a 2 Hp VERSIONE MONOFASE E TRIFASE  
DA 3 Hp a 7,5 SOLO VERSIONE TRIFASE.

SPECIALI VOLTAGGI E FREQUENZE A RICHIESTA.

**DESIGN ENGINEERING**

- SEALED MOTOR WITH EXTERNAL VENTILATION AND FINNED ALUMINIUM ALLOY CASING.
  - IP 44 PROTECTION CLASS.
  - CLASS "F" INSULATION.
  - MAX. PUMPED LIQUID TEMPERATURE: 35°C.
  - VERSIONS: Single Phase: 220 - 230 V/50 Hz with built in thermal protection and permanent capacitor.  
Three Phase: 220 - 230V/50Hz or 380 - 400V/50Hz and 220 - 230V/60Hz or 380 - 400V/60Hz with overload protection care of the User.
  - MOTOR POWER: 1 Hp only single phase versions.  
From 1.5 Hp to 2 Hp single phase and three phases versions  
From 3 Hp to 7,5 only Three Phases versions.
- CUSTOMISED VOLTAGE AND FREQUENCY RATING AVAILABLE ON DEMAND.

**TABELLA MATERIALI / MATERIALS TABLE:**

Pos.	Componente / Component	Materiale / Materials
A	Corpo pompa / Pump body	GHISA / CAST IRON
B	Girante / Impeller	NORYL
C	Tenuta meccanica / Mechanical Seal	CERAMICA-GRAFITE / CERAMIC-GRAPHITE
D	Flangia / Flange	GHISA / CAST IRON
E	Albero (lato pompa) / Shaft (pump face)	ACCIAIO INOX / STAINLESS STEEL

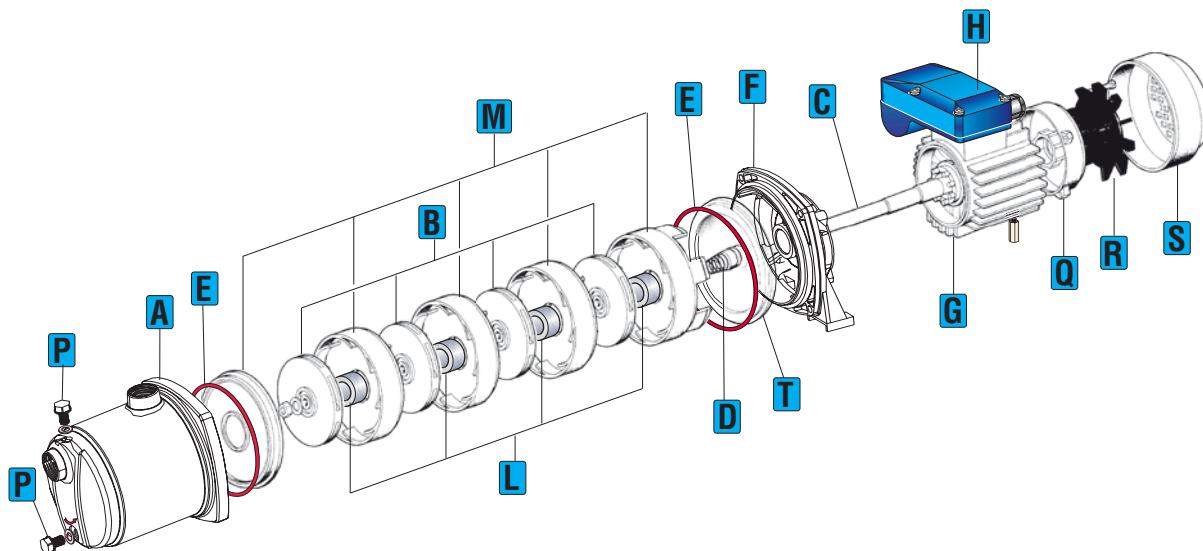



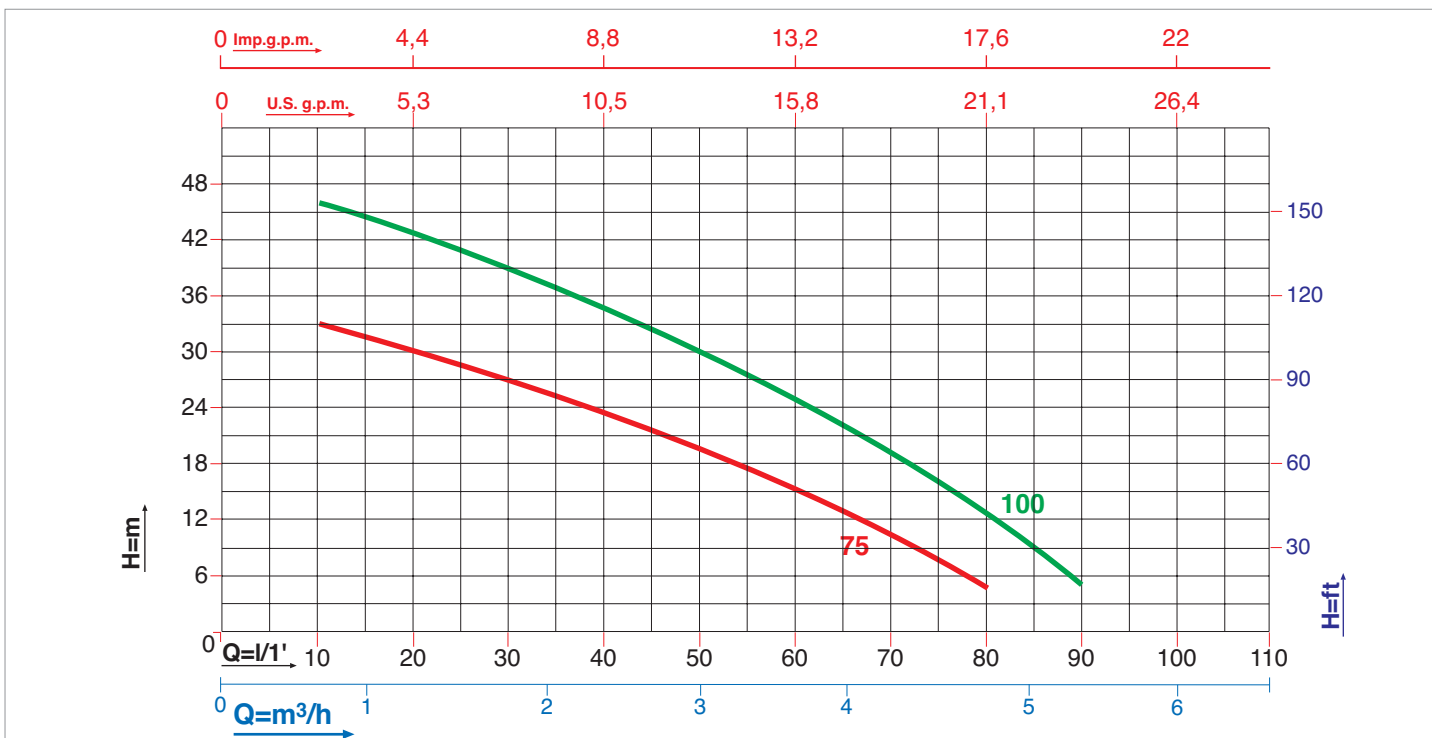

Caratteristiche di funzionamento a 2800 rpm 50Hz e 3450 rpm 60Hz - Performances at 2800 rpm 50 Hz and 3450 rpm 60 Hz  
 Le prestazioni valgono per liquidi con densità  $\rho = 1,0 \text{ kg/dm}^3$  ed una viscosità  $\nu = 1 \text{ mm}^2/\text{s}$  / The performance data holds true for liquids with a  $\rho = 1,0 \text{ kg/dm}^3$  density and a  $\nu = 1 \text{ mm}^2/\text{s}$  viscosity.

MODELLO MODEL	VOLTAGGIO VOLTAGE 50 Hz	DATI ELETTRICI / ELECTRICAL DATA						DATI IDRAULICI / HYDRAULIC DATA										
		P1 max		P2 nom.		I max	Condensatore Capacitor		m³/h	0,6	1,2	1,8	2,4	3	3,6	4,2	4,8	5,4
		kW	kW	HP	Ampere	µF	VC	l/min.	10	20	30	40	50	60	70	80	90	
RPG 75 M	1 x 220-230V	0,75	0,55	0,75	3,3	16	450	H (m)	33,0	30,0	26,0	23,5	18,5	14,0	10,0	5,0	---	
RPG 100 M	1 x 220-230V	1,0	0,75	1,0	4,3	20	450	H (m)	46,0	43,0	39,0	35,0	30,0	24,0	16,5	10,0	5,0	

PREVALENZA TOTALE IN METRI COLONNA ACQUA  
 TOTAL PUMP HEAD AND WATER COLUMN HEIGHT IN m.

**DIMENSIONI e PESI / SIZE AND WEIGHT DATA:**

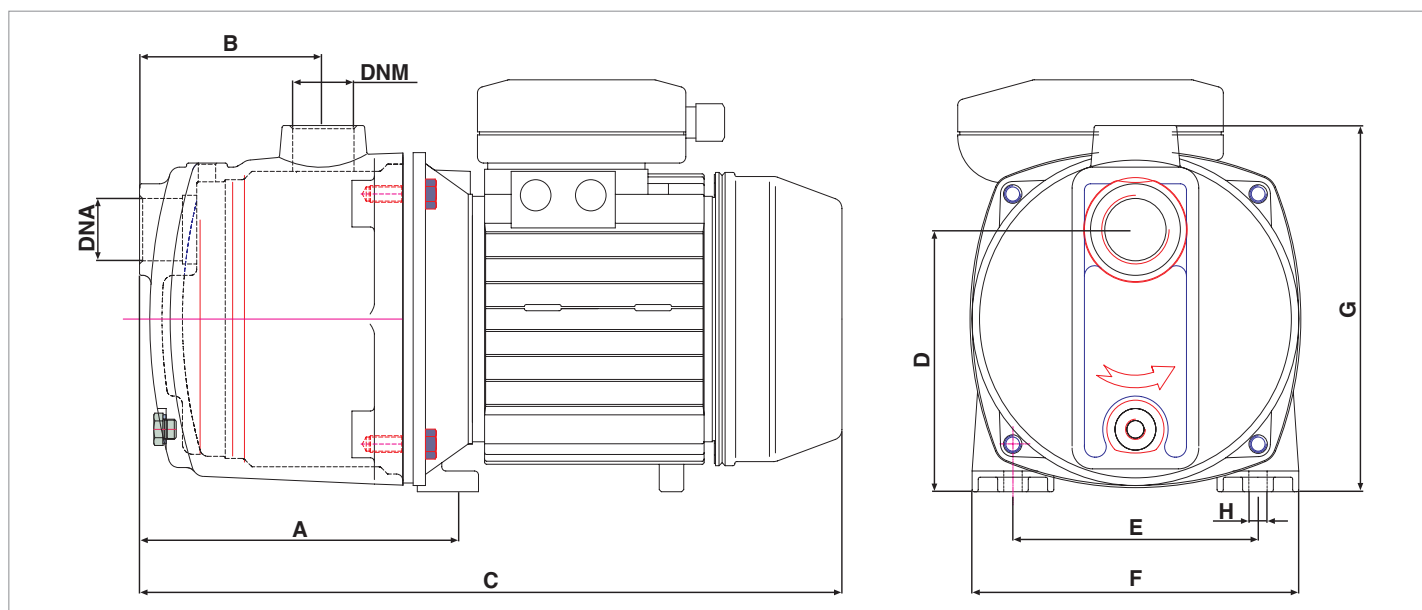
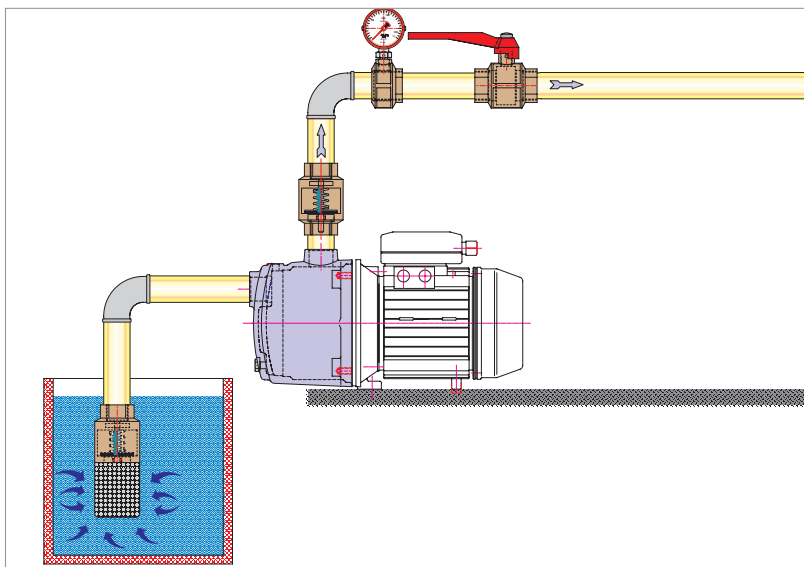
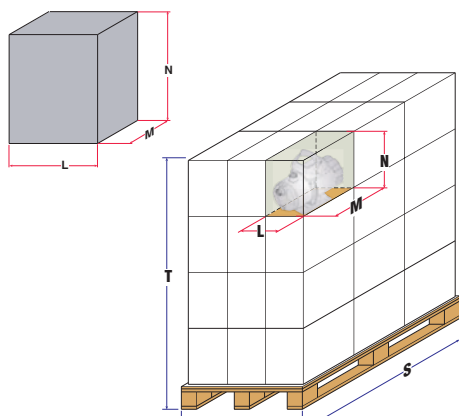

MODELLO / MODEL	DIMENSIONI POMPA in mm. / PUMP DIMENSIONS in mm.									
	DNA	DNM	A	B	C	D	E	F	G	H
RPG 75 M	1"	1"	96	103	325	135	120	154	178	9
RPG 100 M	1"	1"	119	128	376	135	120	154	193	9

MODELLO MODEL	DIMENSIONI SCATOLA / PACKING DIMENSIONS			
	L mm	M mm	N mm	Peso / Weight Kg
RPG 75 M	345	175	220	10,5
RPG 100 M	400	175	240	13,5

# RPX



## **ELETTROPOMPE CENTRIFUGHE MULTICELLULARI IN ACCIAIO INOX CENTRIFUGAL MULTISTAGE ELECTRIC STAINLESS STEEL PUMPS**

**PREVALENZA** ..... : 34 mt. ÷ 58 mt.  
**PORTATA** ..... : 4,8 m<sup>3</sup>/h ÷ 5,4 m<sup>3</sup>/h  
**POTENZA NOMINALE** : 0,7 kW (0,9HP) ÷ 1,0 kW (1,3HP)

**PUMP HEAD** ..... : 34,0 mt ÷ 58,0 mt  
**DELIVERY** ..... : 4,2 m<sup>3</sup>/h ÷ 5,4 m<sup>3</sup>/h  
**RATED HORSEPOWER** : 0,7 kW (0,9HP) ÷ 1,0 kW (1,3HP)

### **APPLICAZIONI**

- PRESSURIZZAZIONE DI IMPIANTI DOMESTICI E PICCOLA IRRIGAZIONE.
- MOVIMENTAZIONE DI LIQUIDI NON AGGRESSIVI PER USI CIVILI ED INDUSTRIALI.
- IMPIANTI DI LAVAGGIO, INSERIMENTO SU MACCHINARI PIU' COMPLESSI PER USI INDUSTRIALI.

### **APPLICATIONS**

- FOR DOMESTIC SYSTEMS AND SMALL IRRIGATION SYSTEM PRESSURISATION.
- HANDLING OF NON AGGRESSIVE CIVIL AND INDUSTRIAL LIQUIDS.
- FOR WASHING SYSTEMS AND FOR INSERTION INTO COMPLEX INDUSTRIAL MACHINERY AND LINES.

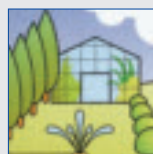

**AV ARVEN**

**CARATTERISTICHE DI COSTRUZIONE**

- MOTORE CHIUSO CON VENTILAZIONE ESTERNA E CASSA ALETTATA IN LEGA DI ALLUMINIO.
- GRADO DI PROTEZIONE IP 44.
- CLASSE DI ISOLAMENTO: F.
- TEMPERATURA MAX.LIQUIDO POMPATO: 35°C.
- VERSIONI: Monofase: 220 - 230V/50Hz o 220 - 230V/60Hz con protettore termico incorporato e condensatore permanentemente inserito.
- POTENZA MOTORE: DA 0,9 Hp ÷ 1,3 Hp solo VERSIONE MONOFASE.

SPECIALI VOLTAGGI E FREQUENZE A RICHIESTA.

**DESIGN ENGINEERING**

- SEALED MOTOR WITH EXTERNAL VENTILATION AND FINNED ALUMINIUM ALLOY CASING.
- IP 44 PROTECTION CLASS.
- CLASS "F" INSULATION.
- MAX. PUMPED LIQUID TEMPERATURE: 35°C.
- VERSIONS: Single Phase: 220 - 230 V/50 ou 220 - 230V/60Hz Hz with built in thermal protection and permanent capacitor.
- MOTOR POWER: From 0.9 Hp to 1.3 Hp only single phase versions.

CUSTOMISED VOLTAGE AND FREQUENCY RATING AVAILABLE ON DEMAND.

**TABELLA MATERIALI / MATERIALS TABLE:**

Pos.	Componente / Component	Materiale / Materials
A	Corpo pompa / Pump body	ACCIAIO INOX / STAINLESS STEEL
B	Diffusore / Diffuser	NORYL
C	Girante / Impeller	NORYL
D	Tenuta meccanica / Mechanical Seal	CERAMICA-GRAFITE / CERAMIC-GRAPHITE
E	Flangia / Flange	GHISA / CAST IRON
F	Albero (lato pompa) / Shaft (pump face)	ACCIAIO INOX / STAINLESS STEEL

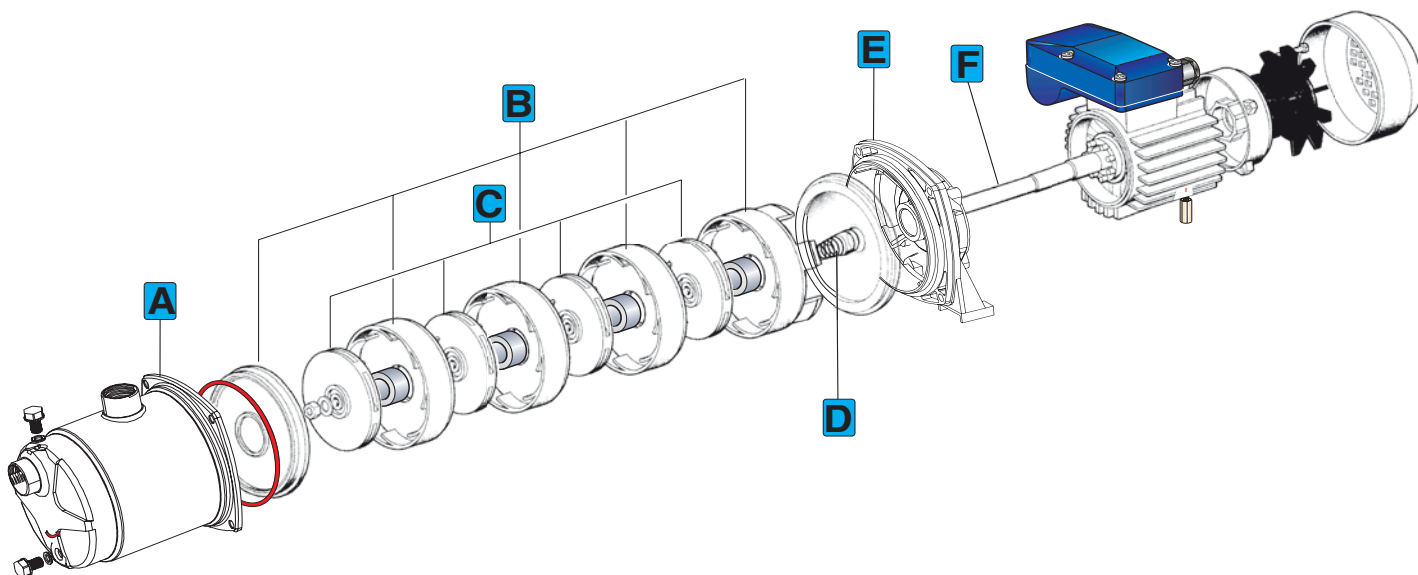

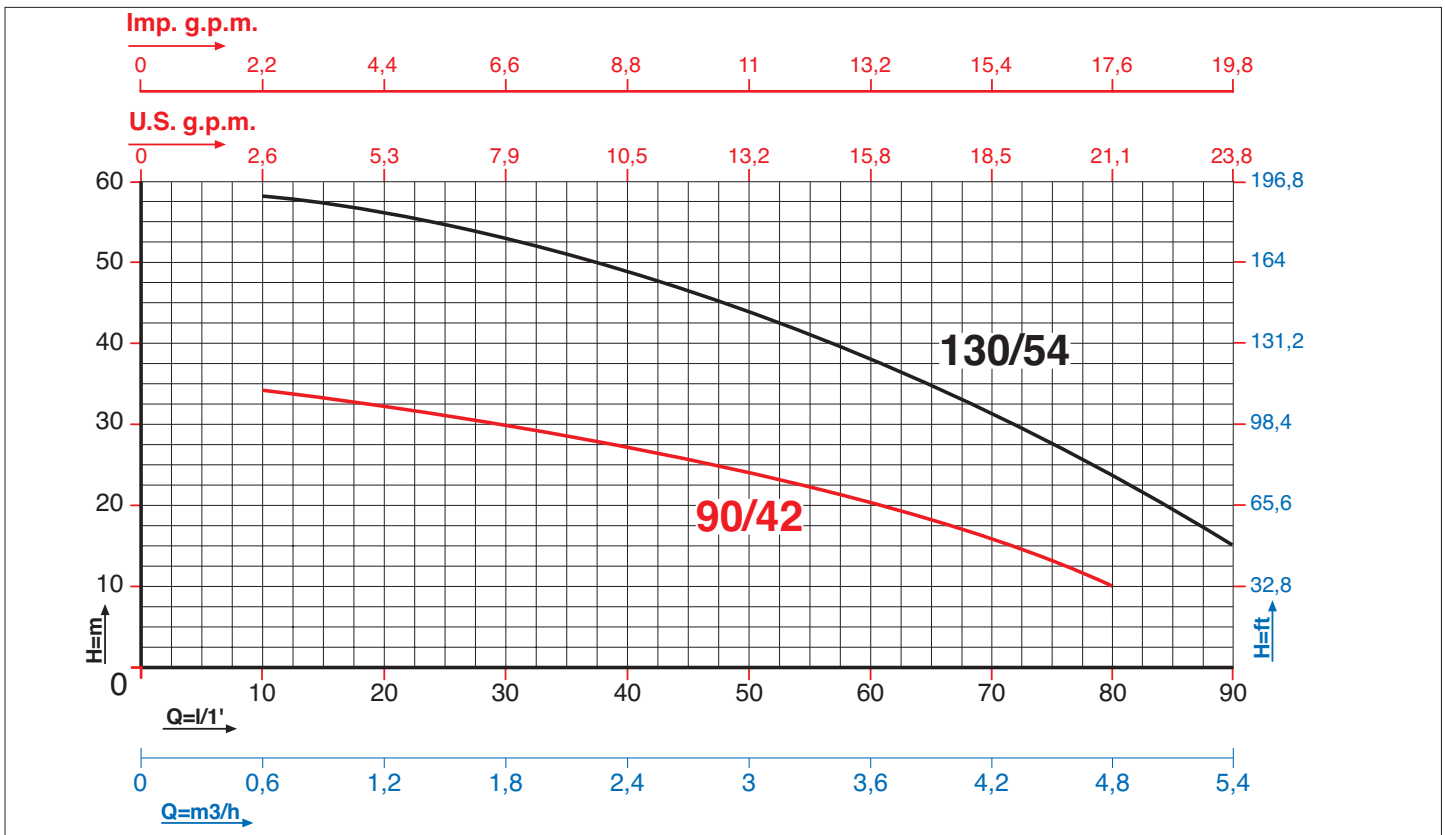

Caratteristiche di funzionamento a 2800 rpm 50Hz e 3450 rpm 60Hz - Performances at 2800 rpm 50 Hz and 3450 rpm 60 Hz  
 Le prestazioni valgono per liquidi con densità  $\rho = 1,0 \text{ kg/dm}^3$  ed una viscosità  $\nu = 1 \text{ mm}^2/\text{s}$  / The performance data holds true for liquids with a  $\rho = 1,0 \text{ kg/dm}^3$  density and a  $\nu = 1 \text{ mm}^2/\text{s}$  viscosity.

MODELLO MODEL	VOLTAGGIO VOLTAGE 50 Hz	DATI ELETTRICI / ELECTRICAL DATA						DATI IDRAULICI / HYDRAULIC DATA										
		P1 max		P2 nom.		I max	Condensatore Capacitor		m³/h	0,6	1,2	1,8	2,4	3	3,6	4,2	4,8	5,4
		kW	kW	HP	Ampere	µF	VC	l/min.	10	20	30	40	50	60	70	80	90	
RPX 90/42 M	1 x 220-230V	0,9	0,7	0,9	4,0	12,5	450	H (m)	34,0	32,0	30,0	28,0	24,0	20,0	15,0	10,0	---	
RPX 130/54 M	1 x 220-230V	1,3	1,0	1,3	5,8	20,0	450		58,0	56,0	52,0	48,0	44,0	39,0	31,0	23,0	15,0	

PREVALENZA TOTALE in METRI COLONNA ACQUA / TOTAL PUMP HEAD AND WATER COLUMN HEIGHT IN m.

**DIMENSIONI e PESI / SIZE AND WEIGHT DATA:**

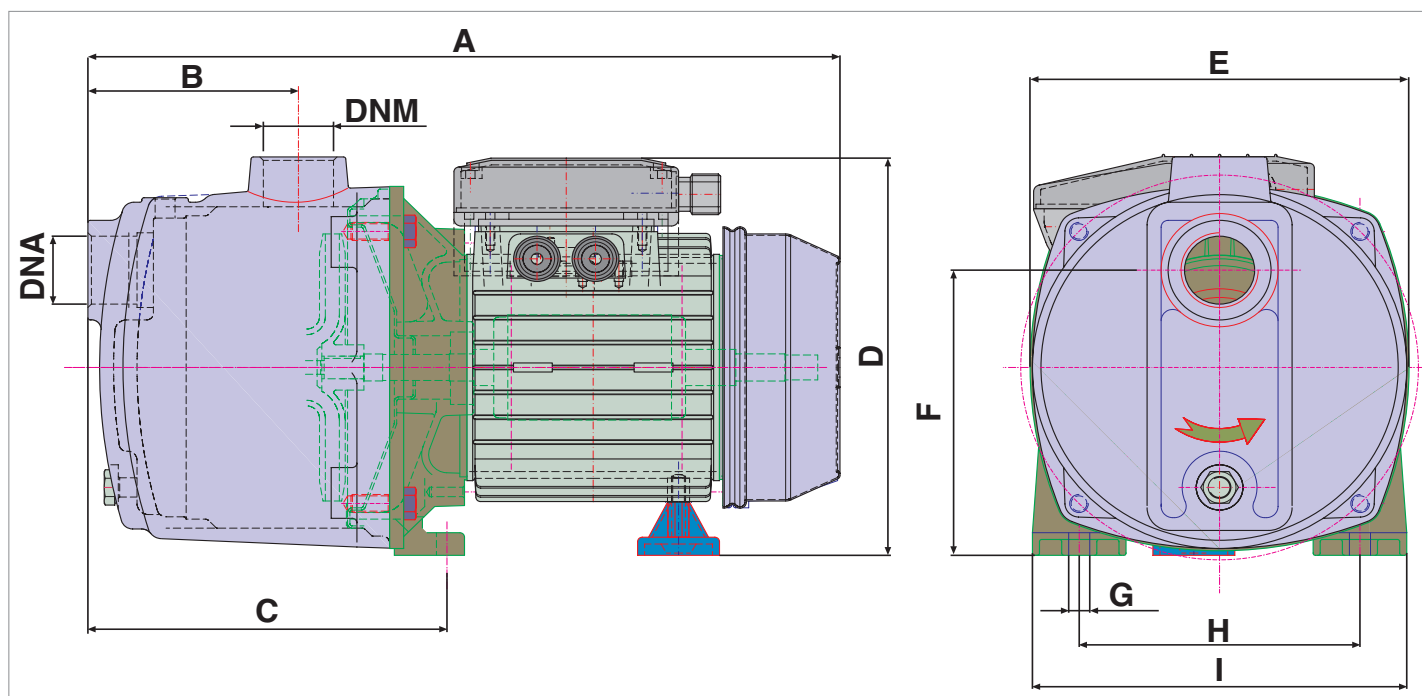
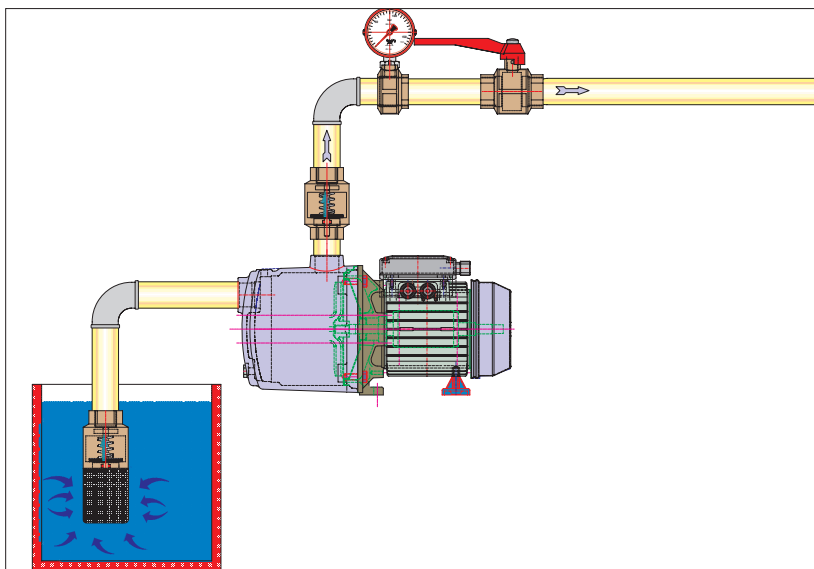
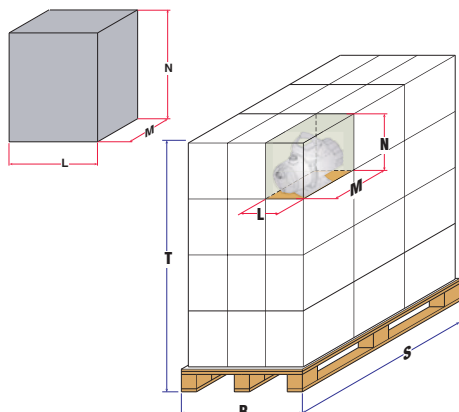

MODELLO / MODEL	DIMENSIONI POMPA in mm. / PUMP DIMENSIONS in mm.										
	DNA	DNM	A	B	C	D	E	F	G	H	I
RPX 90/42	1"	1"	343	81	163	200	184	149	9	140	176
RPX 130/54	1"	1"	415	113	210	212	206	154	9	140	176

MODELLO MODEL	DIMENSIONI SCATOLA / PACKING DIMENSIONS			
	L mm	M mm	N mm	Peso / Weight Kg
RPX 90/42	420	190	230	8,5
RPX 130/54	450	210	240	13,0



# RM



## **ELETTROPOMPE CENTRIFUGHE MULTICELLULARI IN ACCIAIO INOX** ***CENTRIFUGAL MULTISTAGE ELECTRIC STAINLESS STEEL PUMPS***

**PREVALENZA** ..... : 34 mt. ÷ 60 mt.  
**PORTATA** ..... : 5,4 m<sup>3</sup>/h  
**POTENZA NOMINALE** : 0,6 kW (0,8HP) ÷ 1,1 kW (1,5HP)

**PUMP HEAD** ..... : 34,0 mt ÷ 60,0 mt  
**DELIVERY** ..... : 5,4 m<sup>3</sup>/h  
**RATED HORSEPOWER** : 0,6 kW (0,8HP) ÷ 1,1 kW (1,5HP)

### **APPLICAZIONI**

- PRESSURIZZAZIONE DI IMPIANTI DOMESTICI E PICCOLA IRRIGAZIONE.
- MOVIMENTAZIONE DI LIQUIDI NON AGGRESSIVI PER USI CIVILI ED INDUSTRIALI.
- IMPIANTI DI LAVAGGIO, INSERIMENTO SU MACCHINARI PIU' COMPLESSI PER USI INDUSTRIALI.

### **APPLICATIONS**

- FOR DOMESTIC SYSTEMS AND SMALL IRRIGATION SYSTEM PRESSURISATION.
- HANDLING OF NON AGGRESSIVE CIVIL AND INDUSTRIAL LIQUIDS.
- FOR WASHING SYSTEMS AND FOR INSERTION INTO COMPLEX INDUSTRIAL MACHINERY AND LINES.

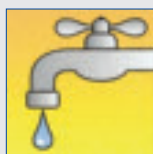

**AV ARVEN**

**CARATTERISTICHE DI COSTRUZIONE**

- MOTORE CHIUSO CON VENTILAZIONE ESTERNA E CASSA ALETTATA IN LEGA DI ALLUMINIO.
- GRADO DI PROTEZIONE IP 44.
- CLASSE DI ISOLAMENTO: F.
- TEMPERATURA MAX.LIQUIDO POMPATO: 35°C.
- VERSIONI: Monofase: 220 - 230V/50Hz o 220 - 230V/60Hz con protettore termico incorporato e condensatore permanentemente inserito.  
Trifase: 220 - 230V/50Hz e 380 - 400V/50Hz o 220 - 230V/60Hz e 380 - 400V/60Hz con protezione da sovraccarico a cura dell'utente.
- POTENZA MOTORE: 0,8 Hp solo VERSIONE MONOFASE.  
DA 1,0 Hp a 1,5 Hp VERSIONE MONOFASE E TRIFASE

SPECIALI VOLTAGGI E FREQUENZE A RICHIESTA.

**DESIGN ENGINEERING**

- SEALED MOTOR WITH EXTERNAL VENTILATION AND FINNED ALUMINIUM ALLOY CASING.
- IP 44 PROTECTION CLASS.
- CLASS "F" INSULATION.
- MAX. PUMPED LIQUID TEMPERATURE: 35°C.
- VERSIONS: Single Phase: 220 - 230 V/50 Hz with built in thermal protection and permanent capacitor.  
Three Phase: 220 - 230V/50Hz or 380- 400V/50Hz and 220 - 230V/60Hz or 380 - 400V/60Hz with overload protection care of the User.
- MOTOR POWER: 0.8 Hp only single phase versions.  
From 1.0 Hp to 1.5 Hp single phase and three phases versions

CUSTOMISED VOLTAGE AND FREQUENCY RATING AVAILABLE ON DEMAND.

**TABELLA MATERIALI / MATERIALS TABLE:**

Pos.	Componente / Component	Materiale / Materials
A	Corpo pompa / Pump body	GHISA / CAST IRON
B	Diffusore / Diffuser	NORYL
C	Girante / Impeller	NORYL
D	Tenuta meccanica / Mechanical Seal	CERAMICA-GRAFITE / CERAMIC-GRAPHITE
E	Flangia / Flange	GHISA / CAST IRON
F	Albero (lato pompa) / Shaft (pump face)	ACCIAIO INOX / STAINLESS STEEL
G	Porta diffusori / Diffuser Body	ACCIAIO INOX / STAINLESS STEEL

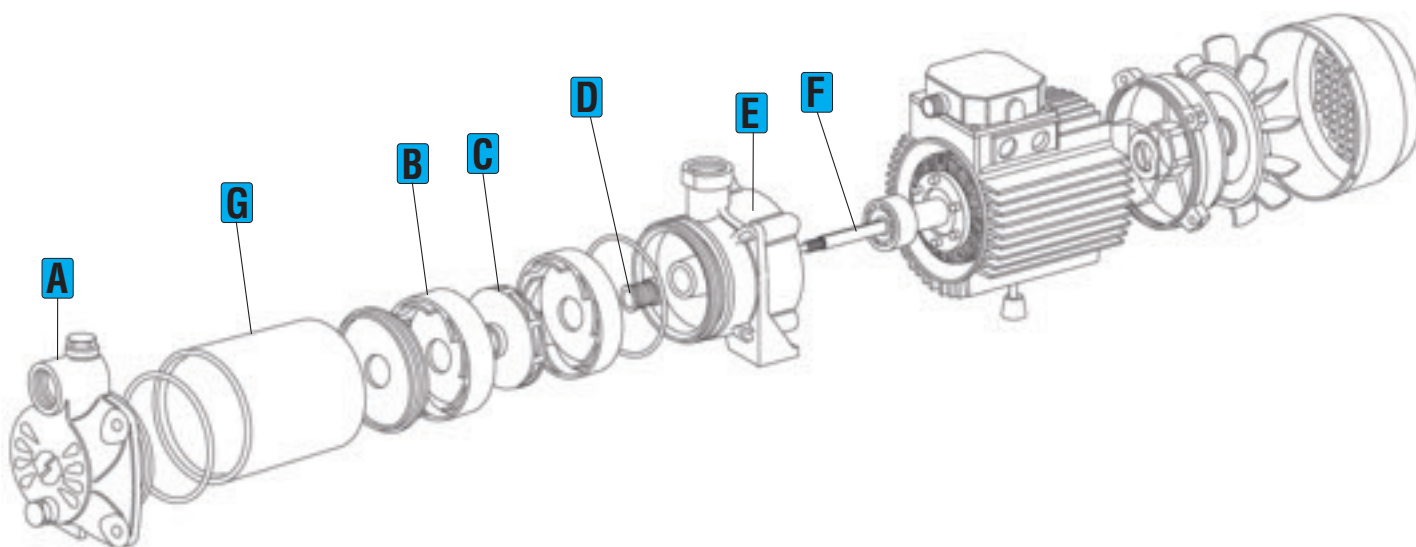

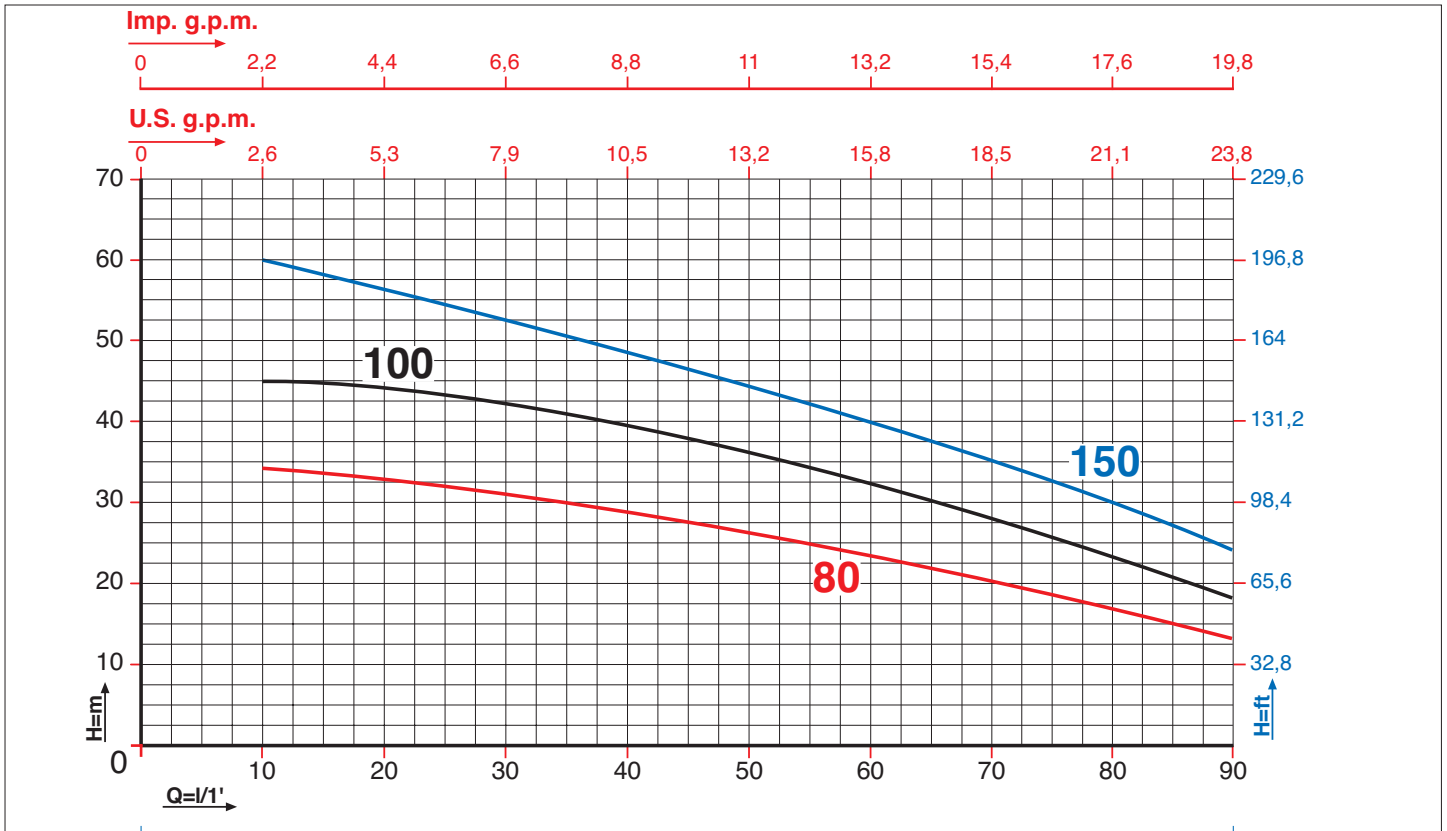

Caratteristiche di funzionamento a 2800 rpm 50Hz e 3450 rpm 60Hz - Performances at 2800 rpm 50 Hz and 3450 rpm 60 Hz  
 Le prestazioni valgono per liquidi con densità  $\rho = 1,0 \text{ kg/dm}^3$  ed una viscosità  $\nu = 1 \text{ mm}^2/\text{s}$  / The performance data holds true for liquids with a  $\rho = 1,0 \text{ kg/dm}^3$  density and a  $\nu = 1 \text{ mm}^2/\text{s}$  viscosity.

MODELLO MODEL	VOLTAGGIO VOLTAGE 50 Hz	DATI ELETTRICI / ELECTRICAL DATA						DATI IDRAULICI / HYDRAULIC DATA										
		P1 max		P2 nom.		I max	Condensatore Capacitor		m <sup>3</sup> /h	0,6	1,2	1,8	2,4	3	3,6	4,2	4,8	5,4
		kW	kW	HP	Ampere	$\mu\text{F}$	VC	l/min.	10	20	30	40	50	60	70	80	90	
RM 80 M	1 x 220-230V	0,8	0,6	0,8	3,5	16,0	450	H (m)	34,0	33,0	31,0	38,5	26,5	23,0	20,0	17,0	13,0	
RM 100 M	1 x 220-230V	1,0	0,7	1,0	4,8	20,0	450		45,0	44,0	43,0	39,0	36,0	33,0	29,5	23,5	18,0	
RM 100 T	3 x 380-400V	1,0	0,7	1,0	2,2	---	---		45,0	44,0	43,0	39,0	36,0	33,0	29,5	23,5	18,0	
RM 150 M	1 x 220-230V	1,4	1,1	1,5	6,2	20,0	450		60,0	56,0	53,0	48,5	44,0	40,0	35,0	30,0	24,0	
RM 150 T	3 x 380-400V	1,4	1,1	1,5	3,0	---	---		60,0	56,0	53,0	48,5	44,0	40,0	35,0	30,0	24,0	

PREVALENZA TOTALE in METRI COLONNA ACQUA / TOTAL PUMP HEAD AND WATER COLUMN HEIGHT IN m.

**DIMENSIONI e PESI / SIZE AND WEIGHT DATA:**

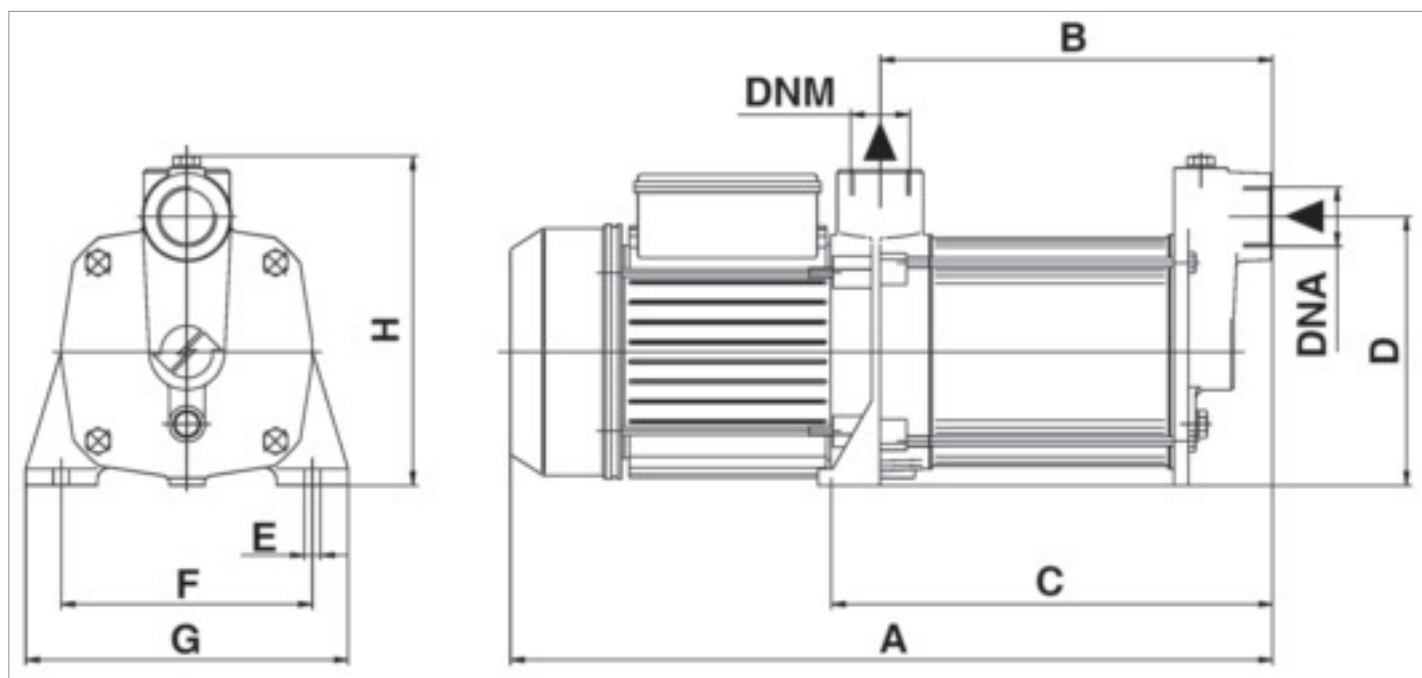
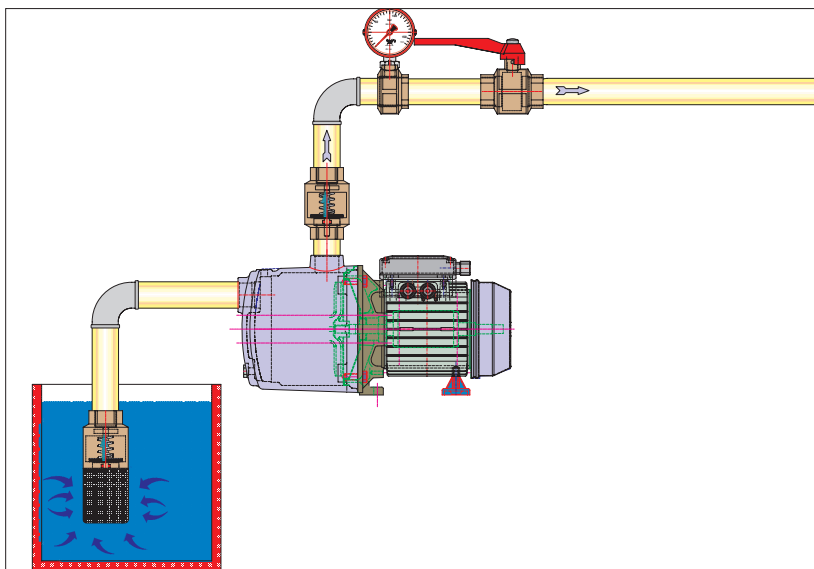
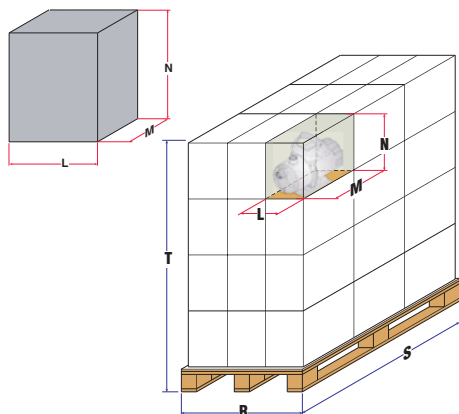

MODELLO / MODEL	DIMENSIONI POMPA in mm. / PUMP DIMENSIONS in mm.									
	DNA	DNM	A	B	C	D	E	F	G	H
RM 80	1"	1"	375	170	195	150	9,5	140	180	185
RM 100	1"	1"	400	194	220	150	9,5	140	180	185
RM 150	1"	1"	420	218	245	150	9,5	140	180	185

MODELLO MODEL	DIMENSIONI SCATOLA / PACKING DIMENSIONS			
	L mm	M mm	N mm	Peso / Weight Kg
RM 80	445	200	210	13,2
RM 100	445	200	210	14,5
RM 150	445	200	210	14,8

# CR



## **ELETTROPOMPE CENTRIFUGHE MONOBLOCCO MONOBLOCK CENTRIFUGAL PUMPS**

**PREVALENZA** ..... : 24,0 mt. ÷ 91,5 mt.  
**PORTATA** ..... : 27,0 m<sup>3</sup>/h ÷ 240 m<sup>3</sup>/h  
**POTENZA NOMINALE** : 1,5 kW (2,0HP) ÷ 37,0 kW (50HP)

**PUMP HEAD** ..... : 24,0 mt ÷ 91,5 mt  
**DELIVERY** ..... : 27,0 m<sup>3</sup>/h ÷ 240 m<sup>3</sup>/h  
**RATED HORSEPOWER** : 1,5 kW (2,0HP) ÷ 37,0 kW (50,0HP)

### **APPLICAZIONI**

- APPROVVIGIONAMENTI D'ACQUA, IRRIGAZIONI A PIOGGIA O A SCORRIMENTO.
- MOVIMENTAZIONE DI LIQUIDI NON AGGRESSIVI PER USI CIVILI ED INDUSTRIALI.
- ALIMENTAZIONI AUTOCLAVI E SOPRAELEVAZIONI DI PRESSIONE RISCALDAMENTO E CONDIZIONAMENTO.

### **APPLICATIONS**

- WATER SUPPLY, SPRAY OR FLOWING IRRIGATION.
- HANDLING OF NON AGGRESSIVE CIVIL AND INDUSTRIAL LIQUIDS.
- AUTOCLAVE FEE, HIGH PRESSURE SYSTEM, HEATING, CONDITIONING

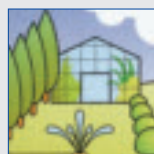

**AV ARVEN**

**CARATTERISTICHE DI COSTRUZIONE**

- MOTORE CHIUSO CON VENTILAZIONE ESTERNA E CASSA ALETTATA IN LEGA DI ALLUMINIO.
- GRADO DI PROTEZIONE IP 55.
- CLASSE DI ISOLAMENTO: F.
- TEMPERATURA MAX. LIQUIDO POMPATO: 35°C.
- VERSIONI: Monofase: 220 - 230V/50Hz o 220 - 230V/60Hz con protettore termico incorporato e condensatore permanentemente inserito.  
Trifase: 220 - 230V/50Hz e 380 - 400V/50Hz o 220 - 230V/60Hz e 380 - 400V/60Hz con protezione da sovraccarico a cura dell'utente.
- POTENZA MOTORE: DA 2Hp a 5,5 Hp VERSIONE MONOFASE E TRIFASE. DA 7,5 Hp a 50 Hp SOLO VERSIONE TRIFASE

SPECIALI VOLTAGGI E FREQUENZE A RICHIESTA.

**DESIGN ENGINEERING**

- SEALED MOTOR WITH EXTERNAL VENTILATION AND FINNED ALUMINIUM ALLOY CASING.
- IP 55 PROTECTION CLASS.
- CLASS "F" INSULATION.
- MAX. PUMPED LIQUID TEMPERATURE: 35°C.
- VERSIONS: Single Phase: 220 - 230 V/50 Hz with built in thermal protection and permanent capacitor.  
Three Phase: 220 - 230V/50Hz or 380- 400V/50Hz and 220 - 230V/60Hz or 380 - 400V/60Hz with overload protection care of the User.
- MOTOR POWER: From 2Hp to 5,5Hp single phase versions and three versions From 7,5 Hp to 50 Hp only three phases versions

CUSTOMISED VOLTAGE AND FREQUENCY RATING AVAILABLE ON DEMAND.

**TABELLA MATERIALI / MATERIALS TABLE:**

Pos.	Componente / Component	Materiale / Materials
A	Corpo pompa / Pump body	GHISA / CAST IRON
B	Diffusore / Diffuser	GHISA / CAST IRON
C	Girante / Impeller	GHISA / CAST IRON
D	Tenuta meccanica / Mechanical Seal	CERAMICA-GRAFITE / CERAMIC-GRAPHITE
E	Flangia / Flange	GHISA / CAST IRON
F	Albero (lato pompa) / Shaft (pump face)	ACCIAIO INOX / STAINLESS STEEL

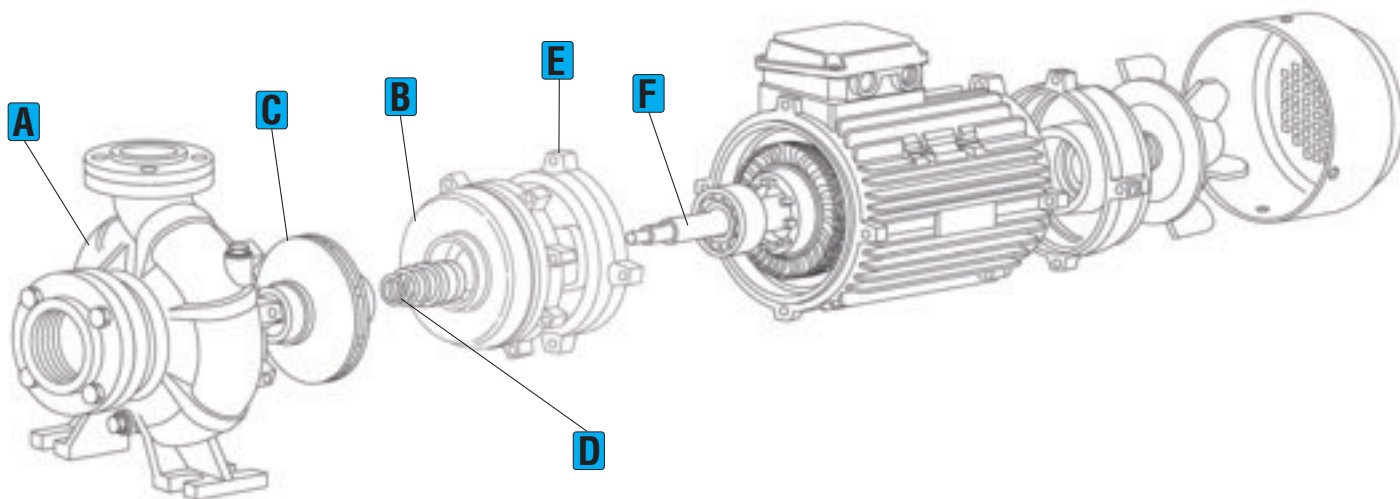



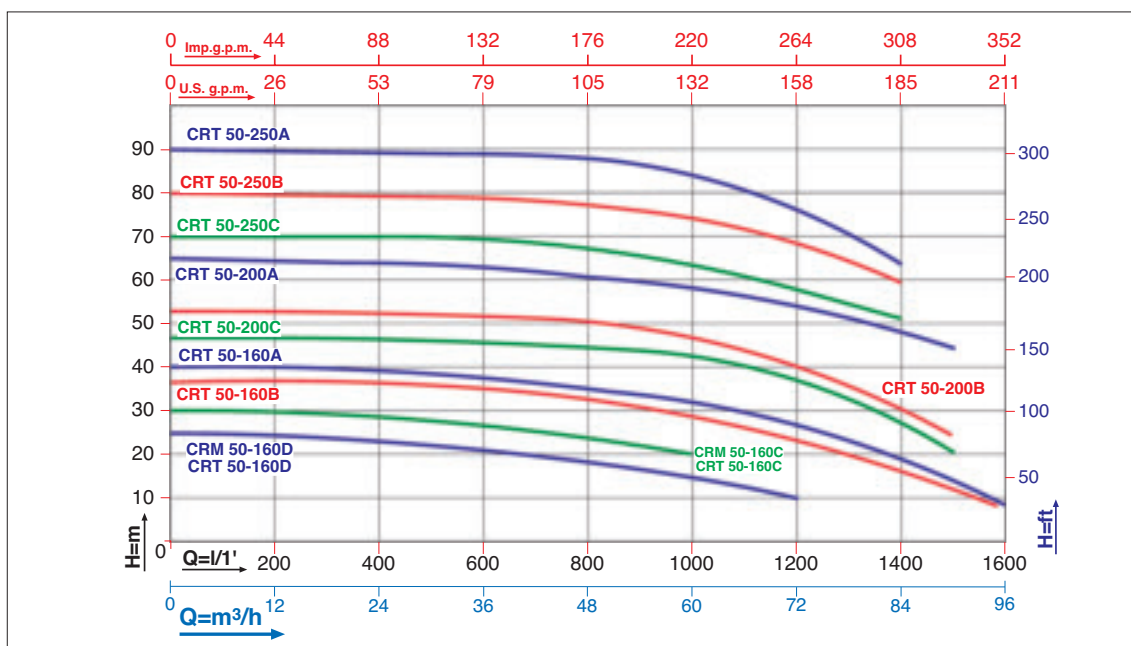
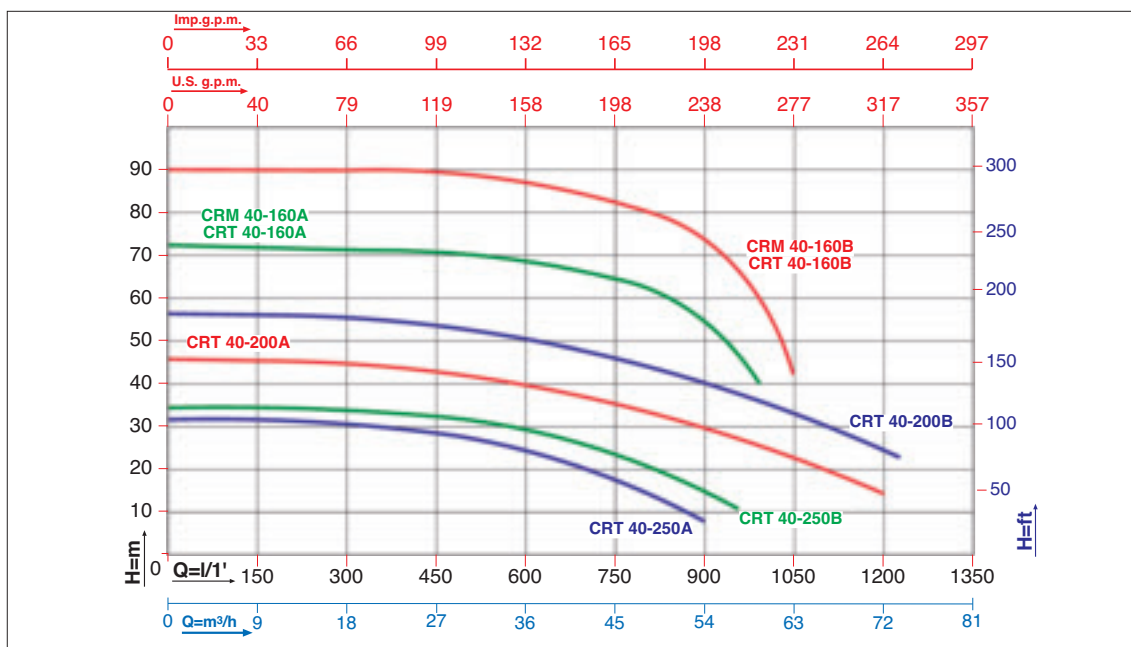
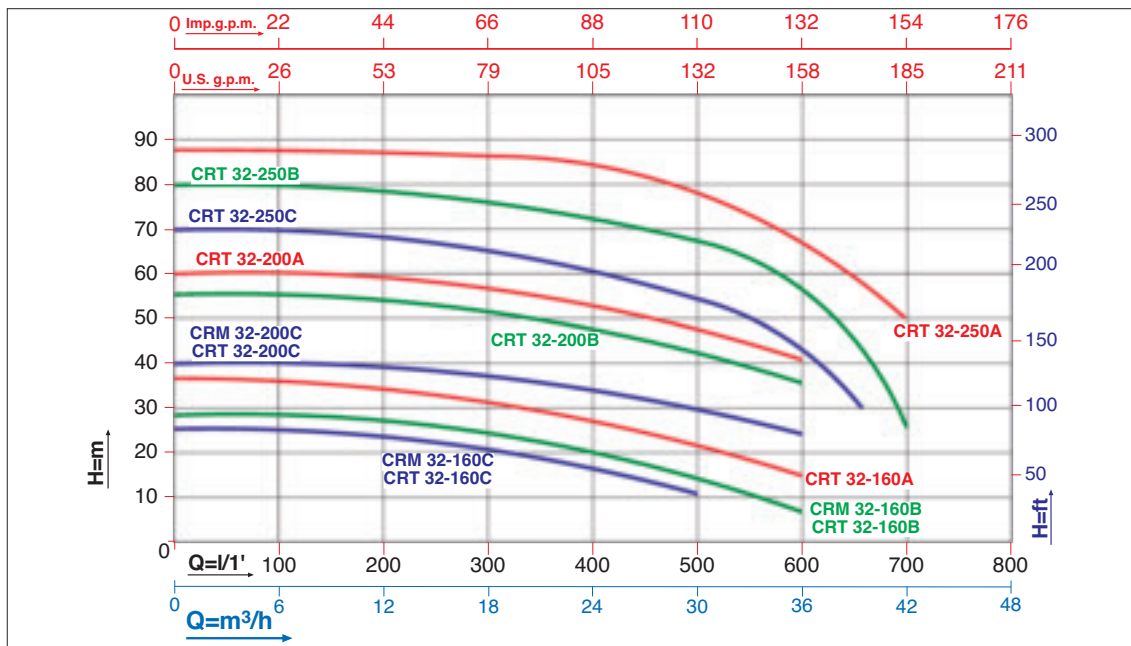

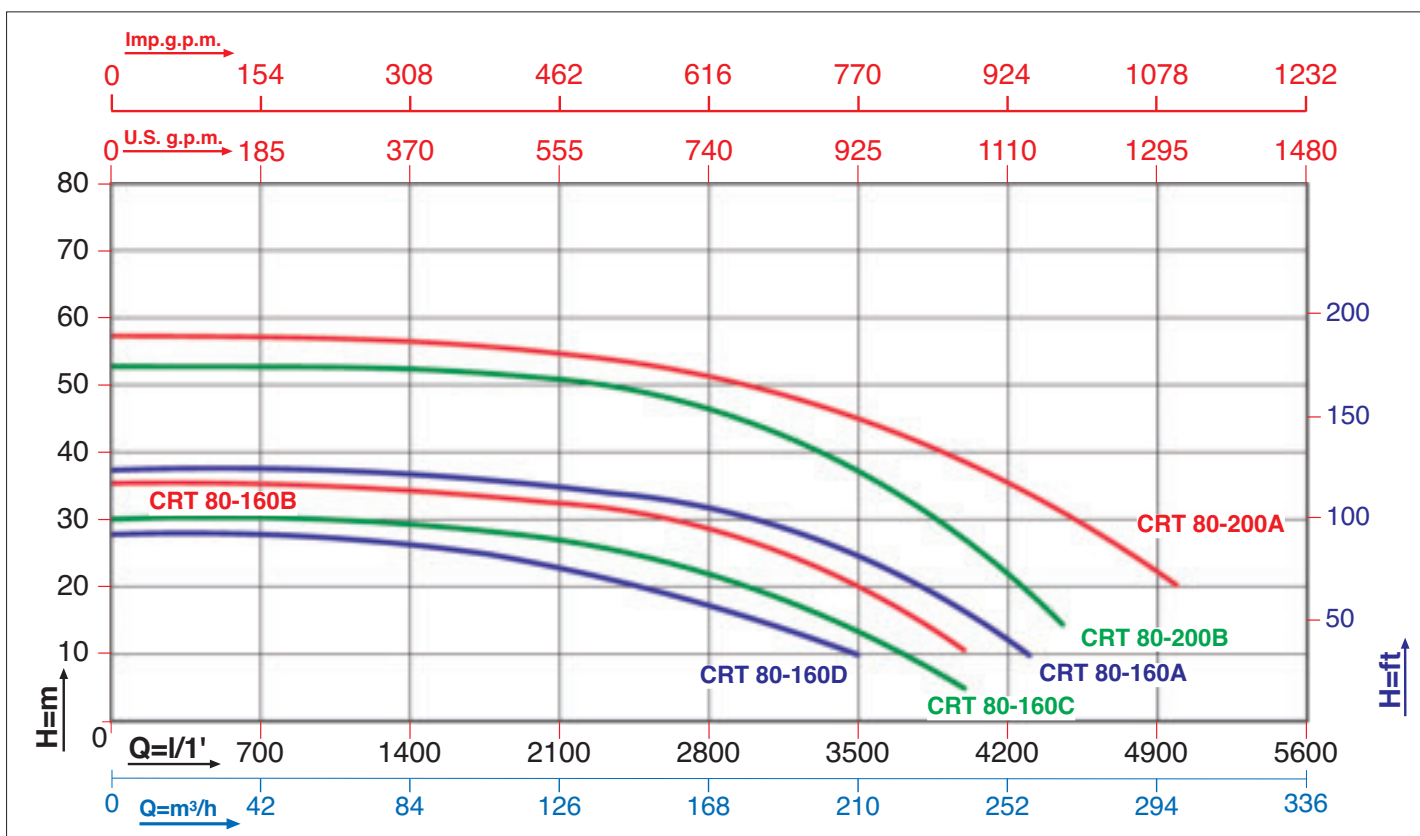
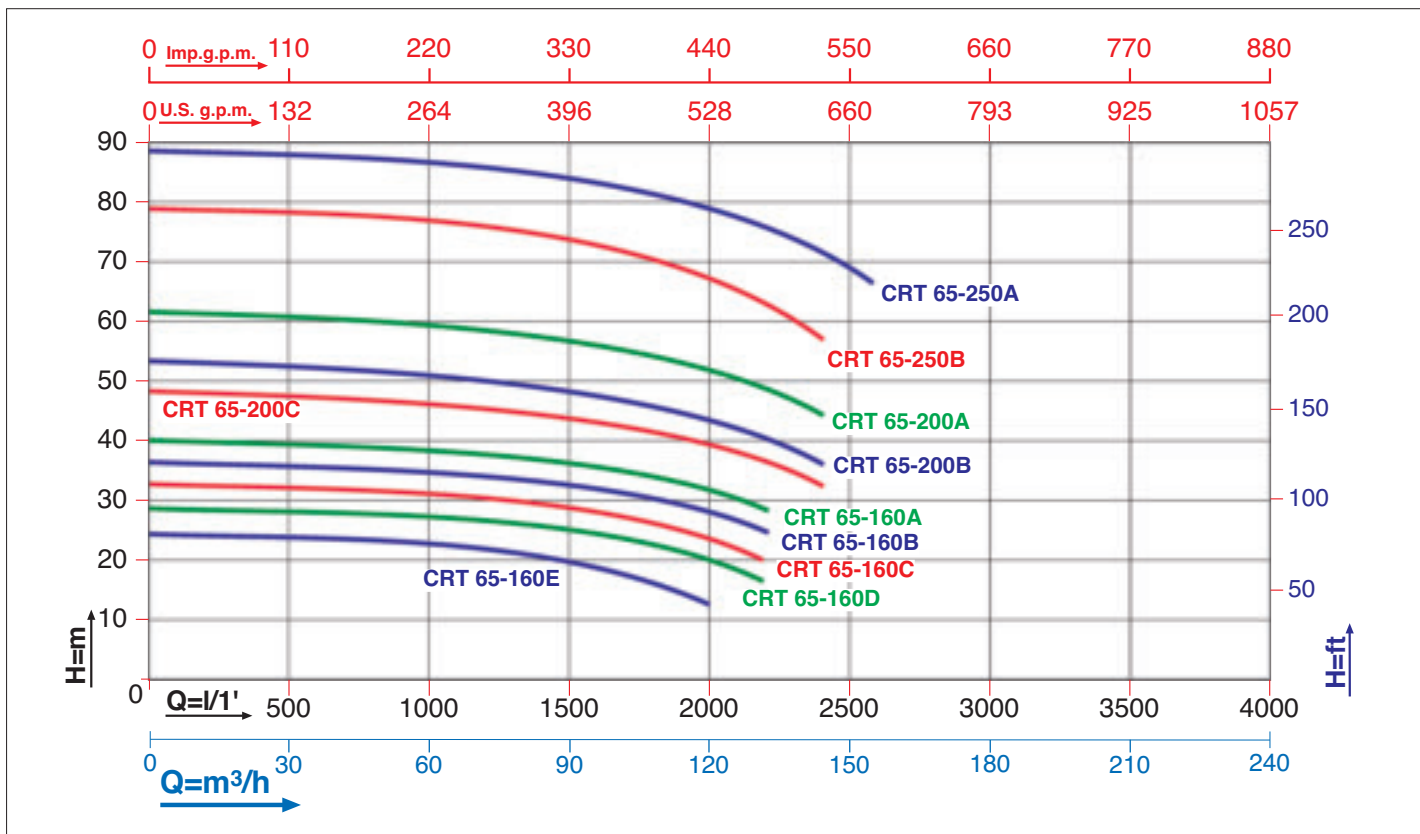

MODELLO MODEL	VOLTAGGIO VOLTAGE 50 Hz	DATI ELETTRICI / ELECTRICAL DATA						DATI IDRAULICI / HYDRAULIC DATA													
		P1 max		P2 nom.		I max	Condensatore Capacitor	m³/h													
		KW	KW	HP	Ampere	µF		VC	l/min.	100	125	150	200	250	300	350	400	450	500		
CRM 32-160 C	1 x 220-230V	2,7	1,5	2	12,0																
CRT 32-160 C	3 x 380-400V	2,7	1,5	2	4,8	---	---	25,5	25,3	25	24	23	21,5	20	18	15,5	---				
CRM 32-160 B	1 x 220-230V	3,3	2,2	3	15,0			28,8	28,5	28	27	26	24,5	23	21,5	18,5	15,5				
CRT 32-160 B	3 x 380-400V	3,3	2,2	3	5,0	---	---	28,8	28,5	28	27	26	24,5	23	21,5	18,5	15,5				
CRT 32-160 A	3 x 380-400V	4,3	3,0	4	7,0	---	---	36,5	36	35,5	34,5	33	31,5	30	28,5	26	23,5				
CRM 32-200 C	1 x 220-230V	5,7	4,0	5,5	27,0			40,7	40,5	40	39,5	39	38	36,5	35	33	31,5				
CRT 32-200 C	3 x 380-400V	5,7	4,0	5,5	8,8	---	---	40,7	40,5	40	39,5	39	38	36,5	35	33	31,5				
CRT 32-200 B	3 x 380-400V	8,6	5,5	7,5	14,0	---	---	55,7	55,5	55	54,5	54	53	51,5	50	48	46,5				
CRT 32-200 A	3 x 380-400V	9,5	7,5	10	15,0	---	---	60,7	60,5	60	59,5	58,5	57	55,5	54	52	49,5				
CRT 32-250 C	3 x 380-400V	12,0	9,2	12,5	19,0	---	---		70	69,5	68,5	67,5	66	64,5	6,5	59,5	56				
CRT 32-250 B	3 x 380-400V	13,5	11,0	15	21,5	---	---		81	80,5	79,5	78,5	77	75,5	73,5	71	67,5				
CRT 32-250 A	3 x 380-400V	15,5	15,0	20	25	---	---		90,5	90	89,5	89	87,5	86	84	81,5	78				
CRM 40-160 B	1 x 220-230V	4,8	3,0	4	22,0						32,7	32,5	32,3	32	31,5	30,5	29,5	28			
CRT 40-160 B	3 x 380-400V	4,8	3,0	4	7,5	---	---				32,7	32,5	32,3	32	31,5	30,5	29,5	28			
CRM 40-160 A	1 x 220-230V	5,7	4,0	5,5	28,0						36,2	36	35,8	35,5	35	34	33	32			
CRT 40-160 A	3 x 380-400V	5,7	4,0	5,5	8,8	---	---				36,2	36	35,8	35,5	35	34	33	32			
CRT 40-200 B	3 x 380-400V	8,6	5,5	7,5	14,0	---	---				46,5	46	45,5	45	44,5	43,5	42,5	41,5			
CRT 40-200 A	3 x 380-400V	11,3	7,5	10	17,5	---	---				56	55,5	55	54,5	54	53	52	51			
CRT 40-250 B	3 x 380-400V	15,5	11,0	15	24,5	---	---				74	73,9	73,8	73,7	73,5	73	72	71			
CRT 40-250 A	3 x 380-400V	20,0	15,0	20	32,0	---	---				91,5	91,4	91,3	91,2	91	90,5	90	89			
CRM 50-160 D	1 x 220-230V	4,8	3,0	4	22,0										25	24,5	24	23,5			
CRT 50-160 D	3 x 380-400V	4,8	3,0	4	7,5	---	---								25	24,5	24	23,5			
CRM 50-160 C	1 x 220-230V	5,7	4,0	5,5	27,0										29,5	29,2	28,8	28,3			
CRT 50-160 C	3 x 380-400V	5,7	4,0	5,5	8,8	---	---								29,5	29,2	28,8	28,3			
CRT 50-160 B	3 x 380-400V	8,2	5,5	7,5	13,2	---	---								37	36,8	36,5	36			
CRT 50-160 A	3 x 380-400V	9,5	7,5	10	15,0	---	---								40	39,8	39,5	39			
CRT 50-200 C	3 x 380-400V	12,0	9,2	12,5	19,0	---	---									48,7	48,5	48,2			
CRT 50-200 B	3 x 380-400V	13,5	11,0	15	21,5	---	---									52,7	52,5	52,2			
CRT 50-200 A	3 x 380-400V	18,0	15,0	20	29,0	---	---									64,5	64	63,5			
CRT 50-250 C	3 x 380-400V	20,0	15,0	20	32,0	---	---										71,3	71			
CRT 50-250 B	3 x 380-400V	23,0	18,5	25	36,5	---	---										80,8	80,5			
CRT 50-250 A	3 x 380-400V	27,0	22,5	30	43,0	---	---										90	89,7			
CRT 65-160 E	3 x 380-400V	8,0	5,5	7,5	13,0	---	---														
CRT 65-160 D	3 x 380-400V	10,0	7,5	10	16,0	---	---														
CRT 65-160 C	3 x 380-400V	11,5	9,2	12,5	18,5	---	---														
CRT 65-160 B	3 x 380-400V	13,5	11,0	15	21,5	---	---														
CRT 65-160 A	3 x 380-400V	16,0	15,0	20	26,0	---	---														
CRT 65-200 C	3 x 380-400V	20,0	15,0	20	32,0	---	---														
CRT 65-200 B	3 x 380-400V	23,0	18,5	25	36,5	---	---														
CRT 65-200 A	3 x 380-400V	27,0	22,5	30	43,0	---	---														
CRT 65-250 B	3 x 380-400V	37,0	30,0	40	58,0	---	---														
CRT 65-250 A	3 x 380-400V	46,0	37,0	50	72,0	---	---														
CRT 80-160 D	3 x 380-400V	12,5	11,0	15	20,5	---	---														
CRT 80-160 C	3 x 380-400V	15,0	15,0	20	24,0	---	---														
CRT 80-160 B	3 x 380-400V	18,5	18,5	25	30,0	---	---														
CRT 80-160 A	3 x 380-400V	22,0	22,5	30	35,0	---	---														
CRT 80-200 B	3 x 380-400V	33,5	30,0	40	54,0	---	---														
CRT 80-200 A	3 x 380-400V	39,0	37,0	50	62,0	---	---														

H (m)

PREVALENZA TOTALE in METRI COLONNA ACQUA / TOTAL PUMP HEAD AND WATER COLUMN HEIGHT IN m.



MODELLO MODEL	DIMENSIONI POMPA in mm / PUMP DIMENSIONS to mm														
	DNA	DNM	A	B	C	D	E	F	G	H	H1	H2	N	O	P
CRM 32-160 C	50	32	100	70	480	240	190	15	240	322	132	160	80	13,5	50
CRT 32-160 C	50	32	100	70	480	240	190	15	240	322	132	160	80	13,5	50
CRM 32-160 B	50	32	100	70	480	240	190	15	240	322	132	160	80	13,5	50
CRT 32-160 B	50	32	100	70	480	240	190	15	240	322	132	190	80	13,5	50
CRT 32-160 A	50	32	100	70	510	240	190	15	240	322	132	190	80	13,5	50
CRM 32-200 C	50	32	100	70	530	240	190	15	273	370	160	180	80	15	50
CRT 32-200 C	50	32	100	70	530	240	190	15	273	370	160	180	80	15	50
CRT 32-200 B	50	32	100	70	630	240	190	15	273	370	160	180	80	15	50
CRT 32-200 A	50	32	100	70	630	240	190	15	273	370	160	180	80	15	50
CRT 32-250 C	50	32	125	95	745	320	250	15	335	445	180	225	100	18	65
CRT 32-250 B	50	32	125	95	745	320	250	15	335	445	180	225	100	18	65
CRT 32-250 A	50	32	125	95	745	320	250	15	335	445	180	225	100	18	65
CRM 40-160 B	65	40	100	70	550	240	190	15	240	322	132	160	80	15	50
CRT 40-160 B	65	40	100	70	550	240	190	15	240	322	132	160	80	15	50
CRM 40-160 A	65	40	100	70	550	240	190	15	240	322	132	160	80	15	50
CRT 40-160 A	65	40	100	70	550	240	190	15	240	322	132	160	80	15	50
CRT 40-200 B	65	40	100	70	640	265	212	15	281	370	160	180	100	15	50
CRT 40-200 A	65	40	100	70	640	265	212	15	281	370	160	180	100	15	50
CRT 40-250 B	65	40	125	95	745	320	250	15	335	435	180	225	100	18	65
CRT 40-250 A	65	40	125	95	745	320	250	15	335	435	180	225	100	18	65
CRM 50-160 D	65	50	100	70	570	265	212	15	268	372	160	180	100	15	50
CRT 50-160 D	65	50	100	70	570	265	212	15	268	372	160	180	100	15	50
CRM 50-160 C	65	50	100	70	570	265	212	15	268	372	160	180	100	15	50
CRT 50-160 C	65	50	100	70	570	265	212	15	268	372	160	180	100	15	50
CRT 50-160 B	65	50	100	70	650	265	212	15	268	372	160	180	100	15	50
CRT 50-160 A	65	50	100	70	650	265	212	15	268	372	160	180	100	15	50
CRT 50-200 C	65	50	100	70	745	265	212	15	335	425	160	200	100	18	50
CRT 50-200 B	65	50	100	70	745	265	212	15	335	425	160	200	100	18	50
CRT 50-200 A	65	50	100	70	745	265	212	15	335	425	160	200	100	18	50
CRT 50-250 C	65	50	125	95	750	320	250	15	340	435	180	225	100	18	65
CRT 50-250 B	65	50	125	95	795	320	250	15	340	435	180	225	100	18	65
CRT 50-250 A	65	50	125	95	825	320	250	15	340	435	180	225	100	18	65
CRT 65-160 E	80	65	125	95	610	280	212	15	295	395	160	200	100	18	65
CRT 65-160 D	80	65	125	95	610	280	212	15	295	395	160	200	100	18	65
CRT 65-160 C	80	65	125	95	750	280	212	15	295	395	160	200	100	18	65
CRT 65-160 B	80	65	125	95	750	280	212	15	295	395	160	200	100	18	65
CRT 65-160 A	80	65	125	95	750	280	212	15	295	395	160	200	100	18	65
CRT 65-200 C	80	65	125	95	745	320	250	15	335	445	180	225	100	18	65
CRT 65-200 B	80	65	125	95	790	320	250	15	335	445	180	225	100	18	65
CRT 65-200 A	80	65	125	95	825	320	250	15	360	455	180	225	100	18	65
CRT 65-250 B	80	65	160	120	825	360	280	18	370	485	200	250	100	18	85
CRT 65-250 A	80	65	160	120	825	360	280	18	370	485	200	250	100	18	85
CRT 80-160 D	100	80	125	95	790	320	250	15	350	445	180	225	125	18	65
CRT 80-160 C	100	80	125	95	790	320	250	15	350	445	180	225	125	18	65
CRT 80-160 B	100	80	125	95	835	320	250	15	350	445	180	225	125	18	65
CRT 80-160 A	100	80	125	95	870	320	250	15	360	445	180	225	125	18	65
CRT 80-200 B	100	80	125	95	900	345	280	15	360	470	180	250	125	18	65
CRT 80-200 A	100	80	125	95	900	345	280	15	360	470	180	250	125	18	65



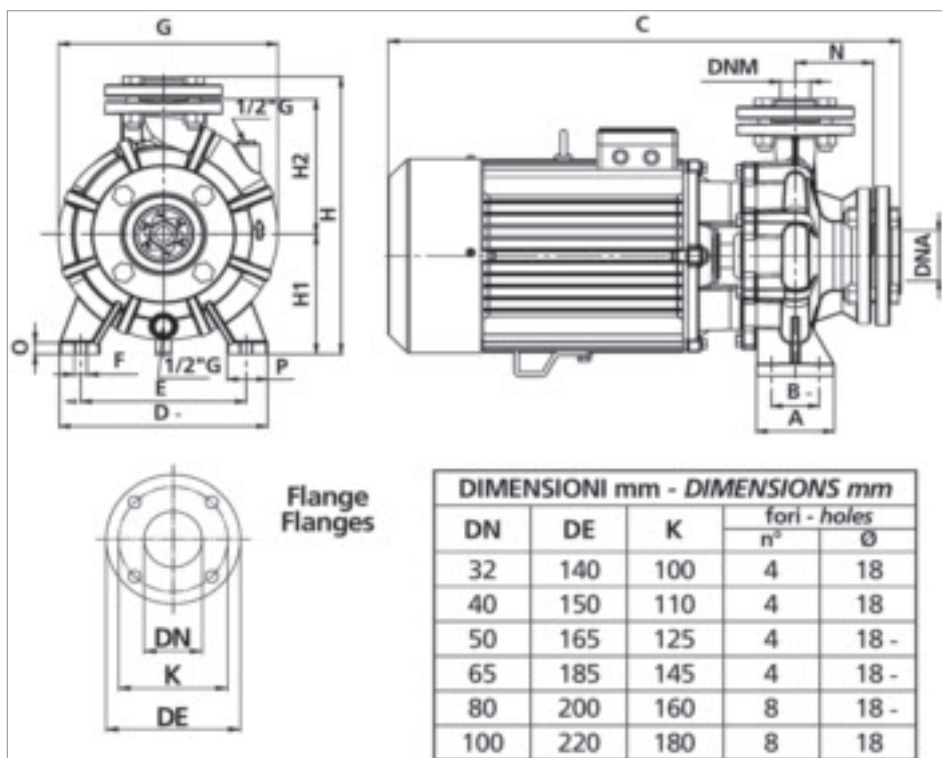
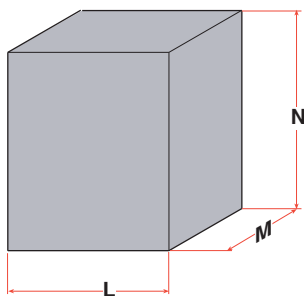

MODELLO MODEL	DIMENSIONI SCATOLA / PACKING DIMENSIONS			
	L mm	M mm	N mm	Peso / Weight Kg
CRM 32-160 C	250	520	360	36
CRT 32-160 C	250	520	360	36
CRM 32-160 B	250	520	360	39
CRT 32-160 B	250	520	360	39
CRT 32-160 A	250	520	360	42
CRM 32-200 C	300	660	390	52
CRT 32-200 C	300	660	390	52
CRT 32-200 B	300	660	390	63
CRT 32-200 A	300	660	390	69
CRT 32-250 C	355	790	455	83
CRT 32-250 B	355	790	455	90
CRT 32-250 A	355	790	455	120
CRM 40-160 B	250	560	370	47
CRT 40-160 B	250	560	370	47
CRM 40-160 A	250	560	370	50
CRT 40-160 A	250	560	370	50
CRT 40-200 B	300	660	390	65
CRT 40-200 A	300	660	390	71
CRT 40-250 B	355	790	455	91
CRT 40-250 A	355	790	455	121
CRM 50-160 D	300	660	390	50
CRT 50-160 D	300	660	390	50
CRM 50-160 C	300	660	390	60
CRT 50-160 C	300	660	390	60
CRT 50-160 B	300	660	390	65
CRT 50-160 A	300	660	390	71

MODELLO MODEL	DIMENSIONI SCATOLA / PACKING DIMENSIONS			
	L mm	M mm	N mm	Peso / Weight Kg
CRT 50-200 C	355	790	455	82
CRT 50-200 B	355	790	455	89
CRT 50-200 A	355	790	455	122
CRT 50-250 C	355	790	455	125
CRT 50-250 B	355	790	455	140
CRT 50-250 A	380	850	465	149
CRT 65-160 E	355	790	455	70
CRT 65-160 D	355	790	455	80
CRT 65-160 C	355	790	455	84
CRT 65-160 B	355	790	455	90
CRT 65-160 A	355	790	455	120
CRT 65-200 C	355	790	455	122
CRT 65-200 B	355	790	455	138
CRT 65-200 A	380	850	465	148
CRT 65-250 B	380	920	485	235
CRT 65-250 A	380	920	485	250
CRT 80-160 D	380	850	465	99
CRT 80-160 C	380	850	465	129
CRT 80-160 B	380	850	465	143
CRT 80-160 A	380	920	485	152
CRT 80-200 B	380	920	485	233
CRT 80-200 A	380	920	485	247



# PS 2 RB



## GRUPPI DI PRESSURIZZAZIONE CON POMPE BIGIRANTI (PS 2 - RB) PRESSURE SYSTEM WITH TWO IMPELLERS CENTRIFUGAL PUMPS (PS 2 - RB)

MODELLO MODEL	POTENZA / POWER		PHASE	DNA	DNM	Q max l/min	Q max l/min
	P2 (kW)	HP					
PS 2 - RB 150 M	1,1 + 1,1	1,5 + 1,5	1-PHASE	2"	1" 1/2	300	52
PS 2 - RB 200 M	1,5 + 1,5	2 + 2	1-PHASE	2"	1" 1/2	350	58
PS 2 - RB 150 T	1,1 + 1,1	1,5 + 1,5	3-PHASE	2"	1" 1/2	300	52
PS 2 - RB 200 T	1,5 + 1,5	2 + 2	3-PHASE	2"	1" 1/2	350	58
PS 2 - RB 300 T	2,2 + 2,2	3 + 3	3-PHASE	3"	2"	350	66
PS 2 - RB 400 T	3,0 + 3,0	4 + 4	3-PHASE	3"	2"	400	73,5

## GRUPPI DI PRESSURIZZAZIONE CON INVERTER (PI 2 - RB) PRESSURE SYSTEM WITH INVERTER (PI 2 - RB)

MODELLO MODEL	POTENZA / POWER		PHASE	DNA	DNM	Q max l/min	Q max l/min
	P2 (kW)	HP					
PI 2 - RB 300 T	2,2 + 2,2	3 + 3	3-PHASE	3"	2"	350	66
PI 2 - RB 400 T	3,0 + 3,0	4 + 4	3-PHASE	3"	2"	400	73,5

# PS 2 RM



**GRUPPI DI PRESSURIZZAZIONE CON POMPE MULTISTADIO (PS 2 - RM)**  
**PRESSURE SYSTEM WITH CENTRIFUGAL MULTISTAGE ELECTRIC PUMPS (PS 2 - RM)**

MODELLO MODEL	POTENZA / POWER		PHASE	DNA	DNM	Q max l/min	Q max l/min
	P2 (kW)	HP					
<b>PS 2 - RM 100 M</b>	0,75 + 0,75	1 + 1	1-PHASE	1" 1/2	1" 1/2	180	45
<b>PS 2 - RM 150 M</b>	1,1 + 1,1	1,5 + 1,5	1-PHASE	1" 1/2	1" 1/2	180	60

# GMA 0225

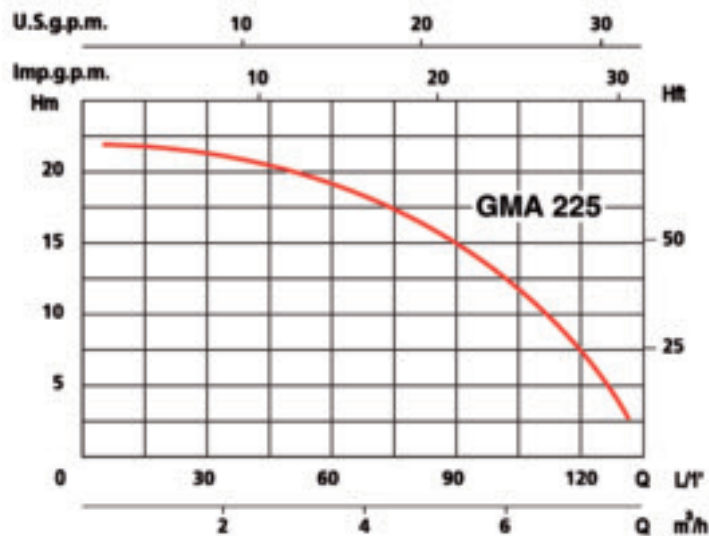

**MISCELA 5%**  
**MISCELA 5%**

### APPLICAZIONI

Motopompa autodescendente portatile, particolarmente adatta per l'approvvigionamento e la distribuzione di acque pulite e chiare in agricoltura ed in giardino dove non è possibile un collegamento elettrico.  
**Motore a scoppio 2 tempi.**

### APPLICATION

*Selfpriming hand-carry motor pumps. Particularly suitable to supply and distribute clean water for agricultural and germaning purposes, when an electrical connection is not possible.*  
**2-stroke engine.**

MODELLO MODEL	Aspirazione mandata Suction delivery	Giri/min r.p.m.	Portata max Delivery max. (l/1')	Prevalenza max. Head max. (mt)	Altezza aspirazione Suction depth (mt)	Potenza motore Motor power (HP)	Capacità serbatoio Tank Capacity (lt)	Avviamento Start system	Dimensioni Dimensions (mm)	Peso Weight (Kg)
GMA0225	25 (1")	6500	130	22	7	1,5	1	manuale recoil	400x320x300	7,8



# GMA 0425

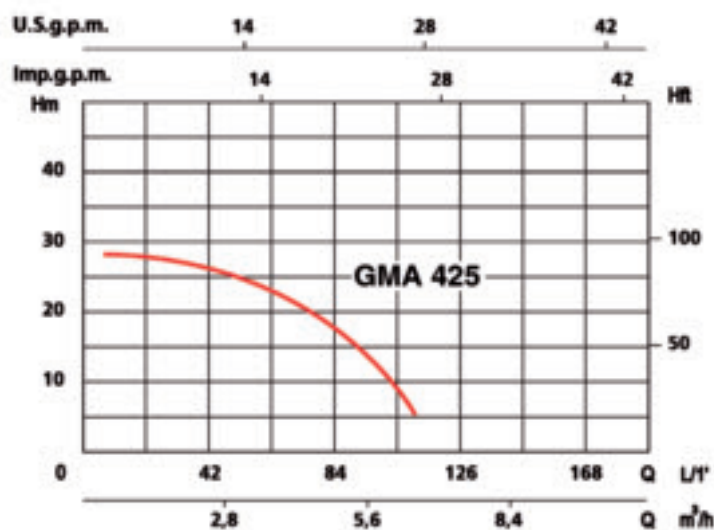

### APPLICAZIONI

Motopompa autodescante portatile, particolarmente adatta per l'approvvigionamento e la distribuzione di acque pulite e chiare in agricoltura ed in giardino dove non è possibile un collegamento elettrico.

**Motore a scoppio 4 tempi.**

### APPLICATION

Selfpriming hand-carry motor pumps. Particularly suitable to supply and distribute clean water for agricultural and germaning purposes, when an electrical connection is not possible.

**4-stroke engine.**

MODELLO MODEL	Aspirazione mandata Suction delivery	Giri/min r.p.m.	Portata max Delivery max. (l/1')	Prevalenza max. Head max. (mt)	Altezza aspirazione Suction depth (mt)	Potenza motore Motor power (HP)	Capacità serbatoio Tank Capacity (lt)	Avviamento Start system	Dimensioni Dimensions (mm)	Peso Weight (Kg)
GMA0425	25 (1")	6500	110	28	7	1,5	1	manuale recoil	405x250x350	8,7

# GMA 0430

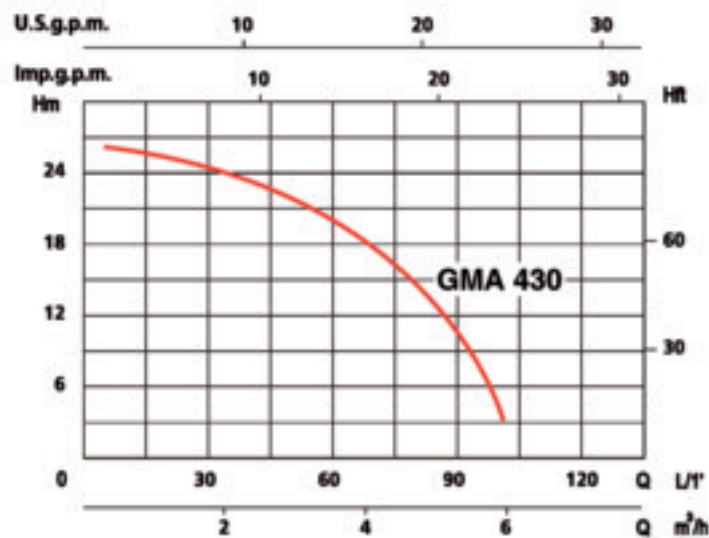

### APPLICAZIONI

Motopompa autodescendente portatile, particolarmente adatta per l'approvvigionamento e la distribuzione di acque pulite e chiare in agricoltura ed in giardino dove non è possibile un collegamento elettrico.  
**Motore a scoppio 4 tempi.**

### APPLICATION

Selfpriming hand-carry motor pumps. Particularly suitable to supply and distribute clean water for agricultural and germaning purposes, when an electrical connection is not possible.  
**4-stroke engine.**

MODELLO MODEL	Aspirazione mandata Suction delivery	Giri/min r.p.m.	Portata max Delivery max. (l/1')	Prevalenza max. Head max. (mt)	Altezza aspirazione Suction depth (mt)	Potenza motore Motor power (HP)	Capacità serbatoio Tank Capacity (lt)	Avviamento Start system	Dimensioni Dimensions (mm)	Peso Weight (Kg)
GMA0430	25 (1")	3600	100	26	7	2,5	1	manuale recoil	400x320x420	17,0



# GMA 0440

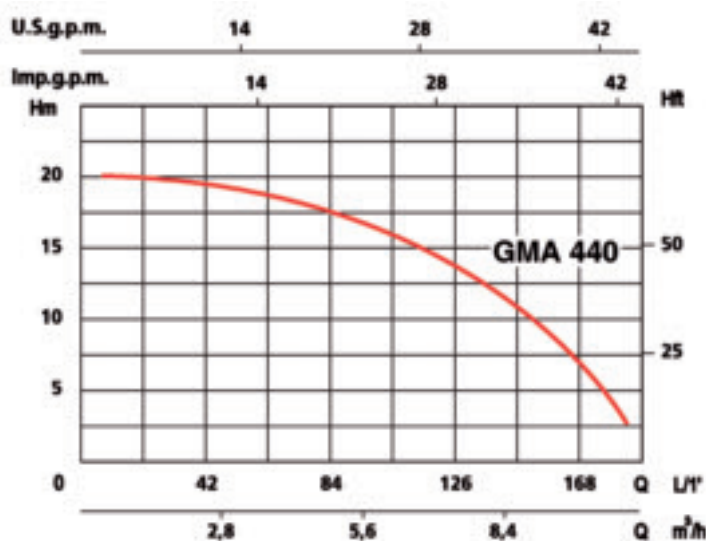

### APPLICAZIONI

Motopompa autodescendente portatile, particolarmente adatta per l'approvvigionamento e la distribuzione di acque pulite e chiare in agricoltura ed in giardino dove non è possibile un collegamento elettrico.

**Motore a scoppio 4 tempi.**

### APPLICATION

Selfpriming hand-carry motor pumps. Particularly suitable to supply and distribute clean water for agricultural and germaning purposes, when an electrical connection is not possible.

**4-stroke engine.**

MODELLO MODEL	Aspirazione mandata Suction delivery	Giri/min r.p.m.	Portata max Delivery max. (l/1')	Prevalenza max. Head max. (mt)	Altezza aspirazione Suction depth (mt)	Potenza motore Motor power (HP)	Capacità serbatoio Tank Capacity (lt)	Avviamento Start system	Dimensioni Dimensions (mm)	Peso Weight (Kg)
GMA0440	40(1" 1/2)	3600	180	20	7	2,5	1	manuale recoil	350x320x420	15,0



# K



## APPLICAZIONI

- Queste pompe sono idonee per il maneggio di liquidi chiari e leggeri, come ad esempio l'acqua, la benzina, il diesel e tutti i carburanti, il petrolio combustibile, l'alcohol, soluzioni chimiche leggere, l'olio da cucina, ecc., e sono le uniche pompe a mano sicure per il maneggio di liquidi bollenti - fino a una temperatura di 80° C (176° F).

## APPLICATIONS

- *These pumps are suitable for the handling of clear and light liquids such as water, petrol, diesel and all fuels, paraffin, alcohol, light chemical solutions, edible oils etc. and are the only hand pumps safe for use with very hot liquids - up to 80°C (176°F)*

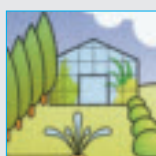

**AV ARVEN**

**Funzionamento:**

Le pompe vengono messe in funzione dal movimento di una manovella, che causa la rotazione a semicerchio dentro la pompa, dell'asse e del pistone alato, equipaggiato di valvole a cerniera. Inoltre, racchiuso nel rivestimento della pompa c'è il divisore (o distributore) di aspirazione, equipaggiato di linguette. La tenuta a baderna, compressa dall'anello e dal dado, agisce come chiusura ermetica tra l'asse e il rivestimento della pompa. Il modello standard ha le flange filettate ed è provvisto pure di controflange filettate.

**Caratteristiche costruttive:**

Corpo: in ghisa  
 Parti interne: in ottone  
 Manovella: in acciaio  
 Tenuta a baderna: in corda di grafite morbida

- il corpo interno affusolato - questo vantaggio tecnologico, unico della pompa K, assicura il posizionamento automatico delle pale nel corpo e garantisce un funzionamento efficiente e senza problemi anche dopo anni di uso;
- un tappo antigelo - permette all'acqua di essere scaricata se c'è rischio di gelo;
- controllo completo di qualità - ogni pompa vienemessa alla prova individualmente con un'altezza d'aspirazione di 7 metri di acqua e un'altezza di mandata di 20 metri.

**Operation of the pump:**

The pumps are operated by the movement of the handle wich causes the shaft and the wing piston, fitted with flap valves, to semi-rotate within the pump. Also enclosed in the body of the pump is the suction divider, fitted with flaps. Gland packing compressed by the gland ring and nut acts as a seal between the shaft and the pump cover. The standard model has threaded flanges and is supplied with threaded counter flanges. Two lugs facilitate the mounting of the pump to a wall or similar structure.

**Features:**

Casing: Cast iron  
 Internals: Brass  
 Shaft: Steel  
 Gland Packing: Soft graphite cord

- The tapered internal body - this unique technological advantage assures automatic settlement of the wings in the body and guarantees smooth efficient operation aven after years of usage
- A frost plug - allows water to be drained if there is a risk of frost
- Thorough quality control - each pump is individually tested to a suction lift of 7 m of water and 20 m of delivery head.

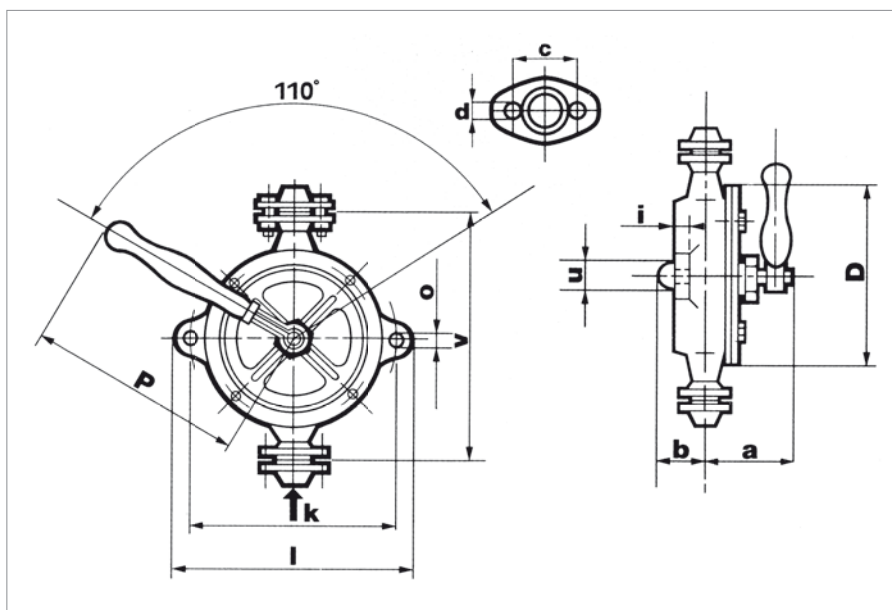

Tipo Type	Dimensioni mm Dimensions mm													KG
	DNM DNA	a	b	c	d	i	k	l	o	P	u	v	D	
KPM 0300	1/2"	140	55	55	9,5	10	130	160	13	300	25	175	135	4
KPM 0400	3/4"	140	55	65	9,5	10	150	180	13	300	25	205	150	6
KPM 0500	1"	145	60	75	9,5	10	170	200	13	360	30	230	170	8
KPM 0600	1. 1/4"	170	62	90	14	12	200	240	13	450	30	275	200	10

TIPO TYPE	DIAMETRO TUBI CASING INNER SIMENSIONS	PORTATA DEBIT	PREVALENZA HEAD	ASPIRAZIONE MAX MAX. DEPTH OF WELL	
KPM0300	1/2"	14	11,50	25	7 mt
KPM0400	3/4"	19	17,25	25	7 mt
KPM0500	1"	25	22,50	25	7 mt
KPM0600	1"1/4	32	29	22	7 mt

# NP



## APPLICAZIONI

- Le pompe ad azionamento manuale del tipo NP sono utilizzate principalmente per pozzi freatici, perforati e scavati con una profondità non superiore a 7 metri. Costituiscono il tipo più piccolo ed economico di pompe per pozzi domestici. La pompa NP viene utilizzata in ambiente domestico per pompare acqua potabile da bere o sanitaria priva di solidi sospesi duri, con una temperatura non superiore a 40°C. Si raccomanda di usare le pompe in luoghi in cui non vi sia pericolo che l'acqua geli nel corpo, per es. in un corridoio o in una cantina. Se la pompa è installata all'aperto, è necessario smontarla per l'inverno o proteggerla perfettamente contro il gelo.

## APPLICATIONS

- *The NP pump is used in households for pumping drinking or service water without hard suspended solids, of a temperature of not more than 40°C. It is recommended to use the pumps in such localities where there is no danger of the water freezing in the casing, e.g. in a corridor or in a cellar. If the pump is installed out-of-door, it is necessary to dismount it for the winter or to protect it perfectly against freezing.*

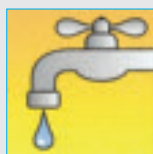
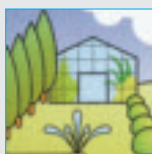

**AV ARVEN**

**Funzionamento:**

La modalità di funzionamento della pompa a semplice effetto NP è tale che l'acqua viene aspirata sotto il pistone da una corsa verso l'alto del pistone. Durante l'altro movimento del pistone nella posizione di fondo, l'acqua va sopra al pistone mediante il sollevamento di una valvola e passa attraverso un'uscita della pompa. Durante una corsa la pompa aspira e solleva l'acqua, durante l'altra corsa gira a vuoto. Questo ciclo viene ripetuto costantemente durante il pompaggio.

**Caratteristiche costruttive:**

Il corpo di supporto con l'uscita, il tappo imperniato, la trave di contrappeso, la piastra i pezzi del pistone e il filtro di aspirazione sono in ghisa. Il tirante del pistone e i pezzi di giunzione sono in acciaio.

**Operation of the pump:**

The NP single-acting pump works so that is sucked under the piston by one upward stroke of the piston. During the other movement of the piston into the bottom position the water gets above the piston by the lifting of a valve and flows out through an outlet from the pump. During one stroke the pump sucks and lifts the water, during the other stroke it idles. This cycle is constantly repeated during pumping.

**Features:**

The stand body with the outlet, the pivoted cap, the balance beam, the plate, the piston parts and the suction strainer are of cast iron. The piston tie-rod and the joining parts are of steel.

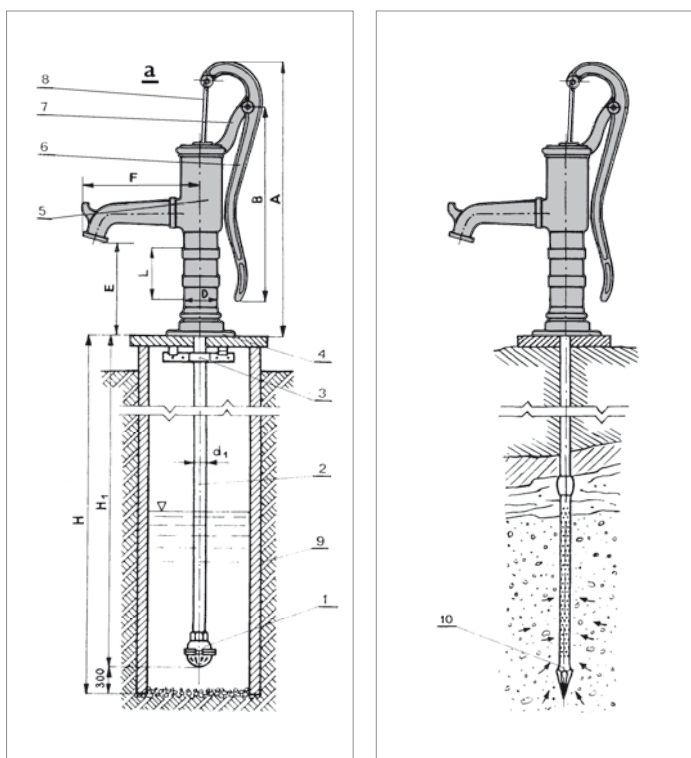

Tipo Type	Dimensioni mm Dimensions mm						
	A	B	D	d1	E	F	L
<b>NP</b>	674	520	75	1.1/4"	237	295	160

TIPO TYPE	DIAMETRO TUBI CASING INNER DIMENSIONS		PORTATA DEBIT	PREVALENZA HEAD	ASPIRAZIONE MAX MAXIMUM DEPTH OF WELL	PESO WEIGHT
<b>NPM0600</b> CON ZANCHE A MURO	1.1/4"	32 mm	28 L/min.	30	7 mt	17 Kg
<b>NPM0650</b> CON BASE	1.1/4"	32 mm	28 L/min.	30	7 mt	17 Kg

# ACCESSORI - ACCESSORIES



## GALLEGGIANTE FLOATER

CODICE CODE	MISURA SIZE
0786.TGR 0800.00	5 MT
0786.TGR 1000.00	10 MT
0786.TGR 1500.00	20 MT
0787.TGR 0800.00 OPTIONAL CONTRAPPESO CONTER WEIGHT	



## QUADRO ELETTRICO MONOFASE PER ELETTROPOMPE SOMMERGIBILI SINGLE-PHASE CONTROL BOARD FOR SUBMERSIBLE ELECTRIC PUMPS

CODICE-CODE	POTENZA MOTORE-POWER		CONDENSATORE-CAPACITOR
	kW	Hp	450 V x MF
0724 KNG 1500.00	1,1	1,5	40
0724 KNG 2000.00	1,5	2	50
0724 KNG 3000.00	2,2	3	80
COMPONENTI		COMPONENTS	
<ul style="list-style-type: none"> <li>• CASSETTA IN PLASTICA</li> <li>• RELÈ PER COMANDO GALLEGGIANTE</li> <li>• CONDENSATORE</li> <li>• INTERRUTTORE AUTOMATICO / MANUALE</li> <li>• PROTETTORE TERMICO CON RIARMO MANUALE</li> <li>• CLASSE DI PROTEZIONE IP54</li> </ul>		<ul style="list-style-type: none"> <li>• PLASTIC BOX</li> <li>• FLOATING CONTROL RELAY</li> <li>• CAPACITOR</li> <li>• ON / OFF SWITCH</li> <li>• THERMIC PROTECTOR - MANUAL RESET</li> <li>• IP55 INSULATION CLASS</li> </ul>	



## QUADRO ELETTRICO TRIFASE PER ELETTROPOMPE SOMMERGIBILI THREE-PHASE CONTROL BOARD FOR SUBMERSIBLE ELECTRIC PUMPS

CODICE-CODE	POTENZA MOTORE-POWER		A	Volt
	kW	Hp		
0726 KTC 6000.00	1,1÷4,5	1,5÷6	1÷20	400
COMPONENTI		COMPONENTS		
<ul style="list-style-type: none"> <li>• CASSETTA IN PLASTICA ISOLANTE COMPLETA DI TELERUTTORE</li> <li>• COMMUTATORE MANUALE/AUTOMATICO</li> <li>• PULSANTE DI RELÈ TERMICO</li> <li>• SPINA A 3 POLI + N + T</li> <li>• CLASSE DI PROTEZIONE IP54</li> <li>• FUSIBILI GENERALI</li> <li>• TRASFORMATORI AMPEROMETRICI</li> <li>• INTERRUTTORE DI MANOVRA - SEZIONATORE BLOCCAPORTA</li> </ul>		<ul style="list-style-type: none"> <li>• PLASTIC BOX</li> <li>• REMOTE CONTROL SWITCH</li> <li>• ON / OFF SWITCH</li> <li>• THERMIC PROTECTOR</li> <li>• MANUAL RESET</li> <li>• 3 POLES + N + T PLUG</li> <li>• IP55 INSULATION CLASS</li> <li>• GENERAL FUSES</li> <li>• AMMETTER TRANSFORMER</li> <li>• WORKING SWITCH - DOOR-LOCKING SWITCH</li> </ul>		

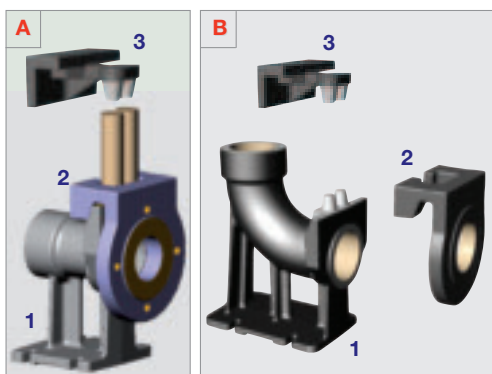

CODICE-CODE	MISURA-SIZE
0317.TGF 1000.00	<b>A</b> - Kit scivolo di discesa a 2 tubi guida (DN 50) completo di: <i>Kit guide rail complete of:</i>
0317.TGF 1001.00 0317.TGF 1002.00 0317.TGF 1003.00	1 - Base-Base 2 - Aggancio flangiato-Flange coupling 3 - Supporto tubi di discesa-Pipe support
0317.TGF 2000.00	<b>B</b> - Kit scivolo di discesa a 2 tubi guida (DN 80) completo di: <i>Kit guide rail complete of:</i>
0317.TGF 3000.00 0317.TGF 4000.00 0317.TGF 6000.00	1 - Base-Base 2 - Aggancio flangiato-Flange coupling 3 - Supporto tubi di discesa-Pipe support



# ACCESSORI - ACCESSORIES



**VALVOLA DI RITEGNO IN ACCIAIO INOX (AISI 304)**  
**CHECK VALVE IN STAINLESS STEEL (AISI 304)**

CODICE-CODE	MISURA-SIZE
ADF. 063.03	1/2"
ADF. 063.04	3/4"
ADF. 063.05	1"
ADF. 063.06	1" 1/4
ADF. 063.07	1" 1/2
ADF. 063.08	2"



**VALVOLA DI RITEGNO IN ACCIAIO INOX (AISI 304) COMPLETA DI FILTRO**  
**CHECK VALVE IN STAINLESS STEEL (AISI 304) COMPLETE WITH FILTER**

CODICE-CODE	MISURA-SIZE
ADF. 064.03	1/2"
ADF. 064.04	3/4"
ADF. 064.05	1"
ADF. 064.06	1" 1/4
ADF. 064.07	1" 1/2
ADF. 064.08	2"



**RACCORDO SIMMETRICO RAPIDO CON FILETTATURA MASCHIO IN ALLUMINIO**  
**ADAPTERS WITH MALE THREAD IN ALLUMINIUM**

CODICE-CODE	MISURA-SIZE
0663.KTC1500.00	1" 1/2
0663.KTC2000.00	2"
0663.KTC4000.00	3"

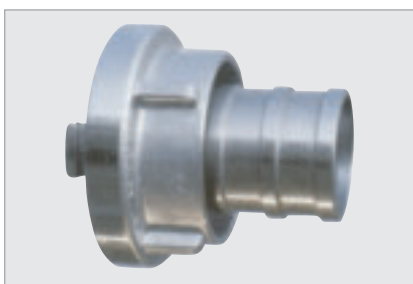

**RACCORDO SIMMETRICO RAPIDO CON PORTAGOMMA IN ALLUMINIO**  
**SUCTION HOSE COUPLING IN ALLUMINIUM**

CODICE-CODE	MISURA-SIZE
0662.KTC1500.00	1" 1/2
0662.KTC2000.00	2"
0662.KTC4000.00	3"



**RACCORDO PORTAGOMMA IN OTTONE 3 PEZZI**  
**THREE PIECES HOSE CONNECTOR BRASS**

CODICE-CODE	MISURA-SIZE
ADF.205.04X20	RACCORDO PORTAGOMMA 3PZ DIRITTO 3/4" x 20 HOSE CONNECTOR STRAIGHT 3 PCS 3/4" x 20
ADF.205.04X25	RACCORDO PORTAGOMMA 3PZ DIRITTO 3/4" x 25 HOSE CONNECTOR STRAIGHT 3 PCS 3/4" x 25
ADF.205.05X25	RACCORDO PORTAGOMMA 3PZ DIRITTO 1" x 25 HOSE CONNECTOR STRAIGHT 3 PCS 1" x 25
ADF.205.05X30	RACCORDO PORTAGOMMA 3PZ DIRITTO 1" x 30 HOSE CONNECTOR STRAIGHT 3 PCS 1" x 30
ADF.205.07X40	RACCORDO PORTAGOMMA 3PZ DIRITTO 1" 1/2 x 40 HOSE CONNECTOR STRAIGHT 3 PCS 1" 1/2 x 40
ADF.225.05X25	RACCORDO PORTAGOMMA 3PZ CURVO 1" x 25 HOSE CONNECTOR STRAIGHT 3 PCS 1" x 25



# ACCESSORI - ACCESSORIES



**VALVOLA DI FONDO IN OTTONE**  
**CHECK VALVE IN BRASS**

CODICE-CODE	MISURA-SIZE
ADF. 010.03	1/2"
ADF. 010.04	3/4"
ADF. 010.05	1"
ADF. 010.06	1" 1/4
ADF. 010.07	1" 1/2
ADF. 010.08	2"



**VALVOLA DI RITEGNO IN OTTONE**  
**CHECK VALVE IN BRASS**

CODICE-CODE	MISURA-SIZE
ADF. 005.03	1/2"
ADF. 005.04	3/4"
ADF. 005.05	1"
ADF. 005.06	1" 1/4
ADF. 005.07	1" 1/2
ADF. 005.08	2"

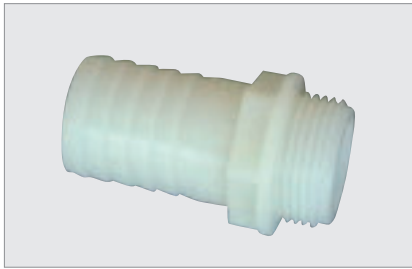

**RACCORDO PORTAGOMMA DRITTO FILETTATO IN POLIAMMIDE (PA-NYLON)**  
**STRAIGHT HOSE NOZZLE THREADED (PA-NYLON)**

CODICE-CODE	MISURA-SIZE	CONFEZIONE-PARCELLING
0361.RGL0300.00	1"	10 PEZZI / PIECES
0361.RGL0400.00	1" 1/4	10 PEZZI / PIECES
0371.ALK0800.00	1" 1/2	5 PEZZI / PIECES
0371.SKP1000.00	2"	5 PEZZI / PIECES



**RACCORDO PORTAGOMMA CURVO MASCHIO (P.P)**  
**ELBOW HOSE NOZZLE (P.P)**

CODICE-CODE	MISURA-SIZE	CONFEZIONE-PARCELLING
0371.AVX0800.00	1" 1/2 (DN40)	5 PEZZI / PIECES
0371.AVX1000.00	2" (DN50)	5 PEZZI / PIECES



**KIT D'ASPIRAZIONE DA 1"**  
**1" SUCTION KIT**

CODICE-CODE	MISURA-SIZE
/KIT.ASPIRAZ.00	TUBO 4MT CON VALVOLA DI FONDO 4MT HOSE WITH FOOT VALVE

# ACCESSORI - ACCESSORIES



## REGOLATORE DI PRESSIONE CON MANOMETRO PER ELETTROPOMPE PRESSURE REGULATOR FOR ELECTRIC PUMPS

CODICE CODE	TENS. DI ALIMENTAZ. INPUT VOLTAGE	INTENSITA' MAX INTENSITY MAX	INDICE DI PROT. PROTECTION RATING
0789.PRESC2C.00	220-240 V	16A	IP 65
	PRESSIONE MAX DI ESERCIZIO MAXIMUM WORKING PRESSURE	TEMP. MAX DI ESERCIZIO MAXIMUM TEMP. PRESSURE	ATTACCO (MASCHIO) CONNECTION (MALE)
	10 bar	35°C	1"



## REGOLATORE DI PRESSIONE CON MANOMETRO PER ELETTROPOMPE (CON RISERVA D'ACQUA) PRESSURE REGULATOR WITH MANOMETER FOR ELECTRIC PUMPS (WITH RESERVE WATER)

CODICE CODE	TENS. DI ALIMENTAZ. INPUT VOLTAGE	INTENSITA' MAX INTENSITY MAX	INDICE DI PROT. PROTECTION RATING
0789.PRESC2P.00	220-240 V	16A	IP 65
	PRESSIONE MAX DI ESERCIZIO MAXIMUM WORKING PRESSURE	TEMP. MAX DI ESERCIZIO MAXIMUM TEMP. PRESSURE	ATTACCO (MASCHIO) CONNECTION (MALE)
	10 bar	35°C	1"



## SET IDROSFERA 24 LITRI 24 LITERS TANK GROUP

CODICE CODE	COMPONENTI COMPONENTS
0718.JTX0710.00	<ul style="list-style-type: none"> <li>SERBATOIO 24 LT VERTICALE - VERTICAL TANK 24 LT</li> <li>MANOMETRO SCALA 0-6 BAR - PRESSURE GAUGE</li> <li>RACCORDO OTTONE 5 VIE - 5 WAYS CONNECTOR</li> <li>PRESSOSTATO - PRESSURE SWITCH</li> </ul>



## IDROSFERA 24 LITRI A MEMBRANA 24 LITERS MEMBRANE PRESSURE TANK

CODICE CODE	PRESSIONE MAX MAX PRESSURE	CAPACITA' LITRI CAPACITY LITERS	RACCORDO CONNECTOR
0212.JTL1000.00	8 bar	24	1"



## IDROSFERA ORIZZONTALE 22 LITRI 22 LITERS HORIZONTAL PRESSURE TANK

CODICE CODE	PRESSIONE MAX MAX PRESSURE	CAPACITA' LITRI CAPACITY LITERS	RACCORDO CONNECTOR
0212.JTL1005.00	8 bar	22	1"



## SET IDROSFERA ORIZZONTALE LT 22 22 LITERS HORIZONTAL TANK GROUP

CODICE CODE	COMPONENTI COMPONENTS
0718.JTL1005.00	<ul style="list-style-type: none"> <li>SERBATOIO 22 LT ORIZZONTALE - HORIZONTAL TANK 22 LT</li> <li>MANOMETRO SCALA 0-6 BAR - PRESSURE GAUGE</li> <li>RACCORDO OTTONE 5 VIE - 5 WAYS CONNECTOR</li> <li>PRESSOSTATO - PRESSURE SWITCH</li> <li>TUBO FLESSIBILE - FLEXIBLE HOSE</li> </ul>

# ACCESSORI - ACCESSORIES



**PRESSOSTATO**  
*PRESSURE SWITCH*

CODICE CODE	MISURA SIZE	RACCORDO CONNECTOR
0790.RMC1000.00	1,4÷2,8 BAR	1/4" FEMMINA/FEMALE



**MANOMETRO ATTACCO RADIALE**  
*PRESSURE GAUGE RADIAL ATTACK*

CODICE CODE	MISURA SIZE	RACCORDO CONNECTOR
0667.JTL1000.00	Ø 50	1/4"



**TUBO FLESSIBILE 600mm**  
*FLEXIBLE HOSE 600mm*

CODICE-CODE	MISURA-SIZE
0667.JTG1000.00	600mm



**RACCORDO OTTONE**  
*BRASS CONNECTOR*

CODICE-CODE	MISURA-SIZE
ADF .375.05	A 5 VIE 5 WAYS 1"



**QUADRO ELETTRICO PER MOTORI SOMMERSI 4" MONOFASE**  
*CONTROL BOARD FOR SINGLE PHASE 4 INCH WELLS SUBMERSED MOTOR*

CODICE CODE	MISURA SIZE
0726.OPM0500.00	HP 0,5 - µF 20
0726.OPM0750.00	HP 0,75 - µF 25
0726.OPM1000.00	HP 1,0 - µF 35
0726.OPM1500.00	HP 1,5 - µF 40
0726.OPM2000.00	HP 2,0 - µF 50
0726.OPM3000.00	HP 3,0 - µF 80
0726.OPM5000.00	CONTROL BOX - CONDENSATORE DA 125µF (30A) CONTROL BOARD - CAPACITOR 125µ (30A) HP 5,5

# ACCESSORI PER STAZIONI DI SOLLEVAMENTO (SERIE BOX) ACCESSORIES FOR LIFTING STATIONS (BOX SERIES)



**KIT ALLARME**  
*FLASHING SOUND SIGNAL KIT*

CODICE-CODE	COMPONENTI-COMPONENTS
0719.BOX0102.00	KIT ALLARME ACUSTICO VISIVO PER QUADRO MONOFASE/TRIFASE SOUND SIGNAL WITH FLASHING SIGNAL KIT FOR SINGLE-PHASE/TRHEE-PHASE



**QUADRO ELETTRICO (BOX-1)**  
*CONTROL BOARD (BOX-1)*

CODICE-CODE	COMPONENTI-COMPONENTS
0719.BOX100M.00 (MONOFASE - SINGLE-PHASE)	QUADRO ELETTRICO PER POMPA. COMPLETO DI CASSA IN MATERIALE PLASTICO IP54, TERMICI RIARMABILI, FUSIBILI, INTERRU- TORE GENERALE BLOCCAPORTA, MORSETTIERA INTERRUPTORE ON/OFF, SPIE DI FUNZIONAMENTO E BLOCCO.
0719.BOX100T.00 (TRIFASE - THREE-PHASES)	CONTROL BOARD FOR SINGLE PUMP WITH PLASTIC BOX IP54, RELAIED THERMICS, FUSES, WORKING SWITCH/DOOR-LOCKING SWITCH, TERMIN- AL BOX ON/OFF SWITCH, START/STOP LIGHTS.



**QUADRO ELETTRICO (BOX-2)**  
*CONTROL BOARD (BOX-2)*

CODICE-CODE	COMPONENTI-COMPONENTS
0719.BOX200M.00 (MONOFASE - SINGLE-PHASE)	QUADRO ELETTRICO PER DUE POMPE, COMPLETO DI CASSA IN MATE- RIALE PLASTICO IP54, TERMICI RIARMABILI, FUSIBILI, INTERRUPTORE GENERALE BLOCCAPORTA, MORSETTIERA INTERRU- TORE ON/OFF, SPIE DI FUNZIONAMENTO E BLOCCO, ALTERNANZA AUTO- MATIC PER AVVIAMENTI ALTERNI.
0719.BOX200T.00 (TRIFASE - THREE-PHASES)	CONTROL BOARD FOR TWO PUMPS WITH PLASTIC BOX IP54, RELAIED THERMICS, FUSES, WORKING SWITCH/DOOR LOCKING SWITCH, TERMIN- AL BOX ON/OFF SWITCH, START/STOP LIGHTS, AUTOMATIC ALTERNA- TION FOR ALTERNATE STARTINGS.



**GALLEGGIANTE**  
*FLOATER*

CODICE-CODE	MISURA-SIZE
0786.BOX0102.00	LUNGHEZZA CAVO 10 METRI / LENGHT CABLE 10 METERS



**VALVOLA DI RITEGNO A PALLA**  
*BALL CHECK VALVE*

CODICE-CODE	MISURA-SIZE
0663.BOX0102.00	2"

**TABELLE RESISTENZE CHIMICHE**  
**RESISTANCE CHEMICAL TABLES**



# TABELLA RESISTENZA CHIMICA RESISTANCE CHEMICAL TABLE

<b>E</b> EXCELLENT <b>G</b> GOOD <b>P</b> POOR <b>N</b> NOT RECOMMENDED - =NO INFORMATION AVAILABLE B = BOILING C = HOT Ta= ROOM TEMPERATURE		CONCENTRATION	TEMPERATURE °C	AISI 304 18/8/2 CF8M 1.4401-1.4408	AISI 316 18/8/2 CF8M 1.4401-1.4408	CARBON STEEL A 105/A216WCB	CAST IRON	BRASS
Acetaldehyde			Ta	E	E	P	P	-
Acetilene		+20	E	E	E	E	N	-
Acetic Acid	10%	+20	E	E	N	N	G	-
Acetic Acid	10%	B	G	N	N	N	N	-
Acetic Acid	20-80%	+20	E	G	N	N	N	-
Acetic Acid	80%	B	G	G	N	N	N	-
Acetic Acid (vapours)	30%	C	P	P	N	N	N	-
Acetic Anhydride		B	G	G	P	P	P	-
Acetic Ester	concentrated	+20	E	E	G	G	-	-
Acetic Solvents		Ta	E	E	E	G	-	-
Acetone		B	E	E	G	G	E	-
Acido Cresilico		+20	E	E	G	G	G	-
Acido Idrofluorosilicico		Ta	P	P	N	N	G	-
Acrylonitrile		Ta	E	E	E	E	-	-
Alcool Diacetone		Ta	E	E	E	E	-	-
Alum	10%	B	G	G	N	N	G	-
Alum	saturated	B	P	G	N	N	-	-
Aluminium Chloride	25%	+20	N	P	N	N	N	-
Aluminium (Chloride)	25%	+20	N	P	N	N	-	-
Aluminium (Chloride)	25%	B	N	N	N	N	-	-
Aluminium (Fluoride)	5%	+20	N	P	N	N	-	-
Aluminium Sulfate		+20	G	G	N	N	-	-
Aluminium Sulfate		B	P	G	N	N	-	-
Aluminium Sulphate		Ta	G	E	P	P	P	-
Ammines		+20	E	E	E	E	-	-
Ammonia	concentrated	+20	E	E	G	G	E	-
Ammonia	acquarosa	Ta	E	E	E	E	N	-
Ammonia	gaseous	C	N	N	P	P	-	-
Ammonium Bicarbonate		Ta	G	G	P	P	-	-
Ammonium Carbonate		+20	G	G	G	G	-	-
Ammonium Carbonate		Ta	G	G	G	G	-	-
Ammonium Chloride	10%	+20	G	G	P	P	N	-
Ammonium Chloride	10%	+20	G	G	P	P	-	-
Ammonium Chloride	10%	B	P	G	N	N	-	-
Ammonium Disulphate		+20	E	E	P	P	-	-
Ammonium Hydroxide		C	E	E	G	G	-	-
Ammonium Hydroxide	concentrated	Ta	E	E	G	G	-	-
Ammonium Hydroxide		C	E	E	G	G	N	-
Ammonium Monophosphate		+20	E	E	N	N	-	-
Ammonium Monophosphate		+20	E	E	N	N	-	-
Ammonium Nitrate		+20	G	G	G	G	-	-
Ammonium Nitrate	saturated	B	G	G	P	P	-	-
Ammonium Nitrate		+20	G	G	G	G	N	-
Ammonium Persulphate	5%	+20	G	G	N	N	-	-
Ammonium Phosphate		Ta	G	G	N	N	-	-
Ammonium Sulphate	5%	+20	P	G	P	P	-	-
Ammonium Sulphate	10%	B	N	P	N	N	-	-
Ammonium Sulphate	saturated	B	N	P	N	N	-	-
Ammonium Sulphate		+20	P	G	P	P	N	-
Ammonium Trisulphate		+20	G	E	G	G	-	-
Amyl Acetate	concentrated	+20	G	G	G	G	-	-
Amyl Acetate		Ta	G	G	P	P	G	-
Amyl Alcohol	concentrated	+20	E	E	N	N	E	-
Aniline	3%	+20	E	E	G	G	P	-
Aniline	concentrated	+20	G	G	G	G	P	-
Aniline (dyes)		Ta	E	E	P	P	P	-
Animal Oil		Ta	E	E	E	E	-	-
Antimony Trichloride		+20	N	N	N	N	-	-
Antimony Trichloride		Ta	N	N	N	N	-	-
Apple Juice		Ta	G	G	N	N	N	-
Asphalt		Ta	E	E	G	G	E	-
Barium Cholide	saturated	+20	P	G	P	P	P	-
Barium Cholide	water sol.	C	N	P	N	N	P	-
Barium Carbonate		Ta	G	G	G	G	E	-
BariumChloride	5%	+20	G	G	P	P	N	-
Barium Hydroxide		Ta	G	G	P	P	G	-



# TABELLA RESISTENZA CHIMICA

## RESISTANCE CHEMICAL TABLE

E EXCELLENT G GOOD P POOR N NOT RECOMMENDED --NO INFORMATION AVAILABLE B = BOILING C = HOT Ta= ROOM TEMPERATURE	CONCENTRATION	TEMPERATURE °C						CONCENTRATION	TEMPERATURE °C						
			ALSI 304 18/8/2 CF8M 1.4401-1.4408	ALSI 316 18/8/2 CF8M 1.4401-1.4408	CARBON STEEL A 105/A216WCB	CAST IRON	BRASS			ALSI 304 18/8/2 CF8M 1.4401-1.4408	ALSI 316 18/8/2 CF8M 1.4401-1.4408	CARBON STEEL A 105/A216WCB	CAST IRON	BRASS	
Copper Nitrate	5%	+20	E	E	N	N	P	Hydrofluoric Acid	concentrated	+20	N	N	N	N	N
Copper Nitrate	5%	220	E	E	N	N	--	Hydrofluoric Acid	dry	+20	P	P	P	P	N
Copper Nitrate	50%	C	G	G	N	N	--	Hydrofluoric Acid	wet	+20	N	N	N	N	N
Copper Sulphate	saturated	+20	G	G	N	N	--	Hydrofluoric Acid	cold	+20	N	N	N	N	N
Copper Sulphate		B	G	G	N	N	N	Hydrogen Gas		Ta	E	E	G	G	--
Copper Sulphate	+20	G	G	N	N	N	--	Hydrogen Dioxide	+20	E	E	N	N	N	
Creosote	C	G	G	G	G	--	Hydrogen Dioxide	B	G	G	N	N	N		
Creosote Oil	Ta	G	G	G	G	E	illuminating Gas	Ta	E	E	E	E	--		
Cyclohexane	Ta	E	E	E	E	--	Ink	Ta	E	E	N	N	--		
Dichloroethane	B	G	G	N	N	--	Iodine	dry	+20	N	N	P	N	--	
Diethylamine	Ta	E	E	E	E	--	Iodine	wet	+20	N	N	N	N	--	
Diethyl Ether	+20	E	E	E	G	--	Iodoform	+20	E	E	N	N	--		
Distilled Water	Ta	E	E	P	P	E	Isocetane	Ta	E	E	E	E	--		
Epsom Salt	Ta	G	G	P	P	--	Isopropyl Ether	Ta	E	E	E	G	--		
Ethane	Ta	G	G	G	G	E	Isopropyl Alcohol	Ta	G	G	G	G	--		
Ethyl Acrylate	Ta	E	E	P	P	--	Juices	B	G	E	N	N	N		
Ethyl Alcohol	B	G	G	G	G	E	Ketone	Ta	E	E	E	E	--		
Ethyl Acetate	Ta	G	G	G	G	E	Kerosene	Ta	E	E	G	G	--		
Ethyl Chloride	dry	+20	E	E	E	E	Lactic Acid	1%	B	G	G	N	N	P	
Ethyl Chloride	+20	E	E	E	E	G	Lactic Acid	5%	+70	G	G	N	N	P	
Ethylene Glycol	+20	E	E	E	E	G	Lactic Acid	5%	B	N	G	N	N	P	
Ethylene Oxide	Ta	G	G	G	G	E	Lactic Acid	5-10%	+20	G	E	N	N	P	
Fatty Acids	B	G	G	P	P	N	Lactic Acid	10%	+70	P	G	N	N	P	
Ferric Chloride	1%	+20	N	P	N	N	Lactic Acid	10%	B	N	P	N	N	P	
Ferric Chloride	5%	+20	N	N	N	N	Lactic Acid	concentrated	B	N	N	N	N	P	
Ferric Nitrate	Ta	P	P	N	N	N	Latex	+20	E	E	N	N	--		
Ferric Nitrate	5%	+20	G	G	N	N	Latex Emulsions	Ta	E	E	G	G	--		
Ferric Sulphate	+20	G	E	N	N	N	Lead Acetate	+20	G	G	N	N	--		
Ferric Sulphate	5%	B	G	G	N	N	Lead Acetate	Ta	G	G	N	N	--		
Ferrous Chloride	Ta	N	N	N	N	N	Lemon Juice	Ta	G	G	N	N	N		
Ferrous Sulphate	saturated	+20	G	G	N	N	Linoleic Acid	Ta	E	E	G	G	--		
Ferrous Sulphate	10%	+20	G	G	N	N	Linseed Oil	Ta	G	G	E	E	G		
Fertilizers	Ta	G	G	G	G	--	Liquefied Gas (LPG)	Ta	G	G	G	G	--		
Fish Oil	dry	+20	E	E	G	G	Lithium	+150	E	E	G	G	--		
Fluorine	dry	+20	G	G	N	N	Lubricating Oil	Ta	E	E	E	E	--		
Formaldehyde	Cold	E	E	E	G	P	Lye	B	G	G	N	N	N		
Formaldehyde	Hot	P	P	N	N	P	Lysol	+20	P	P	N	N	--		
Formic Acid	5-50%	+20	G	G	N	N	Magnesium Chloride	5%	+20	G	G	N	N	N	
Formic Acid	10-50%	B	N	N	N	N	Magnesium Chloride	5%	C	N	N	N	N		
Formic Acid	100%	+20	P	P	N	N	Magnesium Chloride	10-30%	+20	P	G	N	N	N	
Formic Acid	100%	B	N	N	N	N	Magnesium Chloride	saturated	+20	P	G	N	N	N	
Freon	dry	Ta	E	E	E	E	Magnesium Chloride	5%	+20	G	G	N	N	N	
Freon	wet	Ta	P	P	P	P	Magnesium Disulphate	Ta	E	E	G	G	--		
Fuel Oil	Ta	E	E	G	G	E	Magnesium Hydroxide	C	E	E	G	G	G		
Furfuraldehyde	+20	G	G	G	G	E	Magnesium Oxide	+20	G	G	G	G	--		
Galic Acid	5%	+70	G	G	N	N	Magnesium Sulphate	+20	G	G	G	G	P		
Gas Chlorate	dry	+20	N	P	G	G	Magnesium Sulphate	+20	G	G	G	G	P		
Gas Chlorate	wet	+100	N	N	N	N	Maleic Acid	Ta	G	G	G	G	--		
Gaseous Methyl Chloride	+20	G	G	N	N	--	Malic Acid	C	G	G	N	N	--		
Gelatine	Ta	E	E	N	N	G	Mercury	+150	P	P	G	G	N		
Glue	Ta	G	G	E	E	--	Mercury	+500	N	N	N	N	N		
Glucose	Ta	G	G	G	G	E	Mercury Bichloride	+20	N	N	N	N	N		
Glycerol	+20	E	E	E	E	E	Mercury Cyanide	+20	G	G	N	N	N		
Glycols	Ta	G	G	G	G	--	Mercury Cyanide	+20	G	G	N	N	--		
Heptane	Ta	E	E	E	G	--	Mercuric Chloride	Ta	N	P	N	N	--		
Hexane	Ta	G	G	G	G	--	Methane	Ta	G	G	G	G	E		
Hexanol	Ta	E	E	E	E	--	Methyl Acetate	Ta	E	E	G	G	--		
Hydraulic Oil	Ta	E	E	E	E	--	Methyl Alcohol	B	P	G	G	G	E		
Hydriodic Acid (iodidrico)	diluted	+20	N	N	N	N	Methylacetone	Ta	E	E	G	G	--		
Hydrocarbons	+20	E	E	E	E	E	Methylamine	Ta	E	E	G	G	--		
Hydrobromic Acid	+20	N	N	N	N	N	Methyl Chloride	+20	G	G	N	N	G		
Hydrocyanic Acid	+20	G	G	P	P	--	Methylene Chloride	Ta	E	E	G	G	G		
Hydrochloric Acid	1%	+20	N	P	N	N	Methyl Formate	Ta	G	G	P	P	--		
Hydrochloric Acid	1%	B	N	N	N	N	Milk	+20	E	E	N	N	G		
Hydrochloric Acid	5%	+20	N	N	N	N	Mineral Naphtha	+20	G	G	G	G	G		
Hydrochloric Acid	+20	N	N	N	N	N	Mineral Oil	Ta	E	E	G	G	E		



# TABELLA RESISTENZA CHIMICA RESISTANCE CHEMICAL TABLE

<b>E</b> EXCELLENT <b>G</b> GOOD <b>P</b> POOR <b>N</b> NOT RECOMMENDED - =NO INFORMATION AVAILABLE B = BOILING C = HOT Ta= ROOM TEMPERATURE		CONCENTRATION	TEMPERATURE °C	AISI 304 18/8/2 CF8M 1.4401-1.4408	AISI 316 18/8/2 CF8M 1.4401-1.4408	CARBON STEEL A 10S/A216WCB	CAST IRON	BRASS
Mineral Water			Ta	G	G	P	P	G
Mixed Acid-turpentine		+20	N	N	N	N	N	N
Muriatic Acid		+20	N	P	N	N	N	N
Naphthalene		Ta	G	G	E	E	—	—
Natural Gas		Ta	E	E	G	G	E	E
Neon		+20	G	G	G	G	—	—
Nickel Chloride		+20	P	G	N	N	P	P
Nichel Chloride		+20	P	G	N	N	P	P
Nichel Sulphate		C	P	G	N	N	P	P
Nickel Sulphate		C	P	G	N	N	P	P
Nickel Nitrate		Ta	G	G	N	N	—	—
Nicotinic Acid		Ta	E	E	G	G	—	—
Nitric Acid	5-50%	+20	E	E	N	N	N	N
Nitric Acid	10-50%	B	G	P	N	N	N	N
Nitric Acid	85%	+20	G	G	G	G	N	N
Nitric Acid	85%	C	G	P	N	N	N	N
Nitric Acid	concentrated	+20	G	G	G	G	N	N
Nitric Acid	concentrated	B	P	P	N	N	N	N
Nitric Acid	anhydrous	Ta	E	E	E	E	N	N
Nitrobenzene		Ta	G	G	G	G	—	—
Nitrogen		Ta	E	E	E	E	E	E
Nitrous Acid	5%	+20	G	G	N	N	—	—
Nitrous Gases		Ta	E	E	G	G	—	—
Nitrous Oxide		Ta	G	G	G	G	—	—
Oil		Ta	E	E	G	G	G	G
Oleic Acid	crude	+20	G	G	P	P	—	—
Oleum		Ta	G	G	G	G	—	—
Olive Oil		Ta	E	E	G	G	P	P
Oxalic Acid	5%	C	P	P	N	N	—	—
Oxalic Acid	10%	+20	G	G	P	P	—	—
Oxalic Acid		B	N	N	N	N	—	—
Oxalic Acid	saturated	+20	G	G	P	P	—	—
Oxalic Acid	saturated	B	N	N	N	N	—	—
Oxygen	cold		E	E	G	G	E	E
Oxygen		+250	G	G	G	G	—	—
Ozone	dry	Ta	E	E	P	P	—	—
Ozone	wet	Ta	E	E	E	E	—	—
Paint Varnish		Ta	E	E	P	P	—	—
Palm Oil		Ta	G	G	P	P	—	—
Palmitic Acid		+20	G	G	P	P	P	P
Paraformaldehyde		Ta	G	G	G	G	—	—
Paraffin Wax		Ta	E	E	E	E	E	E
Pentane		Ta	E	E	G	G	—	—
Perchloroethylene		Ta	E	E	G	G	P	P
Peroxide		Ta	G	G	N	N	N	N
Petrol		Ta	E	E	E	E	E	E
Petrol (Crude)		+20	E	E	P	P	E	E
Phenol		B	G	G	P	P	—	—
Phosphoric Acid	C.P. 1%	+20	G	G	N	N	N	N
Phosphoric Acid	5%	+20	G	G	N	N	N	N
Phosphoric Acid	10%	+20	P	G	N	N	N	N
Phosphoric Acid	20-45%	B	N	P	N	N	N	N
Phosphoric Acid	45-85%	+20	N	G	N	N	N	N
Phosphoric Acid	85%	B	N	N	N	N	N	N
Phthalic Acid		Ta	G	G	P	P	—	—
Phthalic Anhydride			E	E	P	P	—	—
Picric Acid	water sol.	+20	E	E	P	P	N	N
Potassium Bichromate		+20	G	G	P	P	—	—
Potassium Bisulphite		Ta	G	G	N	N	—	—
Potassium Bromide		+20	P	G	N	N	—	—
Potassium Bromide		+20	P	G	N	N	—	—
Potassium Carbonate	1%	+20	E	G	G	G	P	P
Potassium Carbonate	1%	+20	G	G	G	G	—	—
Potassium Chlorate		+20	G	G	G	G	—	—
Potassium Chloride	1-5%	+20	P	G	N	N	P	P
Potassium Chlorate		+20	G	G	G	G	N	N



# TABELLA RESISTENZA CHIMICA RESISTANCE CHEMICAL TABLE

E EXCELLENT G GOOD P POOR N NOT RECOMMENDED - =NO INFORMATION AVAILABLE B = BOILING C = HOT Ta= ROOM TEMPERATURE	CONCENTRATION	TEMPERATURE °C	AISI 304 18/8/2 CF8M 1.4401-1.4408		AISI 316 18/8/2 CF8M 1.4401-1.4408		CARBON STEEL A 105/A216WCB	CAST IRON	BRASS	E EXCELLENT G GOOD P POOR N NOT RECOMMENDED - =NO INFORMATION AVAILABLE B = BOILING C = HOT Ta= ROOM TEMPERATURE	CONCENTRATION	TEMPERATURE °C	AISI 304 18/8/2 CF8M 1.4401-1.4408		AISI 316 18/8/2 CF8M 1.4401-1.4408		CARBON STEEL A 105/A216WCB	CAST IRON	BRASS
Sodium Metaphosphate	cold	Ta	E	E	G	G	N			Varnish		+20	E	E	P	P	E		
Sodium Metasilicate		C	E	E	P	P	-			Varnish		C	G	G	N	N	E		
Sodium Metasilicate			E	E	N	N	-			Vaseline		Ta	G	G	P	P	-		
Sodium Nitrate			+20	E	E	G	G	-		Vinegar (vapors)		Ta	G	G	N	N	-		
Sodium Nitrate			Ta	G	G	G	G	P		Viscose		Ta	G	G	G	G	-		
Sodium Perborate			Ta	G	G	G	G	-		Waste Water		+20	G	G	P	P	-		
Sodium Peroxide			Ta	G	G	P	P	P		Wax		Ta	E	E	E	E	-		
Sodium Phosphate			Ta	G	G	P	P	-		Wax Emulsions		Ta	E	E	E	E	-		
Sodium Silicate			Ta	G	G	G	G	G		Xylene		Ta	E	E	G	G	-		
Sodium Silicate			C	G	G	P	P	G		Zinc Chloride		dry							
Sodium Silicate		Ta	G	G	G	G	-		5%		5%	+20	P	G	N	N	-		
Sodium Sulphate	saturated	+20	P	G	G	G	G			5%		B	N	P	N	N	-		
Sodium Sulphate			+20	P	G	G	G	G		5%		+20	P	G	N	P	N	-	
Sodium Sulphite	10%	+65	P	G	G	G	G			Zinc Chloride		Ta	E	E	E	E	-		
Sodium Sulphite	10%	B	P	G	N	N	G			Zinc Chloride		+20	G	E	G	G	G		
Sodium Sulphite	saturated	+20	G	G	G	G	G			Zinc Hydrosulphite		Ta	E	E	E	E	-		
Sodium Trisulphate	20%	+20	G	G	N	N	-			Zinc Sulphate		+20	G	E	G	G	G		
Sodium Thiosulphate		Ta	E	E	G	G	-			Zinc Sulphate		B	P	G	N	N	G		
Soft Water		Ta	E	E	P	P	N			Zinc Sulphate		Ta	G	G	N	N	N		
Solvent		Ta	E	E	G	G	E												
Spirit Vinegar		+20	E	E	N	N	-												
Starci		Ta	G	G	P	P	-												
Stannic Chloride	5%	+20	N	P	N	N	-												
Stannic Chloride	5%	B	N	N	N	N	-												
Stannic Chloride	5%	+20	N	P	N	N	-												
Stannous Chloride	saturated	+20	N	P	N	N	-												
Stearic Acid		+20	G	E	P	P	P												
Strontium Nitrate		+20	E	E	N	N	-												
Styrene		Ta	E	E	E	E	-												
Suds (Stearate)		Ta	E	E	E	G	-												
Sugary Juices in general		+70	G	G	N	N	N												
S Sulphur	dry and liquefied	+230	G	G	G	G	N												
S Sulphur	wet and liquefied	+230	P	G	N	N	N												
Sulphuric Anhydride	dry	Ta	E	E	G	G	G												
Sulphuric Acid	dry	+20	E	E	E	E	-												
Sulphuric Acid	wet	+20	P	G	P	P	-												
Sulphuric Acid	5%	+20	P	G	N	N	N												
Sulphuric Acid	5%	B	N	P	N	N	N												
Sulphuric Acid	10%	+20	N	P	N	N	N												
Sulphuric Acid	10%	B	N	N	N	N	N												
Sulphuric Acid	50%	+20	N	N	N	N	N												
Sulphuric Acid	50%	B	N	N	N	N	N												
Sulphuric Acid	concentrated	+20	G	G	G	G	N												
Sulphuric Acid	concentrated	B	N	N	N	N	N												
Sulphuric Acid	fuming	+20	P	G	P	P	N												
Sulphur Chloride		Ta	P	G	N	N	-												
Sulphur Dioxide	dry	+250	G	G	G	G	E												
Sulphur Dioxide	dry	+230	G	G	G	G	N												
Sulphur Dioxide	wet	+20	P	G	N	N	N												
Sulphurous Acid	saturated	+20	N	G	N	N	P												
Syngas		Ta	G	G	G	G	-												
Tannic Acid		+20	G	G	N	N	G												
Tar		Ta	E	E	E	E	G												
Tartaric Acid	10%	+20	E	E	N	N	P												
Tartaric ACid	10%	C	P	G	N	N	P												
Tetraethyl Lead		Ta	G	G	P	P	-												
Titanium Tetrachloride	wet	+20	N	N	N	N	-												
Tomato Juice		Ta	E	E	P	P	N												
Toluene		Ta	E	E	E	E	E												
Tributyl Phosphate		Ta	E	E	E	E	-												
Trichloroethylene	dry	Ta	G	G	G	P	E												
Trichloroacetic Acid		+20	N	N	N	N	P												
Tung Oil		Ta	G	G	P	P	-												
Turpentine		+20	E	E	E	E	G												
Urea		Ta	G	G	P	P	-												
Uric Acid	concentrated	+20	G	G	N	N	-												



# TABELLA RESISTENZA CHIMICA

## RESISTANCE CHEMICAL TABLE

E EXCELLENT G GOOD P POOR N NOT RECOMMENDED --NO INFORMATION AVAILABLE	DELNRIN	EPDM	NBR	VITON	PTFE	E EXCELLENT G GOOD P POOR N NOT RECOMMENDED --NO INFORMATION AVAILABLE	DELNRIN	EPDM	NBR	VITON	PTFE
Acetaldehyde	G	--	N	N	E	Barium Carbonate	--	E	--	--	E
Acetal	--	--	--	--	E	Barium Chloride	E	E	G	G	E
Acetamide	--	E	G	G	E	Barium Hydroxide	--	E	G	G	E
Acetate Solvent	--	--	N	N	E	Barium Nitrate	--	E	G	G	E
Acetilene	E	E	G	G	E	Barium Sulphate	--	E	G	G	E
Acetic Acid 10-20%	N	E	E	E	E	Barium Sulphide	--	--	G	G	E
Acetic Acid 50%	N	--	E	E	E	Beer	--	--	G	G	E
Acetic Acid 80%	N	E	G	G	E	Benzaldehyde	--	--	N	N	E
Acetic Anhydride	N	--	N	N	E	Benzene, Benzol	--	--	N	N	E
Acetylene Chloride	--	--	N	E	E	Benzoic Acid	--	E	N	G	E
Acetoacetato di Etile	--	--	N	N	E	Benzykl Alcohol	--	--	N	E	E
Acetofenone	--	--	N	N	E	Benzyl Chloride	--	--	N	--	E
Acetone	E	E	N	N	E	Black Liquor	--	--	E	G	E
Acetone 50% water	--	--	N	--	E	Borax	E	E	G	G	E
Acetonitrile	--	--	--	--	E	Boric Acid	E	E	G	G	E
Acid Chloric 20%	--	--	N	N	E	Brine	--	G	E	--	E
Acid Laisileico	--	--	G	G	E	Bromine Water	--	--	N	E	E
Acido Cresilico	N	--	N	E	E	Butyl Acetate	--	--	--	--	E
Acrylonitrile	--	--	N	N	E	Butyl Alcohol	E	E	N	E	E
Adipic Acid	--	--	N	--	E	Butyric Acid	E	N	N	--	E
Air	--	E	E	E	E	Butyl Chloride	--	--	--	--	E
Alumed Chrome	--	E	G	G	E	Butyl Phenol	--	--	--	--	E
Alumed Potassium	--	E	G	G	E	Butyl Phthalate	--	--	N	--	E
Alumed Potassium Sulphate	--	E	--	--	E	Butter	--	--	E	--	E
Alumina	--	E	E	G	E	Butadiene	E	--	E	E	E
Aluminium Chloride	E	E	G	G	E	Butane	E	E	N	E	E
Aluminium Fluoride	--	E	G	G	E	Butylene	E	--	N	G	E
Aluminium Hydroxide	E	E	G	G	E	Calcium Bisulphite	E	E	G	G	E
Aluminium Nitrate	--	E	G	G	E	Calcium Bicarbonate	--	--	--	--	E
Aluminium Sulphate	E	E	G	G	E	Calcium Carbonate	E	E	G	G	E
Alum. (All. Potassium Sulphate)	E	E	E	--	E	Calcium Chlorate	--	--	G	G	E
Amyl Alcohol	E	E	--	--	E	Calcium Chloride	E	E	G	G	E
Amyl Acetate	E	N	N	N	E	Calcium Disulphate	--	--	--	--	E
Ammonium Acetate	--	E	N	--	E	Calcium Fluoride	--	--	--	--	E
Ammonia (Anhydrous)	--	E	G	N	E	Calcium Hydroxide	E	E	G	G	E
Ammonia (Gas)	--	--	G	N	E	Calcium Htpochlorite	E	E	N	G	E
Ammonium Chloride	P	E	G	G	E	Calcium Nitrate	--	E	G	G	E
Ammonium Sulphate	E	E	G	N	E	Calcium Oxide 20°C	--	--	--	--	E
Ammonium Sulphite 50°C	--	--	E	--	E	Calcium Sulphate	E	E	--	--	E
Ammonium Sulphide	--	E	G	N	E	Cane Sugar Liquor	--	E	G	G	E
Ammonium Hydroxide	--	E	G	G	E	Carbolic Acid (phenol)	N	E	G	G	E
Ammonium Fluoride 25%	--	E	--	--	E	Carbonic Acid	--	--	N	G	E
Ammonium Phosphate	--	E	G	G	E	Carbon Bisulphide	--	--	N	G	E
Ammonium Metaphosphate	--	--	G	G	E	Carbon Dioxide	--	--	E	--	E
Ammonium Nitrate	E	E	G	N	E	Carbon Monoxide	--	E	G	G	E
Ammonium Oxalate	--	E	--	--	E	Castor Oil	E	E	G	G	E
Ammonium Bicarbonate	P	E	--	--	E	Caustic Soda	--	E	P	--	E
Ammonium Bifluoride	--	E	--	--	E	Cellulose Acetate	--	E	N	N	E
Ammonium Carbonate	P	E	G	G	E	Cellosolve	--	E	N	N	E
Amyl Chloride 77°C	--	--	N	E	--	Cement	--	E	G	--	E
Anhydrous Formic Acid	N	--	N	G	E	Cereal Syrup (Glucose)	--	--	G	G	E
Aniline	E	N	N	E	E	Chloroacetic Acid	--	--	N	N	E
Aqua Regia	--	--	N	E	E	Chloroform	E	N	N	G	E
Arsenic Acid	--	E	G	G	E	Chlorosulfonic Acid	--	--	--	--	E
Artificial Gas	--	--	G	--	E	Chlorine Dioxide	--	--	N	--	--
Asphalt	E	--	N	E	E	Chlorine Water	--	--	N	E	E



# TABELLA RESISTENZA CHIMICA RESISTANCE CHEMICAL TABLE

<div style="display: flex; flex-direction: column; gap: 2px;"> <div style="display: flex; align-items: center;"><span style="background-color: #90EE90; border: 1px solid black; padding: 2px;">E</span> EXCELLENT</div> <div style="display: flex; align-items: center;"><span style="background-color: #ADD8E6; border: 1px solid black; padding: 2px;">G</span> GOOD</div> <div style="display: flex; align-items: center;"><span style="background-color: #FFD700; border: 1px solid black; padding: 2px;">P</span> POOR</div> <div style="display: flex; align-items: center;"><span style="background-color: #FF4500; border: 1px solid black; padding: 2px;">N</span> NOT RECOMMENDED</div> </div> <div style="display: flex; align-items: center;"><span style="color: gray;">--</span> NO INFORMATION AVAILABLE</div>	DELTRIN	EPDM	NBR	VITON	PTFE		<div style="display: flex; flex-direction: column; gap: 2px;"> <div style="display: flex; align-items: center;"><span style="background-color: #90EE90; border: 1px solid black; padding: 2px;">E</span> EXCELLENT</div> <div style="display: flex; align-items: center;"><span style="background-color: #ADD8E6; border: 1px solid black; padding: 2px;">G</span> GOOD</div> <div style="display: flex; align-items: center;"><span style="background-color: #FFD700; border: 1px solid black; padding: 2px;">P</span> POOR</div> <div style="display: flex; align-items: center;"><span style="background-color: #FF4500; border: 1px solid black; padding: 2px;">N</span> NOT RECOMMENDED</div> </div> <div style="display: flex; align-items: center;"><span style="color: gray;">--</span> NO INFORMATION AVAILABLE</div>	DELTRIN	EPDM	NBR	VITON	PTFE
Chlorine Water	--	--	N	--	E	Ethyl Glycol	--	E	E	E	E	
Chlorobenzene	E	N	N	G	E	Ethylene Bromide	--	--	N	--	E	
Chromic Acid	N	--	G	E	E	Ethylene Chloride	--	--	N	E	E	
Chromic Anhydride	--	--	G	E	E	Ethylene Diamine	--	--	E	E	E	
Chrome Potassium Sulphate	--	--	G	--	E	Ethylene Glycol	--	E	G	E	E	
Citric Acid	--	E	G	G	E	Ethylene Oxide	--	--	N	N	E	
Coconut Oil	E	--	G	E	E	Epichlorohydrin	--	--	N	N	E	
Coffee	--	E	N	E	E	Fats	--	N	E	--	E	
Coke-oven Gas	--	E	N	G	E	Fatty Acids	--	--	G	G	E	
Copper Acetate	--	--	--	N	E	Ferric Chloride	E	E	G	G	E	
Copper Chloride	E	E	G	G	E	Ferric Nitrate 10-50%	--	E	G	G	E	
Copper Nitrate	E	--	G	G	E	Ferric Sulphate	E	E	G	G	E	
Copper Sulphate	E	E	G	G	E	Feerous Chloride	E	E	G	--	E	
Corn Oil	E	--	N	--	E	Ferrous Sulphate	E	E	G	G	E	
Cotton seeds Oil	--	--	G	E	E	Fluorinated Hydrogen	--	--	G	G	E	
Creosote	--	N	P	E	E	Fluorine Gas	--	--	N	N	E	
Cresol	--	--	N	N	E	Fluorosilicic Acid	--	E	P	--	--	
Cromil Chloride	--	--	--	--	E	Formaldehyde 35-50%	E	E	N	N	E	
Crotonaldehyde	--	--	--	--	E	Formic Acid 10-85%	N	E	N	G	E	
Crude Oil	--	--	G	E	E	Freon F 11-12	--	--	G	G	--	
Cyanoacetic Acid	--	--	--	--	E	Freon F 22	--	--	N	N	--	
Cyanogen Gas	--	E	--	--	E	Fuel Oil	E	N	G	E	E	
Cyclohexane	--	N	G	G	E	Fuel for aircrafts (JP4 or JP5)	--	N	G	E	E	
Demineralized Water	--	E	G	G	E	Furfural	--	--	N	N	E	
Detergents	--	E	G	G	E	Furfuraldehyde	E	--	N	N	E	
Dextrite	--	--	N	N	E	Gallic Acid	E	E	--	G	E	
Dextrose	--	--	G	G	E	Galvanizing Solution	--	E	G	G	E	
Diacetone	--	E	N	N	E	Gaseous Bromine	G	N	N	--	E	
Diacetone Alcohol	--	--	N	--	E	Gaseous Oxygen	E	--	N	G	E	
Dibutylphthalate	--	--	--	G	E	Gas Oil	--	--	G	G	E	
Dichloroethane	--	--	N	E	E	Gelatine	E	--	G	G	E	
Dichlorobenzene max 40°C	--	--	--	G	E	Glucose	E	--	G	G	E	
Dichloroethane	--	--	N	G	E	Glue	--	E	P	--	E	
Dichloroethylene	--	--	N	G	E	Glycerol	P	--	G	E	E	
Diethyl Ether	--	--	N	N	E	Glycols 60°C	--	--	E	E	E	
Diethyl Ether 40°C	--	--	G	N	E	Glycocic Acid	--	E	--	--	E	
Diethylcellosolve	--	--	--	--	E	Green Liquor	--	E	G	--	E	
Diethylamine max 40°C	--	--	N	--	E	Helium	--	G	G	--	E	
Dimethyl	--	--	--	N	E	Heptane	--	E	G	E	E	
Dimethylphthalate	--	--	N	E	E	Hexane	--	N	G	E	E	
Dimethyl Ether	--	--	--	--	E	Hexanol	--	--	G	E	E	
Dioxan	--	N	N	N	E	Hydraulic Fluid	--	--	G	E	E	
Diphenil (Dowtherms)	--	--	N	E	E	Hydrobromic Acid	--	--	N	G	E	
Disodium Phosphate 20°C	--	--	N	G	E	Hydrocyanic Acid	--	E	G	G	E	
Distiller Water	E	E	G	G	E	Hydrochloric Acid max 50%	--	E	--	G	E	
Dry Sulphur Dioxide	N	--	N	N	E	Hydrofluoric Acid max 70%	--	--	N	E	--	
Drilling Sludge	--	N	E	--	E	Hydrofluoric Acid 100%	--	--	N	--	--	
Drilling Sludge	--	N	E	--	E	Hydrogen Dioxide	E	E	N	E	E	
Dry Sulphurized Hydrogen	--	E	--	N	E	Hydrogen Chloride	--	--	--	--	E	
Dry Sulphurized Hydrogen	--	E	--	N	E	Hydrogen	--	E	G	G	--	
Dyes	--	N	N	--	E	Hydrogen Sulphide	--	--	N	N	E	
Dyes	--	N	N	--	E	Hydroquinone	--	E	N	G	E	
Ethyl Acetate	E	N	N	N	E	Ink	--	E	--	--	--	
Ethyl Acrylate	--	E	G	G	E	Industrial Oils	--	--	--	--	E	
Ethyl Alcohol	E	E	P	E	E	Iodoform	E	--	N	E	E	
Ethyl Chloride	E	--	G	G	E	Isobutyl-Methyl-Ketone	--	--	N	N	E	



# TABELLA RESISTENZA CHIMICA

## RESISTANCE CHEMICAL TABLE

	DELTRIN	EPDM	NBR	VITON	PTFE		DELTRIN	EPDM	NBR	VITON	PTFE
<b>E</b> EXCELLENT						<b>E</b> EXCELLENT					
<b>G</b> GOOD						<b>G</b> GOOD					
<b>P</b> POOR						<b>P</b> POOR					
<b>N</b> NOT RECOMMENDED						<b>N</b> NOT RECOMMENDED					
--NO INFORMATION AVAILABLE						--NO INFORMATION AVAILABLE					
Isooctane	E	N	E	P	E	Nickel Nitrate	E	--	G	G	E
Isopropyl Alcohol	E	E	P	G	E	Nickel Salt	--	--	G	--	E
Isopropyl Ether	--	--	N	N	E	Nickel Sulphate	E	E	G	G	E
Juices	E	G	G	--	E	Nicotine	--	--	--	--	E
Kerosene	--	--	G	E	E	Nicotinic Acid	--	E	--	--	E
Lactic Acid	N	--	N	G	E	Nitric Acid	N	N	N	G	E
Lard Oil	--	--	E	E	E	Nitrobenzene 25°C	--	G	N	N	E
Lead Acetate	E	--	N	N	E	Nitrobenzene over 25°C	--	--	N	N	E
Lead Chloride max 20°C	--	--	--	G	E	Nitrogen	E	E	G	--	E
Lead Sulphate	--	--	P	--	E	Nitromethane	--	--	N	--	E
Leaded Petrol	E	--	G	G	E	Nitrous Oxide 40°C	--	--	N	P	E
Lemon Oil	--	G	P	--	E	Oleum	N	--	N	E	E
Lime	--	E	N	--	E	Oleic Acid	E	--	E	N	E
Lime Sulphur	--	E	N	G	E	Oli Vegetali	--	E	G	G	E
Linseed Oil	E	--	G	E	E	Olive Oil	--	G	E	E	E
Liquid Chlorine	--	--	N	G	E	Oxalic Acid	P	E	E	G	E
Liquid Soap	--	E	G	--	E	Oxygen	E	E	P	G	E
Lithium Bromine	--	E	G	G	E	Ozone	--	--	N	G	E
Lubricating Oil	--	--	G	G	E	Paint Solvents	--	N	N	N	E
Maleic Acid	E	E	N	G	E	Palmitic Acid	E	--	G	G	E
Malic Acid	E	--	G	G	E	Paraffin Wax	E	--	G	--	E
Manganese Chloride max 20°C	--	--	G	G	E	Perchloric Acid	--	--	N	G	E
Magnesium Carbonate	--	--	G	--	E	Perchloroethylene	--	N	N	E	E
Magnesium Chloride	E	E	G	G	E	Persolfato di Ammonio	--	E	G	--	E
Magnesium Hydroxide	E	E	G	G	E	Petrol Oils (acid or refined oils)	--	--	G	G	E
Magnesium Nitrate	--	E	G	--	E	Petrolutum (Vaseline)	--	--	--	--	E
Magnesium Oxide	--	G	G	--	E	Phenil Chloride (Chlorobenzene)	--	--	N	E	E
Machine Oil	--	--	--	--	E	Phenylhydrazine	--	--	N	G	E
Magnesium Sulphate	E	E	G	--	E	Phenol (Carbolic Acid)	N	--	N	E	--
Methane	E	E	G	E	E	Phosphate 50°C	--	--	--	--	E
Methanol	--	E	G	N	E	Phosphoric Acid 10%	N	--	N	G	E
Methyl Acetate	--	P	N	N	E	Phosphoric Acid 25/50%	N	--	N	G	E
Methyl Alcohol	E	E	G	N	E	Phosphoric Acid 50/80%	N	E	N	G	E
Methyl Bromine	--	--	--	G	E	Phosphorous Oxichloride	--	--	--	--	E
Methyl Chloride	--	--	N	G	E	Phosphorous Pentoxide 20°C	--	--	--	--	E
Methyl Methacrylate	--	--	G	G	E	Phosphorous Pentoxide	--	--	N	N	E
Methylene Chloride	--	N	N	N	E	Phthalic Acid	E	--	N	--	E
Methylacetone	--	G	N	N	E	Phthalic Anhydride	--	--	N	G	E
Methylcellosolve	--	--	P	N	E	Picric Acid	--	E	P	G	E
Methyl-Ethyl-Ketone	--	--	N	N	E	Pickling solution	--	N	--	--	E
Mercury	E	--	G	G	E	Polyvinyl Acetate	--	E	--	--	E
Mercuric Chloride	--	E	G	G	E	Potassium Bicarbonate	--	--	G	G	E
Mercuric Nitrate	--	E	--	--	E	Potassium Bichromate (30%)	--	--	N	N	E
Milk	E	--	G	G	E	Potassium Bromide	E	E	G	G	E
Mineral Oil	E	--	G	G	E	Potassium Carbonate 50%	E	--	G	G	E
Mineral Water	E	E	G	--	E	Potassium Chlorate	--	E	G	G	E
Mineral Naphtha (Combustible Oil)	E	N	G	E	E	Potassium Chloride	E	E	G	G	E
Mixed Acids (*T max 32°C)	--	E	E	E	E	Potassium Chromate 30%	--	E	--	--	E
Molasses Monochlorobenzene 20°C	--	E	G	G	E	Potassium Cyanide 30%	E	E	G	G	E
Motor Oil	--	--	N	E	E	Potassium Ferricyanide 30%	--	--	G	G	E
n Butyl Mercaptan	--	--	--	--	E	potassium Fluoride	--	--	G	G	E
Naphthalene	E	--	N	G	E	Potassium Hydroxide	--	--	G	G	E
Natural Gas	E	E	G	G	E	Potassium Hydroxide 5-30%	--	E	N	--	E
Nickel Ammonium Sulphate	--	--	--	--	E	potassium Hydroxide 50-90%	--	E	G	N	E
Nickel Chloride	E	E	G	--	E	PotassiumHypochlorite 30°C	--	--	N	G	E
						Potassium Hypochlorite 90°C	--	--	N	--	E



# TABELLA RESISTENZA CHIMICA

## RESISTANCE CHEMICAL TABLE

<table border="1" style="font-size: 8px;"> <tr><td style="background-color: #e8f5e9;">E</td><td>EXCELLENT</td></tr> <tr><td style="background-color: #e8f5e9;">G</td><td>GOOD</td></tr> <tr><td style="background-color: #fff9c4;">P</td><td>POOR</td></tr> <tr><td style="background-color: #ffe0b2;">N</td><td>NOT RECOMMENDED</td></tr> <tr><td colspan="2">--NO INFORMATION AVAILABLE</td></tr> </table>	E	EXCELLENT	G	GOOD	P	POOR	N	NOT RECOMMENDED	--NO INFORMATION AVAILABLE		DELTRIN	EPDM	NBR	VITON	PTFE	<table border="1" style="font-size: 8px;"> <tr><td style="background-color: #e8f5e9;">E</td><td>EXCELLENT</td></tr> <tr><td style="background-color: #e8f5e9;">G</td><td>GOOD</td></tr> <tr><td style="background-color: #fff9c4;">P</td><td>POOR</td></tr> <tr><td style="background-color: #ffe0b2;">N</td><td>NOT RECOMMENDED</td></tr> <tr><td colspan="2">--NO INFORMATION AVAILABLE</td></tr> </table>	E	EXCELLENT	G	GOOD	P	POOR	N	NOT RECOMMENDED	--NO INFORMATION AVAILABLE		DELTRIN	EPDM	NBR	VITON	PTFE
E	EXCELLENT																														
G	GOOD																														
P	POOR																														
N	NOT RECOMMENDED																														
--NO INFORMATION AVAILABLE																															
E	EXCELLENT																														
G	GOOD																														
P	POOR																														
N	NOT RECOMMENDED																														
--NO INFORMATION AVAILABLE																															
Potassium Iodide 70%	E	E	—	—	E	Suds	—	E	G	—	E																				
Potassium Nitrate 80%	—	E	G	G	E	Sugarbeet Liquor	—	—	—	G	E																				
Potassium Nitrate 1-5%	—	E	G	G	E	Sulphuric Acid 10-50%	P	E	P	E	E																				
Potassium Oxalate 20%	—	—	—	—	E	Sulphuric Acid 60-70%	P	E	N	E	E																				
Potassium Permanganate	—	E	N	P	E	Sulphuric Acid 80-100%	N	—	N	E	E																				
Potassium Phosphate	—	—	E	E	E	Sulphurous Acid	P	—	N	G	E																				
Potassium Sulphate 10%	E	E	G	G	E	Sulphur 20°C	—	—	N	N	E																				
Potassium Sulphite	—	G	P	—	E	Sulphur Chloride	—	—	N	G	E																				
Potassium Sulphite	—	—	—	N	E	Swimming pool Water	—	E	G	—	E																				
Propane	E	E	G	E	E	Tannic Acid	E	—	N	P	E																				
Propanol	—	—	G	G	E	Tar	E	N	N	G	E																				
Propylene Oxide	—	—	N	—	E	Tartaric Acid	E	—	G	G	E																				
propylene Glycol	—	—	G	G	E	Tetraphosphoric Acid	—	—	—	—	E																				
Pyridine	—	—	N	N	E	Tetrachydrofuran	—	—	N	N	E																				
Pyrogallic Acid	E	—	P	P	E	Tetraethyl Lead	—	—	N	G	E																				
Resins	—	—	—	G	E	Thionyl Chloride	—	—	N	N	E																				
Salicylic Acid	E	—	N	G	E	Toluene	E	N	N	G	E																				
Salt Water	—	E	G	G	E	Tomato Juice	—	—	G	G	E																				
Sea Water	E	E	G	G	E	Trichloroacetic Acid	—	—	N	G	E																				
Sewage	—	G	G	G	E	Trisodium Phosphate	—	—	G	G	E																				
Sewage	—	—	G	G	E	Tributyl Phosphate 30°C	—	—	N	N	E																				
Silver Nitrate	E	E	G	G	E	Trichloroethylene	—	—	N	E	E																				
Silicone Oil	—	—	G	G	E	Transformer Oil	—	—	G	G	E																				
Sodium Acetate	E	E	—	N	E	Turpentine	E	N	G	G	E																				
Sodium Bicarbonate	E	E	G	G	E	Unleaded Petrol	E	—	G	G	E																				
Sodium Bichromate	—	—	—	G	E	Urea	—	—	N	E	E																				
Sodium Bisulphite	E	E	G	G	E	Various Esters	—	—	—	—	E																				
Sodium Borate	E	—	G	G	E	Various Ethers 40°C	—	—	G	N	E																				
Sodium Bromide	—	—	E	E	E	Various Soaps	—	—	G	G	E																				
Sodium Carbonate	E	—	G	G	E	Various Ketones	—	—	N	N	E																				
Sodium Chlorate	—	E	G	G	E	Vaseline	—	—	P	P	E																				
Sodium Chlorite	—	—	—	—	E	Vegetable Oil	—	—	G	E	E																				
Sodium Chloride	E	E	G	G	E	Vinyl Acetate	—	—	N	G	E																				
Sodium Disulphate	—	—	G	G	E	Wet Chlorine Gas	—	E	N	G	E																				
Sodium Fluoride	—	E	—	—	—	Wet Sulphurized hydrogen	—	E	N	E	E																				
Sodium Hydroxide (Caustic Soda)	—	E	P	—	E	Wet Sulphur Dioxide	E	E	G	N	E																				
Sodium Hypochlorite	E	E	N	G	E	White Liquor	—	E	N	G	E																				
Sodium Hypochlorite	—	E	G	G	E	Wine	—	—	G	G	E																				
Sodium Metaphosphate	—	—	G	G	E	Xylene, Xylol	—	—	N	G	E																				
Sodium Nitrate	E	E	P	N	E	Zinc Chloride	E	E	G	G	E																				
Sodium Nitrite	—	—	—	—	E	Zinc Nitrate	—	—	—	G	E																				
Sodium Perborate 10%	E	—	G	G	E	Zinc Sulphate 30%	—	E	G	G	E																				
Sodium Peroxide 10%	—	E	G	G	E																										
Sodium Phosphate	—	—	G	G	E																										
Sodium Silicate	E	E	G	G	E																										
Sodium Sulphate	E	E	G	G	E																										
Sodium Sulphite 10%	—	E	G	G	E																										
Sodium Sulphide 50%	E	E	G	G	E																										
Sodium Thiosulphate	E	E	G	G	E																										
Soft Water	E	E	E	—	—																										
Spirit Vinegar	N	—	N	G	E																										
Stannic Chloride	—	E	G	G	E																										
Stannous Chloride	—	E	G	G	E																										
Starci	—	G	G	—	E																										
Steam 130°C	N	E	N	N	E																										
Stearic Acid	E	—	G	—	E																										





**ARVEN S.r.l.**

*Via Artigiani n° 10*

*25030 Macclodio - Brescia Italy*

*Tel. +39.030.9973973*

*Fax +39.030.9973975*

*e-mail: [info@arven.it](mailto:info@arven.it)*

**[www.arven.it](http://www.arven.it)**